

L. C. KELLEY.
PEDOMOTOR.

APPLICATION FILED APR. 24, 1917. RENEWED MAY 6, 1919.

1,308,675.

Patented July 1, 1919.

2 SHEETS—SHEET 1.

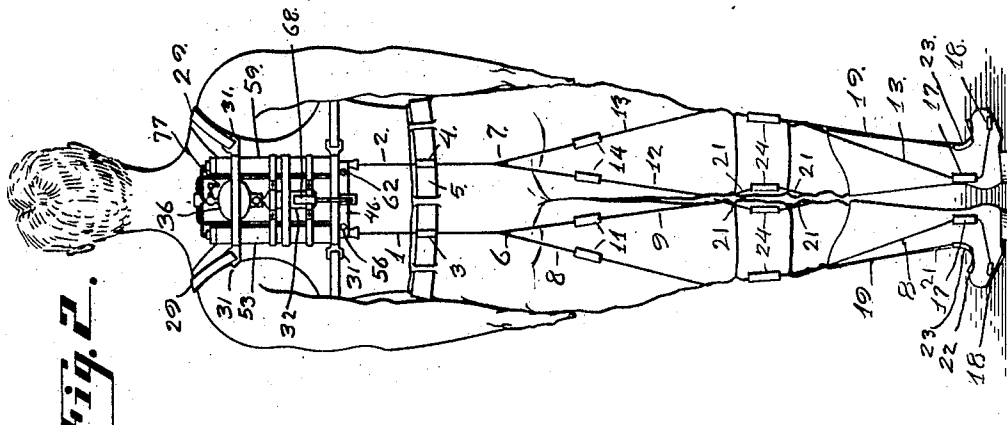

Fig. 2.

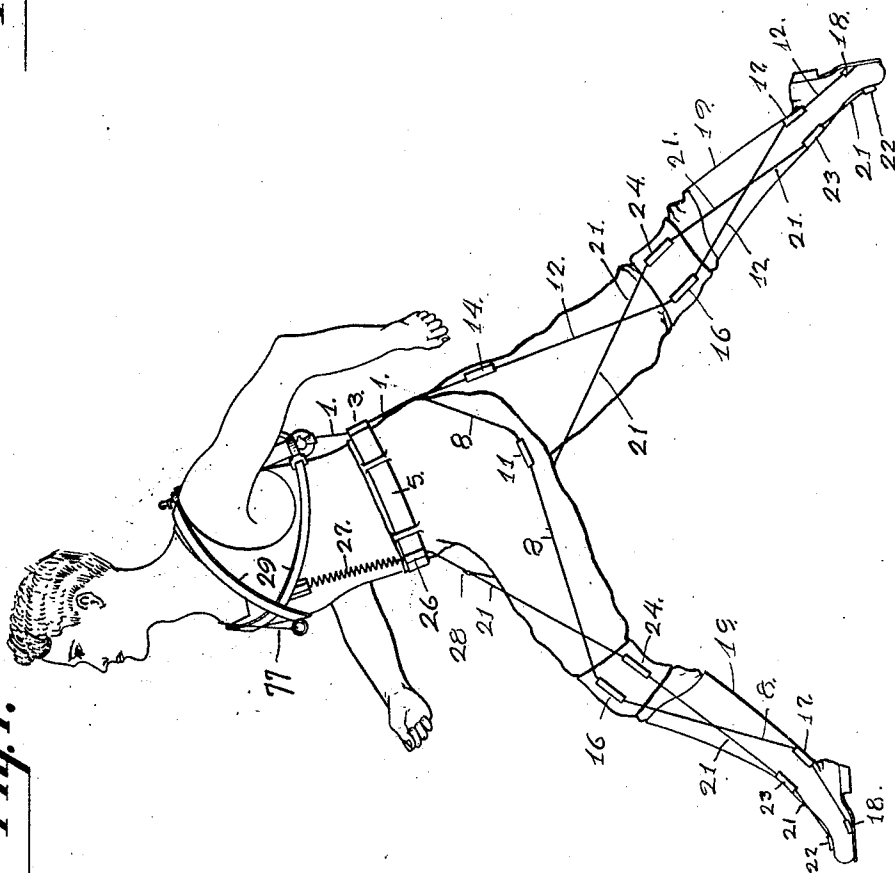

Fig. 1.

Inventor
Leslie C. Kelley
By Arthur L. Slee.
ATTY.

L. C. KELLEY.
PEDOMOTOR.

APPLICATION FILED APR. 24, 1917. RENEWED MAY 6, 1919.

1,308,675.

Patented July 1, 1919.
2 SHEETS—SHEET 2.

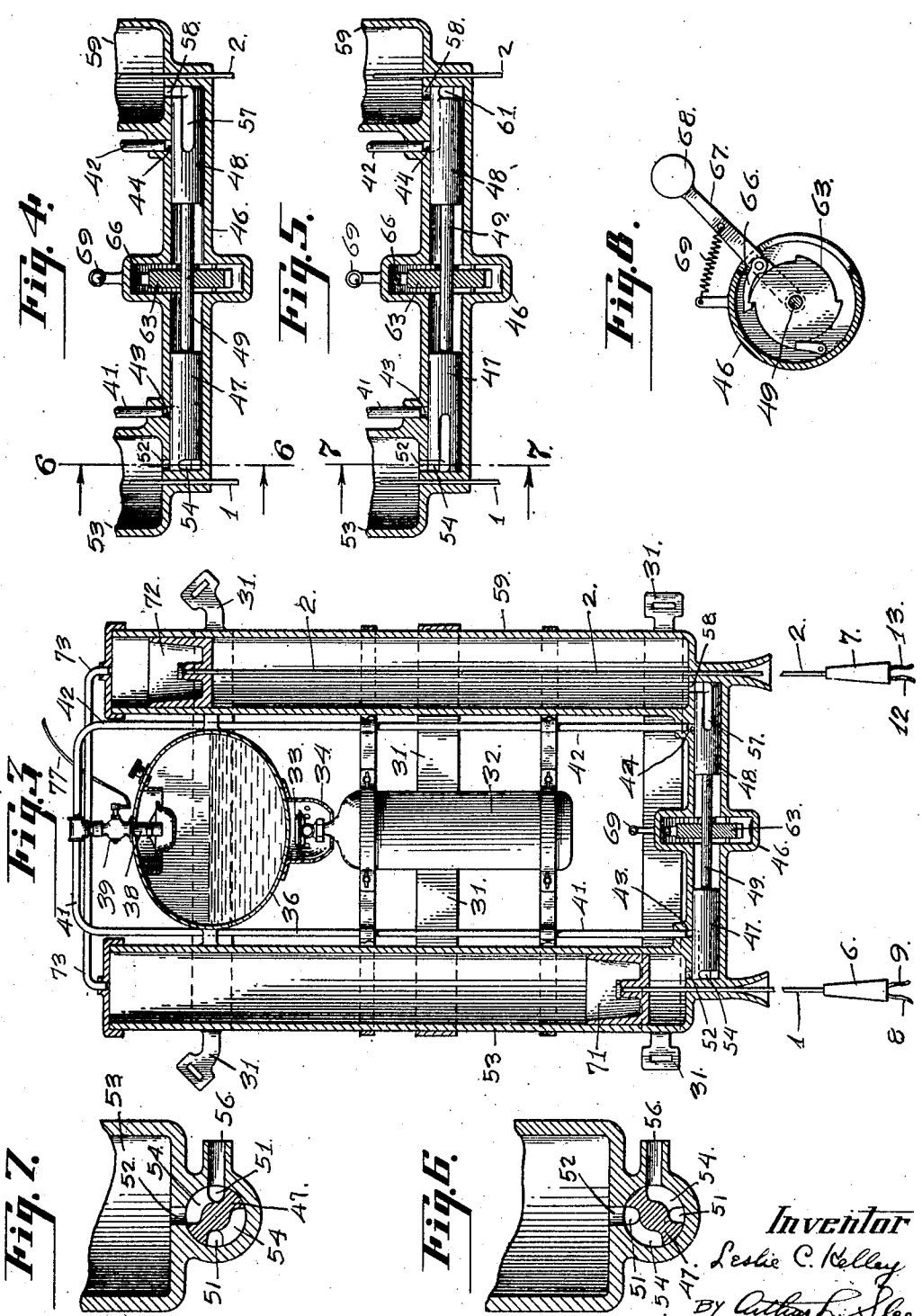

Inventor
Leslie C. Kelley
By Arthur H. Slee,
ATTY

UNITED STATES PATENT OFFICE.

LESLIE C. KELLEY, OF SOUTH SAN FRANCISCO, CALIFORNIA.

PEDOMOTOR.

1,308,675.

Specification of Letters Patent.

Patented July 1, 1919.

Application filed April 24, 1917, Serial No. 164,285. Renewed May 6, 1919. Serial No. 295,107.

To all whom it may concern:

Be it known that I, LESLIE C. KELLEY, a citizen of the United States, residing at South San Francisco, in the county of San Mateo and State of California, have invented a new and useful Improvement in Pedomotors, of which the following is a specification.

My invention relates to pedomotors or power operated running devices to be applied to the human anatomy wherein sets of artificial ligaments operate in conjunction with operating and controlling means therefor; and the objects of my invention are—

First, to provide an improved pedomotor or power operated running device;

Second, to provide improved means for facilitating the operation of pedestrianism or running operation;

Third, to provide a power device adapted to relieve the muscles utilized during the running operation of the anatomy from strain and fatigue;

Fourth, to provide an improved power operated device that shall be adapted to impart greater impetus and thereby increased speed to the person;

Fifth, to provide an improved device of the character described that shall be adapted to operate the principal motor muscles of the legs and to relieve them of the strain occasioned by running thereby eliminating fatigue;

Sixth, to provide an improved device adapted to increase the speed of a runner wherein two sets of artificial ligaments are operated alternately by suitable motive power to produce a running movement.

I accomplish these several objects by means of the device disclosed in the drawings forming a part of the present specification wherein like characters of reference are used to designate similar parts throughout the said specification and drawings, and in which—

Figure 1 is a side elevation of the anatomy disclosed in a running position with my improved device applied thereto;

Fig. 2 is a rear view of the person at rest disclosing the power or operating means;

Fig. 3 is an enlarged vertical sectional view of the motive power and controlling means therefor;

Fig. 4 is a further enlarged sectional view of the controlling valves and concussion op-

erated control of said valves in one position;

Fig. 5 is a view similar to Fig. 4 disclosing the opposite position of the valves;

Fig. 6 is a further enlarged section taken on line 6—6 of Fig. 4;

Fig. 7 is a similar section taken on line 7—7 of Fig. 5, and

Fig. 8 is a transverse sectional view of the approximate central portion of the controlling valves disclosing the valve operating means in elevation.

For purposes of illustration, the hereinafter described device shall be designated as a pedomotor for the reason that the pedal extremities are operated by an artificial motive power, and the various muscles of the anatomy utilized to produce a running movement of the anatomy shall be referred to as the principal motor muscles.

In the running movement as practised by human beings, the power is provided by various muscles which contract and relax to move the legs forward alternately and to bear the weight of the body during such movements. The speed of a runner is mainly in proportion to the strength of his motor muscles.

I propose to provide sets of artificial ligaments corresponding and arranged parallel with the principal motor muscles of the anatomy and motive and controlling means for said ligaments in the following manner:

Referring to the drawings, the numerals 1 and 2 are used to designate two artificial ligaments or wires arranged at the rear of a person and on the left and right sides respectively.

These wires or ligaments 1 and 2, as they shall hereinafter be designated, are slidably held in position by means of sleeves 3 and 4 upon the rear of a suitable belt 5.

The ligaments 1 and 2 are divided to run parallel to and correspond with the principal motor muscles of the anatomy as follows:

The ligament 1 is divided at 6 into two ligaments 8 and 9 which slidably engage sleeves 11, secured to the trousers or other suitable holding apparatus, as disclosed in Figs. 1 and 2 of the drawings and continue down each side of the left leg of the person and after passing through sleeves 16 arranged near the front of the knee pan of the left leg, are again passed on each side of the

leg and to the rear thereof to slidably engage sleeves 17 at the rear of the ankle joint on a boot or shoe 19, the ends of said ligaments 8 and 9 being finally secured to each lower
5 forward side of the foot as at 18.

The ligament 2 is similarly divided as at 7 into two ligaments 12 and 13 which pass through sleeves 14 and similar sleeves arranged as described for the left leg and also
10 secured at their ends to the forward portion of the right foot.

In this manner I have provided two sets of artificial ligaments arranged parallel with and corresponding to the principal
15 motor muscles of the anatomy.

In order to complete the system I have provided two other sets of artificial ligaments arranged to normally bend each knee and bring the foot forward and upward
20 toward the front of the body as when taking a step forward and which may be described as follows:

Two sets of ligaments 21 have their lower ends secured to the toe as at 22 and after
25 passing through sleeves 23 at the front of the ankle joints pass each side of the legs and to the rear thereof to sleeves 24 at the rear of the knees thence back on each side of the legs to common junctions as at 28,
30 through sleeves 26 in the front of the belt 5 and terminate in suitable springs 27 the upper ends of which are secured to a harness 29.

Any suitable motive power may be employed to alternately operate the ligaments
35 1 and 2 to produce a running movement. One type of motive power which I have illustrated, is controlled and operated in the following manner:

The harness 29 has mounted on the rear thereof a suitable frame 31 carrying a gas or other fuel container 32 provided with a burner 33 within a housing 34 on the under
40 side of a suitable boiler 36.

The burner 33 is utilized to transform water within the boiler 36 into steam which is carried through the steam pipe 38, controlled by a suitable valve 39, to two pipes
45 41 and 42 each leading to intake ports 43 and 44 of a suitable control valve mechanism housing designated in general by the numeral 46. The valve mechanism comprises two cylindrical portions 47 and 48
50 connected by means of a stem or reduced portion 49.

The portion 47 is provided with two diametrically opposed longitudinal channels 51 arranged, when in one position to connect the intake port 43 with the port 52 of a
60 cylinder 53, each longitudinal channel 51 having a lateral extension 54 to connect the port 52 with an outlet port 56 in the valve mechanism housing 46, as disclosed in Fig. 7 of the drawings.

Similarly the portion 48 is provided with

two diametrically opposed longitudinal channels 57, arranged when in one position to connect the port 44 with the port 58 of a second cylinder 59, each having diametrically opposed lateral extension channels 61
70 to connect the port 58 with a second outlet port 62 shown in Fig. 2 of the drawings.

The valves 47 and 48 are arranged to be rotated through a one-quarter revolution whereby one cylinder may be alternately
75 connected with the steam boiler 36 and the outlet port 56 while the other cylinder 59 is alternately connected with the outlet port 62 and the boiler 36 respectively, by means of a ratchet 63 connected to the approximate center of the stem 49 and engaged by
80 a pawl 66 pivotally mounted upon an oscillating lever or arm 67 rotatably mounted upon the stem 49 and provided with a weight 68 at the outer end thereof. 85

A suitable spring 69 is provided to normally retain the weighted arm 67 in its upper position.

The weighted arm is arranged to be operated by the concussion occasioned by the
90 running operation when the runner lights with extended foot upon the ground to rotate the valves 47 and 48 through a one-quarter revolution. The said concussion will cause the weight 68 to move the arm 67
95 through one-quarter revolution and thereby cause the pawl 66 to engage and turn the ratchet 63 of the valve stem 49 a similar distance.

Within the cylinders 53 and 59 are slidably mounted pistons 71 and 72 to which
100 are attached the wires or ligaments 1 and 2 respectively.

The upper portions of the cylinders 53 and 59 are closed and connected to each
105 other by means of a suitable connection 73 whereby the upward movement of one piston will operate to lower the other piston.

The valve 39 is provided with a connection or cord 77 which hangs over the shoulder of the wearer whereby the steam pressure may be controlled. 110

The operation is as follows:

The steam control valve 39 being opened to admit pressure to one of the cylinders,
115 say the cylinder 53, the piston 71 therein is moved upward and operates the ligament 1 to correspond with the principal motor muscles of the left leg, the wearer simultaneously lifting and taking a step forward
120 with the right leg. The power transmitted to the ligaments 1, 8 and 9 of the left leg will tend to propel the body or anatomy forward while the ligaments 21 running through the sleeves on the right leg will
125 normally tend to bend that leg at the knee and bring said right leg forward and toward the front part of the upper portion of the body as when taking a step forward.

As the body of the wearer is impelled for- 130

ward as in a leap or running step the concussion occasioned by the impact of the left foot with the ground and the momentum of the weight 68 will cause the arm 67 and pawl 66 thereon to move the ratchet 63 and valves 47 and 48 through a one-quarter revolution which will move the longitudinal channel 51 on the portion 47 away from connection with the intake port 43 and the port 52 of the cylinder 53 and cause the lateral extension 54 to connect said port 52 with the outlet or exhaust port 56 of the valve housing 46 as disclosed in Fig. 7 of the drawings. Simultaneously the longitudinal channel 57 of the valve 48 will be moved to connect the port 44 with the port 58 of the cylinder 59 thereby operating the piston 72 and the ligaments 2, 12 and 13 connected therewith to operate the right leg of the wearer.

Two sets of channels 51 and 57 and lateral extensions 54 and 61 therefor are provided to lessen the required arc through which the weighted arm 67 and the valves 47 and 48 must swing in order to alternate the operation of the cylinders and ligaments attached thereto.

Having thus described my invention what I claim as new and desire to secure by Letters Patent is—

1. A pedomotor comprising two sets of artificial ligaments, each set corresponding with and arranged substantially parallel to the principal motor muscles of each leg and foot of the anatomy; and means for alternately operating each set of ligaments to produce alternately a running movement for each leg and foot.

2. A pedomotor comprising artificial ligaments arranged substantially parallel to and corresponding with the principal motor muscles of the anatomy; means for operating said ligaments to produce a running movement; and controlling means operated by the running movement to control the operating means.

3. A pedomotor comprising two sets of artificial ligaments each set corresponding

with and arranged substantially parallel to the principal motor muscles of each leg of the anatomy; means for operating each set of ligaments independently whereby a running movement may be produced; and controlling means operated by concussions produced by said running movement to alternately operate the separate sets.

4. A pedomotor comprising artificial ligaments corresponding with and arranged substantially parallel to the principal motor muscles of the anatomy; means for operating said ligaments whereby a running movement may be imparted to the motor muscles; means for slidably engaging the ligaments to retain same in operative position; and operating means to operate said ligaments whereby a running movement may be produced.

5. A pedomotor comprising two sets of artificial ligaments corresponding with and arranged substantially parallel to the principal motor muscles of each leg of the human anatomy; means for operating each set of ligaments independently to produce a running movement; and two sets of artificial ligaments arranged to normally draw the leg forward and bend the knee toward the front of the body.

6. A pedomotor comprising a set of artificial ligaments under constant tension tending to bend the knee joint of the user, a set of artificial ligaments and reciprocating parts connected with said ligaments tending to straighten the knee joint against the tension of the first mentioned ligament.

7. A pedomotor comprising a set of artificial ligaments under constant tension tending to bend the knee joint and the ankle joint of the user, a set of artificial ligaments and reciprocating parts connected with said ligaments tending to straighten the knee joint and the ankle joint against the tension of the first mentioned ligament.

In witness whereof I hereunto set my signature.

LESLIE C. KELLEY.