

The ESA Human Arm Exoskeleton for Space Robotics Telepresence

André Schiele, Gianfranco Visentin
European Space Agency (ESA/ESTEC)

Automation & Robotics Section
P.O. Box: 299, 2200 AG Noordwijk, The Netherlands
Andre.Schiele@esa.int, Gianfranco.Visentin@esa.int

Keywords Telepresence, Teleoperation, Exoskeleton, Haptic, Force-Feedback, Anthropomorphic, Controller

Abstract

This Paper describes the design of the ESA Human Arm Exoskeleton, which has been developed to enable force-feedback telemanipulations with redundant robotic arms. It is described, how several shortcomings of previous telemanipulation systems were eradicated, to meet the system requirements for a lightweight, easy wearable and comfortable system.

The patented novelties towards prior arm exoskeletons are enlightened, and the methodology is shown, according to which the system was designed.

The prototype, which has been developed at ESTEC is described in detail, outlining the special features of the design.

1. Introduction

Future Space-missions, will make use of advanced humanoid-like robots.

These multi-DOF robotics are envisaged as crew assistants for Extra-Vehicular Activities [EVA] on the International Space Station or as explorers / first colonizers on planetary surfaces.

The advantage of these systems lays onto their ability to operate in conventional robot programmed modes as well as in telemanipulation and telepresence modes.

Telepresence allows the execution of tasks in highly unstructured environments, where human judgment, real-time motion coordination and handling ability are needed.

In a typical application scenario, a humanoid-like robot maneuvers in a non-live hostile environment, while being remotely controlled from a human operator situated in a safe location.

Such scenarios could be deep-sea robotics applications, offshore and de-mining operations, hazardous and nuclear materials treatment etc.

Thereby, vision, touch and forces are the senses, which, if fed back from these working environments, enable precise perception of the dynamics and

geometrical constraints of operation.

As a result, the human operator feels like being in place of the robot.

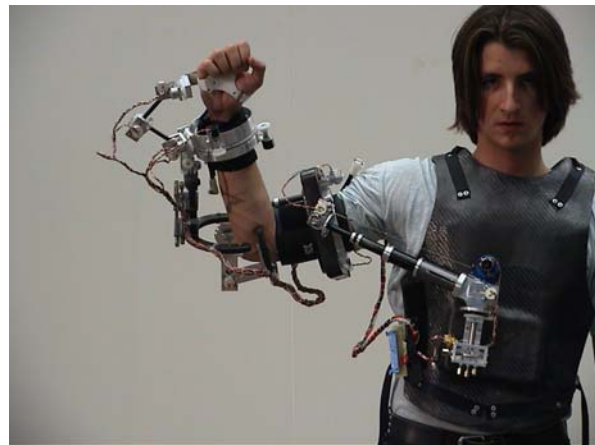

Figure 1: ESA Human arm Exoskeleton as worn during operation (Feedback actuators detached)

Feedback mechanisms are required therefore, to immerse the human operator in the robotic working environment.

In many telerobotics applications, the hand is the only interface to which force and touch feedback is applied, mostly by means of hand exoskeletons or tactile joysticks.

However, for applications where entire humanoid-like robots maneuver in complex, unstructured environments, it is necessary to be aware of the end-effector motion as well as of the arm configuration.

Controlled nullspace motion can be essential to avoid obstacles.

For that, feedback to the operator hands is insufficient, as no constraints, which affect robotic limb-motion can be perceived.

Consequently, to implement whole-body haptic feedback and to command accurate limb-motion, a device, strapped around the operators limbs is needed.

The ESA human arm exoskeleton is such a device.

It has been developed in connection with the “Eurobot” concept, which foresees of a humanoid servicing robot, designed to work on the exterior of the International Space Station, allowing teleoperation from the pressurized inside of the Station.

Using remote tactile feedback to control external robotics, Astronauts can fulfill more complex handling operations as if being packed into their bulky space suits during EVA.

Moreover, avoiding EVA greatly reduces the danger for the crew, saves preparation time, extensive crew training and finally, overall mission costs.

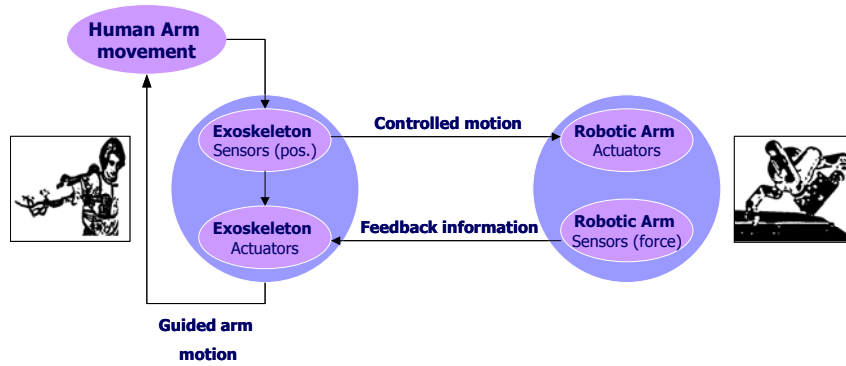

Figure 2: Typical Exoskeleton Control Scenario

- The operator perceives intrinsic or artificially introduced limitations.

Due to its innovative design, the ESA exoskeleton can additionally be used to enable new goods and services outside the Space Domain.

Wherever telepresence technology already exists, this arm exoskeleton enables new applications (Tab. 1).

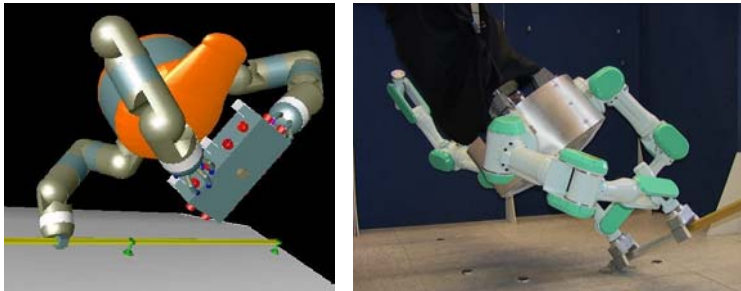

Figure 3: Simulated Eurobot operating on ISS module (left). Eurobot prototype crawling along a structure in ESTEC Robotics Lab. (right)

Especially for unexpected emergencies, the Eurobot concept enables to quickly interact with the outside environment (Fig. 3)

Eurobot will be equipped with 3 arms, kinematically similar to human arms (seven degrees of freedom [7DOF] each, 21DOF in total).

The astronauts will be outfitted with video goggles, force reflecting hand exoskeletons and the ESA arm exoskeleton to feel like being in place of the robot.

During telemanipulations, the robotic arms are slaved to the arm exoskeletons (Fig. 2).

The human arm pose, sensed by the exoskeleton joint-sensors, is fed to a robot controller, which drives the robot arms to the corresponding pose.

Furthermore, the Exoskeleton features actuators connected to its joints, which allow exerting torque on the operator arm such, that:

- The operator perceives forces, which the robot arm experiences in executing the commanded motion.

Medical & Health Sector, Hospitals, Medical Research Centers	Energy Providers, Oil industry
<ul style="list-style-type: none"> • Rehabilitation (passive gymnastics), Strength enhancement • Active Orthosis 	<ul style="list-style-type: none"> • Nuclear, offshore and extreme environment tasks
Entertainment, Movie and Fitness Industry	Hazardous Material Handling and Disposal Industry
<ul style="list-style-type: none"> • Entertaining fitness training (with video-goggles) • Natural animation of virtual characters • Accessory for video-gamming 	<ul style="list-style-type: none"> • Bomb defusing • De-mining operations • Biological decontamination

Table 1: Possible terrestrial applications for the ESA Exoskeleton

2. A brief review about drawbacks of prior Exoskeletons

The main goal during the design of the exoskeleton was, to overcome the known shortcomings of comparable systems:

- Inability to mimic entire range of human arm movements (i.e. shoulder, elbow, wrist)

- Limited adjustability (5th-95th percentile Male population)
- Inability of being wearable systems
- Not permitting long-time operations due to high weight

Why these points are important, is described hereafter:

Prior exoskeleton systems restrict the total possible range of human arm movements, due to the bulkiness of their mechanics.

Huge mechanisms, mostly situated at the top of the shoulder, limit the natural workspace of the human arm.

The bulkiness of the mechanics, results from the need to keep the mechanism joints precisely aligned to the corresponding human arm joints.

These alignments are necessary for all exoskeletons featuring 7DOF, while copying the kinematics structure of the human arm.

Unfortunately, during human arm movement, the physiological joint axes do not remain stable as in a robot.

Taken our multifaceted shoulder-joints as an example, we can say that keeping an attached mechanism accurately aligned to the real joints during shoulder-girdle movements seems unfeasible.

Exoskeleton designers therefore constructed more complex and heavy mechanisms to cope with these problems.

Unluckily, in such systems, misalignments cause a heavily disturbed master-arm movement during feedback operations, which creates quite uncomfortable feelings for the operator.

A further major disadvantage of those exoskeletons is the following:

Aligning such mechanics requires knowing the precise positions of the related joints in the human arm.

This implies determining the human joint axes of each new user, which makes adjustment to different users very difficult and time consuming.

All prior exoskeleton systems are non-wearable systems, which means that they are somewhere fixed outside the human body.

Movements like bowing down, turning around and walking, which might be necessary for operational freedom, are therefore constrained.

Moreover, during operations in reduced-gravity, such as inside the Space Station, a non-wearable force-feedback system creates reaction forces onto the operator body (A force-feedback joystick can already push away the astronaut from the control station).

It is a fact that such impacts evoke major problems

for intuitive handling operations.

Currently, this is solved by strapping the astronaut's limbs and bodies somewhere to the control stations.

3. Design Requirements

Resulting from these disadvantages, the new ESA exoskeleton was designed to meet the following primary requirements:

- Range of human arm motion shall be fully applicable.
- Mechanism shall be easily adjustable for the 5th to 95th percentile of male population.
- The Exoskeleton shall be a wearable system.
- A lightweight design shall keep the total mass below 10kg.
- Actuators for torque-feedback shall be implemented in the wearable part.
- Actuation by the means of cable transmissions to reduce the weight of the arm-segment.

4. Design Methodology

For the design of the exoskeleton, a three-dimensional computer model of the human arm was created first, to allow verifying any proposed mechanism.

Of course, the purpose of the model was not, to exactly mimic the physiological motion of the limbs and bones of the human arm, but to mimic it in terms of resulting movements.

Realistic movements of this model were then recorded as trajectories in Cartesian Space.

Afterwards, during kinematics simulations, robotic models of proposed exoskeleton mechanisms were forced to follow these trajectories while being attached to the model of the arm.

A proposed mechanism was considered feasible, when no collisions between the simulated body segments occurred.

Furthermore, it had to follow the trajectory without reaching into singularities, which disturb smooth motion.

5. Approach

Thus, the human arm was simulated in a computer as a serial link manipulator, whose kinematics was described by Denavit-Hartenberg Parameters.

To determine these parameters, we had to understand, how the joints in the real human arm are articulated, how long the involved body segments are and how these work together during motion of the arm.

However, these human factors are difficult to find and most resources referred to old studies, such as Roebuck, Kroemer and Thomson, 1975 [4] and Clauser et al. [5].

To obtain link length data, anthropometrists dissected cadavers and estimated the static location of joint centers-of-rotation.

The link length was then defined as the length along a segment's main axis from joint to joint.

These resulting values were statistically regressed onto the subject's stature.

Thus, link length values are given as percentiles of the population and as proportions of stature.

The standard error of this data is estimated to be approximately 1.0cm for the bone-length estimates.

The use of these statistical data, allowed us to model the proportions of a human arm and to identify the DH Parameters for the kinematics description (Fig.5).

In terms of link length, our model is based on values, valid for the 5th to 95th percentile of U.S. male population.

A stature of 1.80m was chosen for the beginning.

At a later stage, however, the resulting exoskeleton design was tested with a smaller sized and a bigger sized model of the human arm (representing 5th and 95th percentile respectively).

For the shoulder girdle, five degrees of freedom were needed, two representative for the attachment of the human arm on the sternum (Sterno-clavicular Joint) and three to describe the complex movements of the glenohumeral, acromioclavicular and scapulothoracic joints.

The elbow motion was simulated with two DOF, one for flexion and extension occurring in the humero-ulnar joint, and one for forearm pronation and supination, which takes place in the radio-ulnar joints.

For the wrist, two joints were implemented, to simulate the ellipsoidal joint, whose perpendicular

axes have an offset of about 2cm.

Additionally to creating this kinematics description, the functional anatomy of the upper limb system was studied, to be able to implement the limb-motion as realistic as possible.

Joint mobility values, such as typical joint limits and ranges of movements were taken from Prof. Kapandji [3].

Functional anatomy describes exactly the movements of the articulated limbs, during major arm movements.

Trajectories of such typical movements where then simulated and recorded in Cartesian Space (Fig. 4).

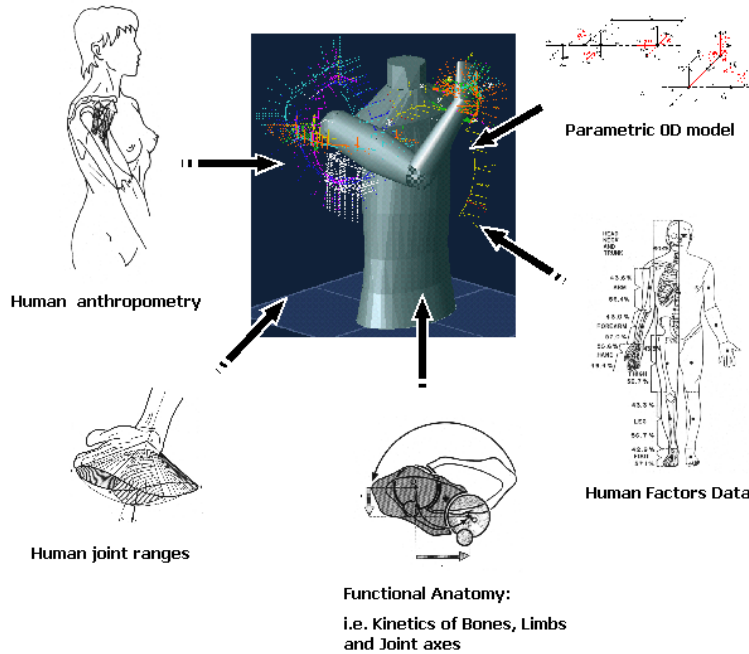
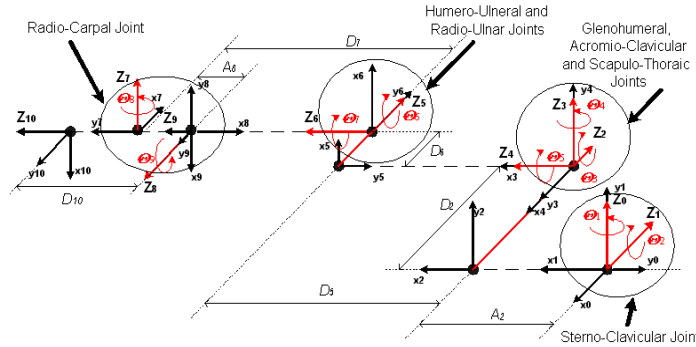

Figure 4 (left): Information needed, to realistically simulate human arm motion. Models and trajectories in centre

Figure 5 (below): Kinematics of Human Arm



Typical simulated movements were:

Shoulder movements:

- Circumduction, Abduction and Retroversion according to "Codeman" Paradoxon, Flexion and Extension, Horizontal Ab/Adduction

Elbow movements:

- Flexion and Extension, Pronation and Supination

Wrist movements:

- Flexion and Extension, Abduction and Adduction

During the subsequent kinematics simulation, the proposed mechanism had to be reconfigured many times, to optimize its performance together with the simulated arm.

Especially shoulder circumduction turned out to be a difficult task for the exoskeleton, not to reach into singularities. Figure 6 describes the final configuration of the accepted mechanism.

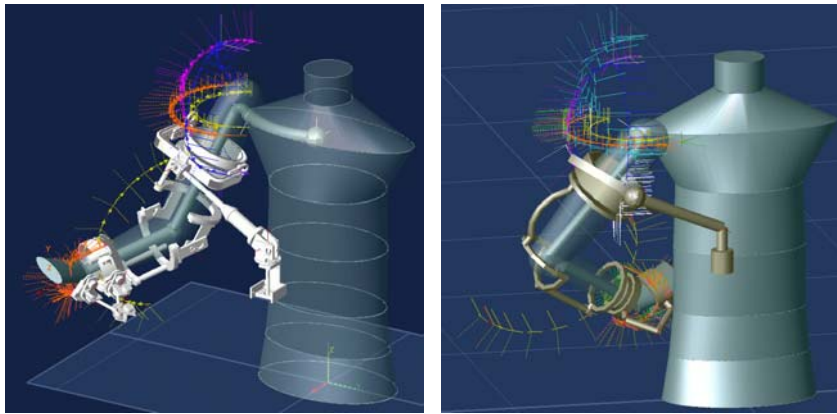

Figure 6: Chosen structure for Exoskeleton. Detailed designed Exoskeleton on opaque torso (left). Preliminary test-model (right).

6. Results from Mechanism Design

The outcome of the simulations was the following:

- The exoskeleton performs best, if its kinematics structure is entirely different from that of the arm.
- The optimal position to fix the base of the exoskeleton is at the chest of the operator
- A prismatic joint enables use of the entire human arm workspace.
- A spherical joint on the attachment of the mechanism on the upper-arm prevents driving into dead-lock positions during long movements.
- Three parallel kinematics for the shoulder, elbow and the wrist, are the optimum solution for combined man-machine motion.
- If the three parallel kinematics are not adjusted to the human joints, the mechanism still works fine.

7. Description of the Prototype

The ESA arm exoskeleton is fixed on a carbon-fiber chest plate, which resembles half an armor top. The plate is secured to the human chest by straps (Fig.1).

The carbon-fiber plate serves as structural base for the chain of joints that articulate the sleeve. It provides a stiff reference for the exoskeleton's base.

Most of the mechanical parts are machined aluminum parts, whereas the large structural parts to enclose the operator's arm were built of carbon-fiber reinforced plastics.

This reduced weight while keeping stiffness of the overall structure.

To reduce friction, we equipped every exoskeleton joint with ball bearings.

Consequently, the mechanism pursues every human arm motion unobtrusively.

A back plate, which holds the feedback motors, is currently in the design phase.

The joints can be actuated from that motors by a series of flexible tendons.

Altogether the exoskeleton master-arm comprises 16 degrees of freedom.

Every axis is equipped with an angular sensor to gain information about the joint-angles.

The joints are grouped in three major sub-assemblies:

- The shoulder-assembly (6 DOF)
- The elbow-assembly (4 DOF)
- The wrist-assembly (6 DOF).

Whereas these three assemblies build up one single mechanism, they will be separately explained in more detail (Fig.7).

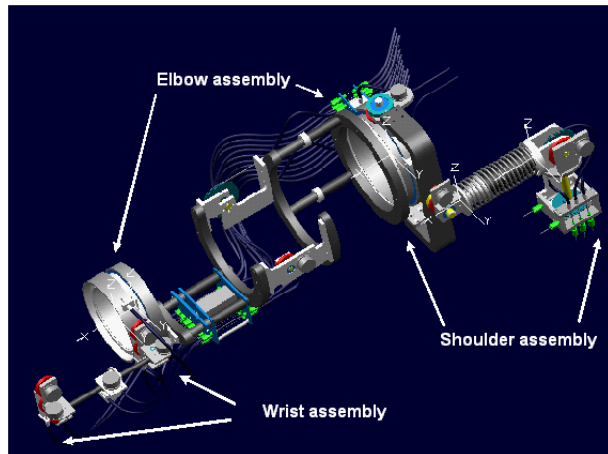

Figure 7: The three Exoskeleton assemblies

The shoulder assembly

The shoulder assembly includes six axes, five revolute and one prismatic.

Thanks to the arrangement of the joints, the movement of the exoskeleton does not limit natural shoulder-girdle movement, neither in extent nor in dexterity.

Figure 8 shows the shoulder assembly as it is attached to an operator body.

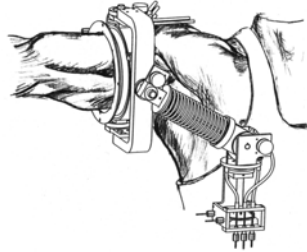

Figure 8: Shoulder assembly attached to human operator (left: Exoskeleton Prototype, right: Artist impression)

Whereas the proximal end is attached to the chest-plate, the distal end of that mechanism is located at the base of the upper-arm, where it is secured by an

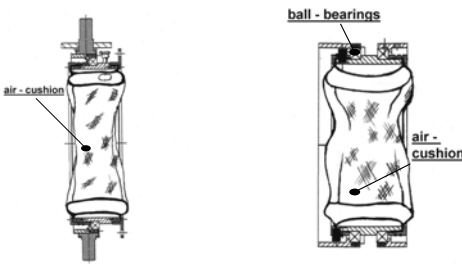

Figure 9: Section-cut of Exoskeleton fixations on arm. (left: upper arm fixation, right: forearm fixation)

inflatable air cushion (Fig. 9).

This cushion, made of silicone rubber can be inflated through the attached squeeze pumps.

When inflated, the ring creates a non-slipping fixation between the human arm and the outer aluminum rings, which constitute the fixations for the exoskeleton mechanical structure.

For applying a feedback torque to the user arm, joints 1 and 2 can be actuated by motors. Activation takes place remotely, by pulling

tendons, which are fixed with pulleys on the joint-axis. The motors will be relocated to a plate, which is attached to the back of the operator.

The prismatic joint consists of a telescopic beam, which is extended by a preload spring.

A tendon, attached to the inside tip of the telescopic beam and running through it, forces the telescope to collapse by counteracting the extension spring.

Joints 4 and 5 are purely passive joints.

Joint 6 is actuated and is used to enforce the roll rotation of the upper-arm.

Joints 4, 5 and 6 have their axis intersecting in a point, which allows them to act as a single spherical joint articulation at the distal end of the first assembly (Fig. 10).

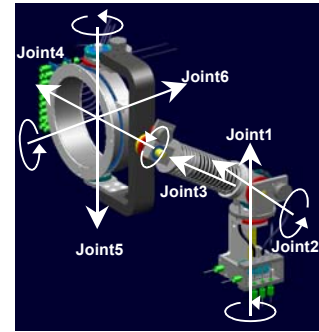

Figure 10: Front-view on Shoulder-assembly (3D CATIA Model)

The elbow assembly

The elbow-assembly comprises 4 axes and is attached to the distal end of the shoulder assembly (Fig.11)

Starting from the left, two twin adjustable-length telescope beams provide the means to adapt the length of the exoskeleton to the human upper arm.

The length can be regulated by adjusting two screws, one at each beam.

For the entire exoskeleton, no other adjustment is necessary.

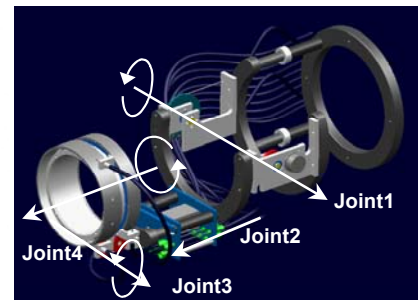
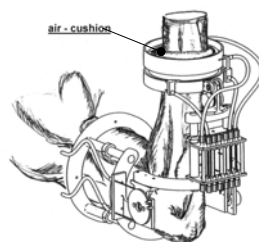

Figure 11: Elbow assembly. (left: Artist impression of attached assembly, right: 3D CATIA Model showing the Joint axes)

The first joint is a tendon-actuated revolute joint, which feeds back torques to enforce flexion or extension in the human elbow joint.

The second joint (prismatic), and the third joint (revolute) are passive joints and compensate alignment errors.

These passive joints guarantee accurate sensing and undisturbed force-reflection to the elbow.

The distal end of the elbow assembly contains another inflatable air cushion to attach the exoskeleton on the forearm and comprises another revolute joint (Fig. 9 (left)).

The actuation of the 4th joint enforces forearm pronation and supination.

The wrist assembly

The third part of the exoskeleton features 6 axes.

The proximal end of the assembly is also attached to the forearm-air-cushion and the distal end is fixed on a hard-plastic glove.

Once more, some passive joints have been integrated.

In the top-view, three revolute joints 3, 4 and 5 can be seen (Fig. 12 (right)).

Whereas joints 3 and 5 are purely passive, two tendons actuate joint 4.

This enforces wrist abduction and adduction, causing passive movements in joints 3 and 5.

If the tendons actuate joint 4 clockwise, abduction is enforced.

As soon as the tendons drive joint 4 counter-clockwise, adduction is enforced.

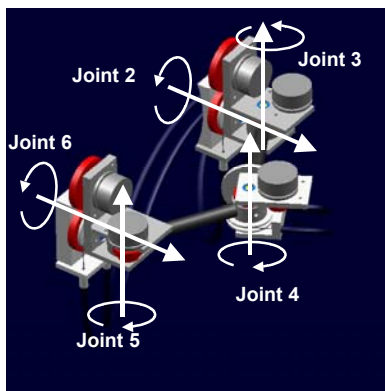

Figure 12: Wrist assembly. (left: 3D CATIA Model showing the Joint axes, right: Artist impression of attached assembly)

To understand how torque is exerted to wrist flexion and extension, the isometric-view will be helpful (Fig. 12 (right)).

Joints 2 and 6 are both tendon actuated.

If, both joints turn clockwise, the attached exoskeleton links will drive the human wrist upwards, (conversely counter-clockwise rotation drive downwards) or, if both joints are blocked, no wrist flexion can occur.

As the human wrist is not spherical but an ellipsoid joint (two main axes not striking trough one common point), joint 1 needed to be introduced, to compensate the eccentricity of any combined adduction and flexion movements.

The tendon actuation

Actuation torque is remotely transmitted using cable tendons, routed along the exoskeleton structure from the motors, sitting on the back chest-plate, to each active joint.

For the tendons 7x19 multi stranded 1mm diameter wire cable was selected to minimize bending friction and bear loads up to 50Nm.

To effectively transmit torques with a cable tendon transmission, the cables must be preloaded to half of their working load, due to elasticity.

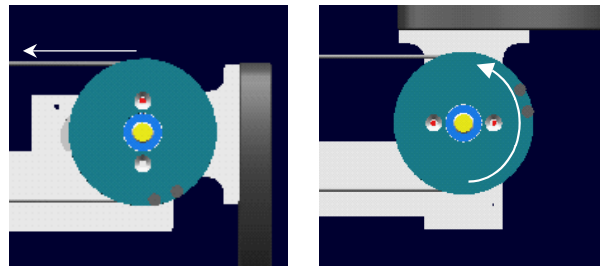
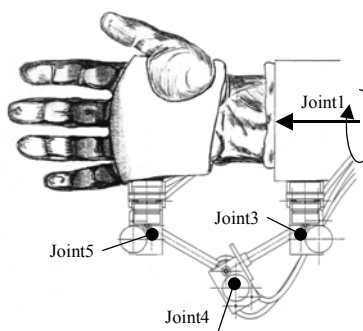

Figure 13: Joint actuation

All rotational joints have two tendons each, allowing clockwise and counter-clockwise motions (Fig. 13).

The tendons are routed on the exoskeleton through flat-wire spiral sleeves. The guidance-length of these flat wire spirals can be changed with respect to the tendon length, which preloads the tendons running through.



8. Novelties

A major innovation of the ESA exoskeleton stands in the approach to kinematics.

There is no attempt to imitate the human shoulder, elbow or wrist kinematics.

In contrary, an alternative kinematics chain offering the same freedom of motion is bridged over the human joints.

This chain and the human joints form a closed kinematics loop that:

- For the shoulder begins at the sternum, bridges over the claviscapular and glenohumeral joints and ends in the middle of the humerus bone.
- For the elbow begins at the middle of the humerus bone and ends at the middle of the forearm.
- For the wrist starts at the middle of the forearm and ends in the middle of the palm.

Even though the kinematics of the exoskeleton and the human arm are different, any posture of the human joints (i.e. shoulder-girdle, elbow, ellipsoid wrist joint) can be univocally determined by the corresponding posture of the exoskeleton.

Advantages of this approach are:

- The weight of the system is not carried by the arm but by the thorax (hence the spine).
- The complete range of human shoulder, elbow and wrist motion is still possible, when the exoskeleton is worn.
- The exoskeleton joints are simpler and smaller.
- No major alignment between the human joints and any of the exoskeleton joints is needed.
- The Exoskeleton is a wearable system.

The second innovation is the use of cable tendon transmissions, guided through flat-wire spiral sleeves.

This special use of tendon transmission allows relocating the drive units on the back plate of the exoskeleton where their weight is carried by the thorax.

The result is an extremely light arm that can be driven by smaller drives.

The third improvement results from the combination of kinematics as well as the use of adjustable limbs and inflatable arm collars.

This makes it possible to adapt the exoskeleton to any human subject (5th - 95th percentile male

population) by adjusting the length of only one Exoskeleton limb.

Else, no alignments are required.

The first prototype of the exoskeleton, however, does not allow such diversity of users.

The reason is the fixation on the upper-arm, which requires inserting the human arm in a large-diameter thin-section ball bearing.

For very muscular or fat people, the diameter of 127mm is too little to insert their arm.

Thus, for the moment, not everybody can use the exoskeleton.

9. Future Work

At the moment we work on the control between Eurobot and the Exoskeleton.

At this stage we try to telemanipulate one arm of Eurobot with the ESA Exoskeleton.

Furthermore, currently the design of the back-plate carrying the force-feedback actuator is in its first stage.

In the near future, the fixation on the upper arm will be re-worked, to allow the exoskeleton being worn by people with larger upper arm diameters.

Also the telescopic mechanism will be re-designed, to provide higher torsion stiffness.

A hand-exoskeleton will be integrated into the system, to allow telepresence operations of the entire arm and the hand.

Reference:

[1] A. Schiele, "Development of a Human Arm Exoskeleton for Space Robotics Telepresence: From Biomechanics to Mechanism Design", ESA Final Report, EWP – 2161, November 2001

[2] D.B. Chaffin Ph.D., G.A. Andersson MD, "Occupational Biomechanics", Wiley-Interscience, NY 1984

[3] I.A. Kapandji, "Funktionelle Anatomie der Gelenke", Band 1, "obere Extremität", 2nd edition, Ferdinand Enke Verlag, Stuttgart, 1992

[4] Roebuck, Kroemer, Thomson, "Engineering Anthropometry Methods", 1975

[5] Clauser, Churchill, Mc Conville, Laubach, and White, "Anthropomorphic surveys done for the U.S. Army"