

# Ambulatory KAFOs: A Biomechanical Engineering Perspective

**Kenton R. Kaufman, PhD, PE**

**Steven E. Irby, MS**

Individuals with proximal weakness of the lower extremity are often prescribed knee-ankle-foot orthoses (KAFOs), also known as long-leg braces, to compensate for severe weakness of the lower limb muscles. More than 1.5 million people in the United States have partial or complete paralysis of the extremities.<sup>1</sup> Prevalence of paralysis increases with age ( Figure 1 ), and it is not surprising that the mobility of individuals with neuromuscular disorders is one of the most common and complicated issues treated by rehabilitation professionals. Many of these individuals require assistive technology (AT) in the form of an orthosis to enhance mobility ( Table 1 ).<sup>2</sup> It is important to note that although there is a greater need for assistive technology as age increases ( Figure 1 ), the use of AT actually decreases with age ( Figure 2 ).<sup>3</sup> This usage with age is due, in part, to consumer rejection of KAFO designs.

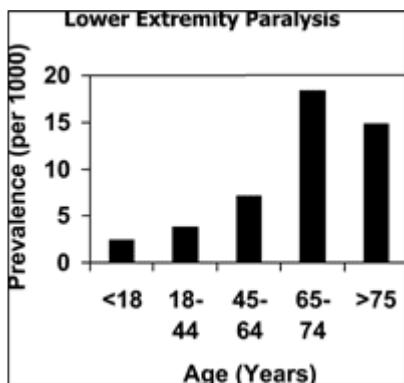

Figure 1. Prevalence of lower extremity paralysis in the United States.<sup>1</sup>

Device	Population
Knee orthosis	989,000
Leg orthosis	596,000
Foot orthosis	282,000
Leg or foot prosthesis	173,000
<b>Total</b>	<b>2,040,000</b>

Source.<sup>2</sup>

Table 1. US population requirements for assistive technology for the lower extremity, 1994

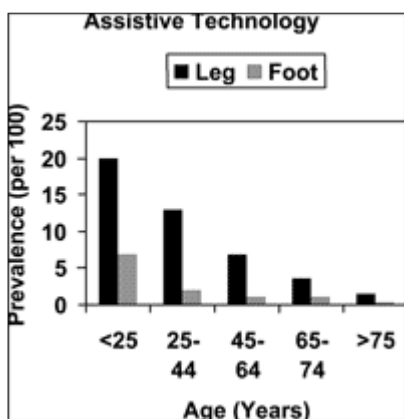

Figure 2. Use of assisted device technology in the United States.<sup>3</sup>

Typically, KAFOs are extremely simple mechanically and often have few moving parts. This simplicity is accompanied by ease of donning and durability but leaves functional abilities only partially improved. Historically, KAFOs have locked the knee joint, providing stance phase stability while preventing knee motion during swing. Alternatively, KAFOs with an eccentric knee joint allow knee motion during swing but provide limited stability during stance. Either design results in inefficient gait. More recently, stance control orthoses have emerged on the market. These devices use a knee joint that is mechanically stable during the stance phase but releases for swing phase. The resulting gait is much smoother than the gait with a traditional KAFO where the knee remains locked throughout the entire gait cycle. Continued engineering development and creativity will be required for evolution of these designs into viable components for use by patients with knee instability during stance.

## HISTORICAL PERSPECTIVE

In the past, two types of KAFOs were generally prescribed: eccentric (or free) knee joint and locked (or fixed) knee joint. Eccentric knee orthoses are stable in extension as long as the ground reaction force vector passes anterior to the knee hinge axis. The eccentric hinge

orthosis design provides limited stance stability and allows flexion and extension to occur at all times. However, an individual must maintain the force vector anterior to the knee hinge axis during stance for stability. The eccentric knee joint provides free knee mobility during the swing phase of gait. In contrast, maximum stability is achieved in the locked KAFO. A locked knee joint orthosis keeps the knee joint straight at all times except when disengaged manually to permit knee flexion during sitting. This design allows stance phase stability but does not allow any swing phase knee mobility.

Unfortunately, KAFOs can be heavy, rigid, and frustrating devices. In practice, people who require KAFOs typically accept them for a very short period after injury or disease, but many soon reject them at rates from 60% to 80%,<sup>4,5</sup> presumably because walking with locked knees demands so much energy. Adding a 1.8 kg (4 lb) weight at the ankle of able-bodied subjects has been shown to increase oxygen cost (ml  $O_2$ /kg m) in level walking by 20%.<sup>6</sup> Similarly, locking the knee of able-bodied subjects during locomotion increases the oxygen cost by 23%.<sup>7</sup> Moreover, walking with bilateral KAFOs is more inefficient than wheelchair propulsion in individuals with paraplegia who require two KAFOs to walk, even for those who customarily use orthoses for locomotion.<sup>8</sup> These data clearly demonstrate that walking with KAFOs is much less energy efficient than typical walking, whereas wheelchair propulsion approximates the energy required for typical walking. So, it is not surprising that individuals delay or refuse to use KAFOs and select wheelchair propulsion as a primary mode of locomotion when walking with bilateral KAFOs requires far more energy.

Addition of hip joint and/or torso control creates other strata of orthoses. These would include the hip-knee-anklefoot orthoses (HKAFO), the torso-hip-knee-ankle orthoses that include torso support, and the family of reciprocating gait orthoses (RGO). These are generally used to manage paralysis, but some may also be used in the rehabilitation setting. The knee joint has historically been locked in full extension for maximum stability with these orthoses as well.

## CURRENT DEVELOPMENTS

Recently, KAFO design has been advanced by the introduction of mechanisms that provide stance phase control and swing phase freedom.<sup>9</sup> These are referred to as stance control orthoses (SCO). Stance phase control means that knee joint flexion is restricted during stance, the weight bearing phase of the gait cycle. These mechanisms are designed to release the knee, allowing both flexion and extension during swing, the non-weight-bearing phase of the gait cycle. The intent is to allow a more normal, energy-efficient, and cosmetically appealing gait. The potential benefits of a knee brace design that allows swing phase motion while providing stance phase knee joint control have been recognized since 1918 and are gaining attention as designs are brought to the commercial market for clinical application.<sup>9,10</sup> Over 20 device patents have been filed in the United States and internationally that purport to have solved this problem. In general, studies of SCOs have reported improved gait symmetry and reduced energy consumption when using an SCO.<sup>11-19</sup> However, all of these studies have been performed on a limited number of subjects. Only one report demonstrating benefits on greater than 20 subjects currently exists in the literature.<sup>20</sup>

Functional electrical stimulation (FES) has been combined with orthotics to improve paraplegic gait.<sup>21-26</sup> The simplest form of these hybrid systems relies on the intrinsic musculature to provide motive power while the orthosis is used to guide the limbs and lock the joints appropriately. Muscles are electrically activated via external or indwelling electrodes. Reports including up to 70 patients show promise,<sup>27,28</sup> but the technology has not been widely adopted to date. Development work is ongoing in the areas of patient testing and computer simulation.<sup>21,29</sup> Clearly, additional research is needed to guide the development, document the efficacy, and define the appropriate applications for these new technologies.

## MATERIALS

A wide variety of materials are used for orthotic applications. Traditionally, steel was used for the upright and leather to line the cuffs. These materials are still used in some instances, but newer materials open up possibilities for better design, stronger support, increased durability, and improved cosmesis. All materials considered for new applications should meet certain criteria that determine their suitability for use (Table 2).<sup>30</sup> Strength is the most important criteria for a lower extremity orthosis. Orthoses must have sufficient strength to control the stresses imposed by the wearer. Stress will result in strain, which is the change in shape of the material. The amount of stress that must be applied to a material to cause strain is known as stiffness. Stiffness requirements may vary. In some applications, it is desirable to have a very stiff and rigid material that allows virtually no deflection when loaded. In other applications, however, it is desirable for the materials to conform to the body shape and absorb or store elastic energy that can be returned during the gait cycle. Material failure can result from two causes. First, excessive strain can deform the orthosis to the point where it permanently changes shape or breaks completely. If designed appropriately, the material will be able to withstand millions of repeated loading cycles. However, fatigue resistance is required in this situation. Currently, no information exists regarding the number of cycles orthotic devices should undergo to avoid fatigue failure. Consequently, the metal or plastic may eventually fail and necessitate frequent repairs. Density, or weight per unit volume, is also important in selecting a material. The goal is to have the orthosis be as light as possible to minimize the energy required to move with the orthosis. Corrosion resistance is required to withstand use in harsh field environments. Any material selected should be readily shaped to conform to the body segment. Finally, any material utilized should be readily available at reasonable costs.

Strength	Maximum external load that can be withstood
Stiffness	Stress/strain or force-to-displacement ratio
Durability (fatigue resistance)	Ability to withstand repeated loading
Density	Weight per unit volume
Corrosion resistance	Resistance to chemical degradation
Ease of fabrication	Equipment and techniques needed to shape it

Source.<sup>30</sup>

Table 2. Important characteristics of orthotics materials

## KAFO UPRIGHTS

Traditionally, metals have been commonly used for the uprights, including steel, aluminum, and alloys of titanium and magnesium. Steel is most commonly used. It has the advantages of low cost, ready availability, and relative ease of fabrication. It is strong, rigid, and fatigue resistant. However, it is also heavy. Aluminum is a much lighter material than steel with a high strength-to-weight ratio. The primary disadvantage of aluminum is that it is relatively low in fatigue resistance. Titanium and magnesium are strong, lightweight, and have good corrosion resistance. However, they are more expensive and are typically used in high-demand situations. Manufacturers have adopted a classification system for prosthetic components that considers the patient weight and functional demands ( Figure 3 ). This guide makes it easy for the practitioner to select the components that will support the patient's weight and functional activity level. In this way, the lightest weight and least expensive components may be selected. A similar type of classification system should be developed for orthotic components.

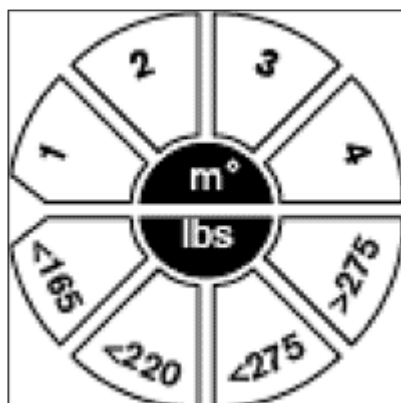

Figure 3. Otto Bock Classification Matrix (copyright owned by and photo reprinted with permission of Otto Bock Health Care).

## KAFO CUFFS

Materials for fabrication of cuffs have changed. Steel or aluminum uprights with leather cuffs have been traditional materials. However, metal uprights with limb-enclosing cuffs covered with leather and fastened with buckles are becoming a design of the past. Greater strength and stiffness can be developed with newer plastics that are lighter and more cosmetically appealing than metal orthoses. Commonly used materials include polypropylene (homopolymer and copolymer) and polyethylene (low density, high density, high molecular weight, and ultra-high molecular weight). Other than the application of modern plastics to orthotic designs, there have been no substantive changes to traditional long leg braces for decades.<sup>31</sup>

## JOINING TECHNOLOGY

As noted above, the types of materials most commonly used in current orthotic practice include metal, leather, and plastic. These materials need to be joined together to create a functional KAFO. However, little attention is paid to the methods for joining technology. Typically, rivets or screws are used. The fastening materials are made from aluminum, copper, brass, or steel. Because the softer aluminum, copper, and brass rivets must be larger than steel rivets to achieve the same strength, larger holes are needed to accommodate the softer rivets. In the orthoses, the larger holes in respect to the dimension of the metal uprights weaken the material. Although recommendations have been made for this application,<sup>32</sup> very seldom is attention paid to the spacing of the fastening component or the edge distance. Conversely, the larger holes in softer plastic cuff material help distribute the load over a wider area making a better metal-plastic joint. Basic knowledge of the material properties used in orthotics is essential for achieving a robust design with minimal fabrication costs. Selection of the correct material for a given design depends on the engineering properties of the materials along with the intended use. A good understanding of the stresses that will be encountered during daily use is necessary to achieve an orthotic design that is safe, durable, and meets the user's requirements.

## BIOMECHANICS

All orthoses apply forces to the body. The purpose of a KAFO is usually to provide knee stability during stance. In doing so, the orthosis applies forces to control knee motion. The engineering design must carefully consider the resultant forces throughout the device and provide componentry with sufficient strength to withstand these forces. The amount of force and the area of the body subjected to the force also influence the comfort of the orthosis.

## ALIGNMENT OF JOINT AXES

Careful attention must be given to alignment of joint axes. The anatomical joint axis and the mechanical joint axis of the orthosis must be coincident. If the axes do not coincide, undesirable forces are generated as the joint goes through its range of motion. If the axes of the knee and the brace are parallel but displaced, binding forces are created in the plane of movement.<sup>33</sup> If the knee axes are not parallel but intersecting, side loads and twisting moments will be applied to the leg ( Figure 4 ). These forces from malalignment must be transmitted through both the orthosis hardware and the patient-orthosis interface. The response to these forces can influence orthosis performance and the length of useful life in the field.

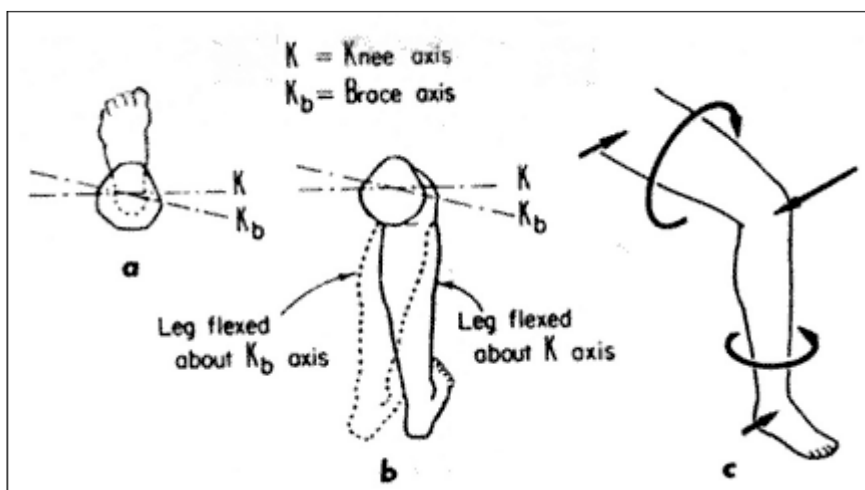

Figure 4. Effect of rotating brace axis internally to knee axis. A, relation of axes (looking down from top, knee extended); B, leg position when flexed about skeletal and brace axes, respectively (looking down from top); C, side loads and resulting twisting moments applied to leg as a free body in equilibrium.<sup>33</sup>

### FORCES IN ORTHOTIC DESIGN

Most orthotic designs use a balanced parallel force system to control joint motion. The forces are distributed in either a 3-point or 4-point control system ( Figure 5 ).<sup>34</sup> The orthosis is designed to apply force of a particular magnitude at a specific point or place on the limb segment. The forces may be substantial. If sustained over long periods of time, these forces may lead to tissue deformation and breakdown. Moreover, as the knee moves, the mechanics of the brace change.<sup>33</sup> When the knee is extended, a 3-point pressure control system is in effect ( Figure 6 ). However, with flexion, additional torques are applied to the knee brace. These torques need to be absorbed either by the brace componentry or the brace/patient interface. If the torques are not balanced, the brace will rotate, causing malalignment and malfunction. The magnitude of these forces is unknown and not considered in existing standards. The resulting shear forces and torques will have an impact on KAFO function. Further, the support structures must be taken into account to maximize patient comfort and to minimize the long-term consequences of the shearing forces on joint and soft tissue integrity.

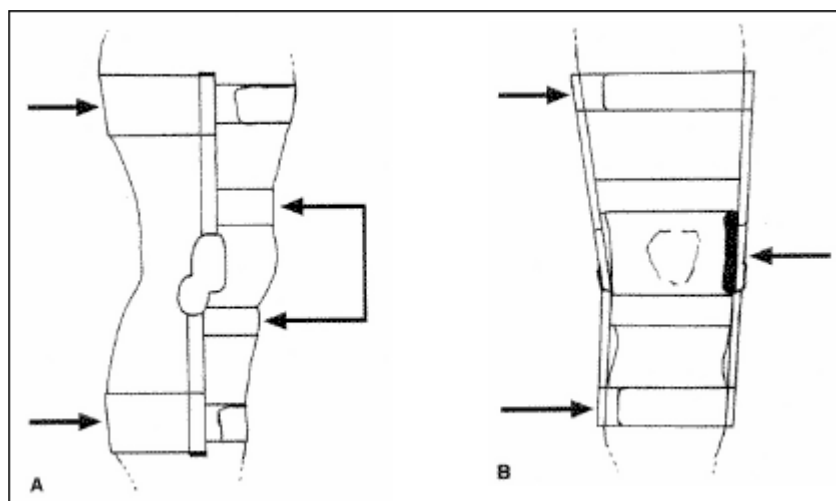

Figure 5. A, For a patient with instability of the knee, this four-point control system is designed to control sagittal plane translatory motion between the tibia and femur. Distributing the counterforce on either side of the knee joint axis reduces shearing forces at the knee joint while simultaneously controlling knee flexion. B, The same orthosis controls valgus at the knee in the frontal plane using a three-point control system. Note the enlarged medial pad that is used to distribute  $F_c$  comfortably over a large area. Rotation of the tibia in the transverse plane cannot be controlled effectively by this design. To provide complete control of tibial rotation, the orthosis would have to incorporate the foot and ankle as well.<sup>34</sup> Reprinted from *Orthotics & Prosthetics in Rehabilitation*, Lusardi MM, "Principles of Orthotic Design," pp. 77-87, Copyright (2000), with permission from Elsevier.

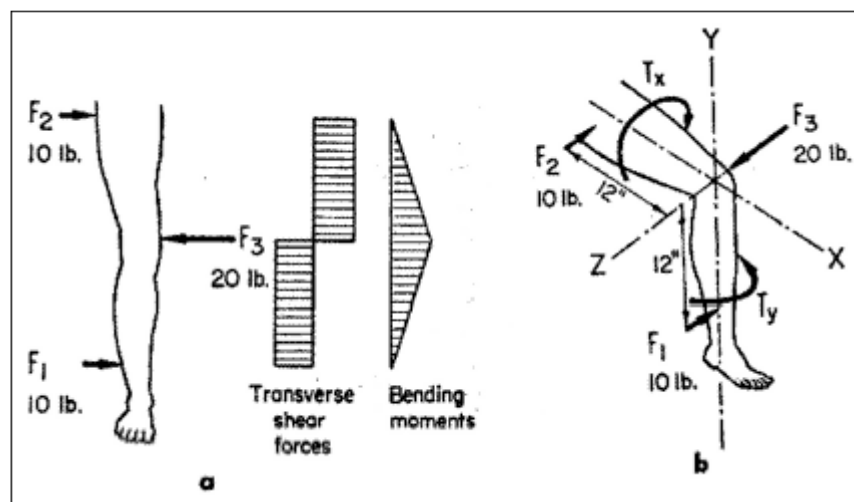

Figure 6. Beam loading produced by brace for correction of genu valgum. A, leg loaded as a straight beam; B, leg loaded as a beam with a 90 degree bend.<sup>33</sup>

## JOINT MOTION

Orthosis users may not be able to attain a full or "normal" range of motion because of bone or soft tissue limitations. As a result patients will load the orthoses over a wide range of joint angles. As an example, Irby et al.<sup>20</sup> report stance phase knee joint measurements ranging from -9 to 35 degrees during SCO testing ( Figure 7 ). In this clinical trial, two subjects had knee flexions of 35 degrees during stance phase due to knee flexion contractures. The increased knee flexion results in increased loading on the KAFO hardware.

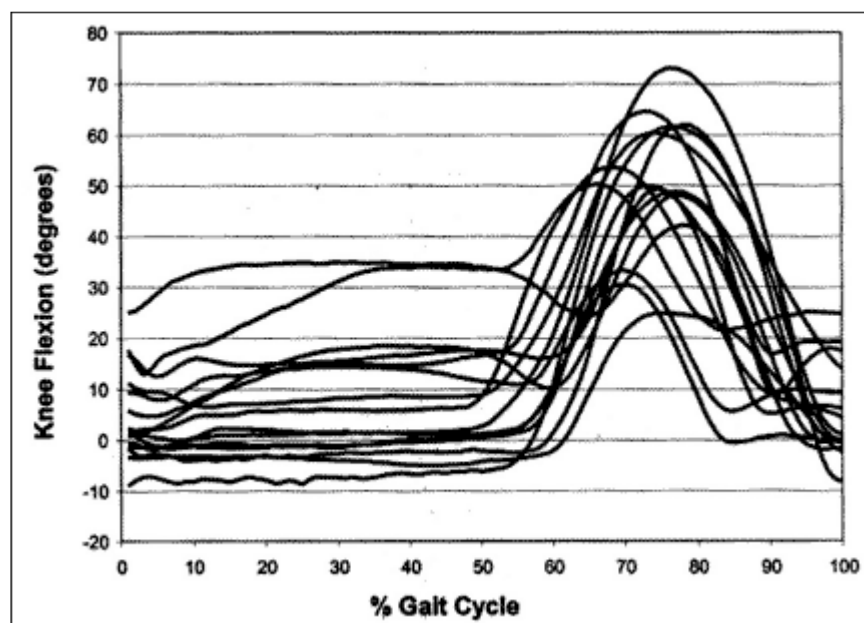

Figure 7. Knee flexion for SCO users. The knee flexion during stance varies by user. Some individuals walked in recurvatum, whereas other subjects had knee flexion contractures that necessitated knee flexion of up to 35 degrees during stance. All users demonstrated swing phase mobility.<sup>20</sup>

## FORCES IN KAFOS

As stated above, there are no standards for the structural requirements of KAFOs. Functional requirements will depend on body weight and the knee flexion angle. Simple extrapolation of knee joint demand based on body weight is misleading because moments at the knee are also a function of joint position and vary with gait characteristics. Designers must consider both the basic structural capabilities of the componentry and the functional performance desired. A clinical field trial performed by Irby and colleagues<sup>20</sup> highlights the demands placed on the KAFO structure. In that field trial, the average age for the 21 research participants was  $53 \pm 15$  years (range, 11 to 76 years). Body weight average was  $83.9 \pm 20$  kg (range, 50.8 to 127 kg). Body mass indices (BMI) ranged from 19 to 40, with an average of  $29 \pm 6$ . According to the Centers for Disease Control,<sup>35</sup> this group consisted of five normal, eight overweight, and eight obese participants. Objective measurements of dynamic knee moments demonstrated a range of demands on the orthosis ( Figure 8 ). The maximum demand in a laboratory setting was 67.3 Nm for an individual weighing 97.5 kg. The second highest knee moment was 47.9 Nm and was generated by an individual whose weight was 113 kg. The heaviest participant weighed 127 kg but walked with a cane, which reduced the joint moment. This load can be compared with the structural capabilities of the uprights commonly used in KAFOs. The common size of uprights is 5 X 19 mm (3/4 X 3/16 inches). These uprights are available in aluminum, stainless steel, or titanium. The theoretical strengths of existing uprights are shown in Table 3 . The demand of this single user reached 80% of the maximum bending moment that a single aluminum upright could sustain. However, no standards exist to specify the loads KAFOs should sustain.

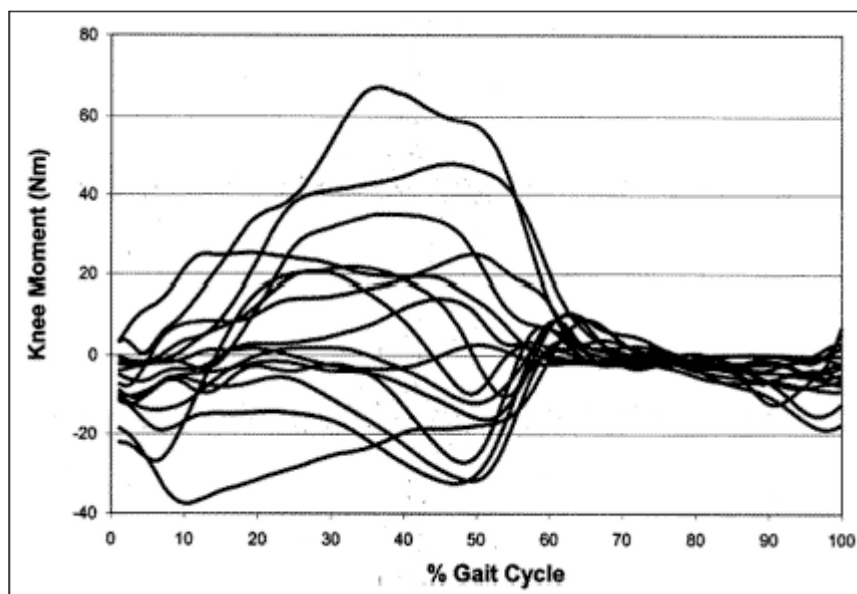

Figure 8. Dynamic knee moments of SCO users. Peak demand occurs during stance. Knee moment values greater than zero tend to collapse the knee joint (i.e., are an external knee flexion moment). Conversely, knee moments less than zero tend to lock the knee in full extension (external knee extension moment). Knee moment data were not collected from six participants because they used walking aides.

20

Plane	Aluminum	Stainless steel	Titanium
Sagittal	83	180	290
Coronal	22	48	77
Transverse	19	41	66

Table 3. Theoretical uniaxial yield loads (Nm) for a single upright bar measuring 5 . 19 mm

In addition to the peak demand, it must also be recognized that all users created an external knee flexion moment during terminal stance (i.e., 60% gait cycle), and this knee moment must be overcome to release an SCO during gait. These functional demands must be recognized during the design of KAFOs.

### MODULATING FACTORS

KAFOs must be designed to meet the demand of the user. Users will differ in many characteristics. Among these are the pathology, age, BMI, alignment, and residual muscle strength. As noted above ( Figure 8 ), these can lead to varying structural demands on the KAFO. A simple grid based on patient weight and activity level ( Figure 3 ) may not totally encompass the functional demand of the user.

### PATIENT INTERFACE

Most often, straps or bands are used to position the KAFO on the patient. A 3-point or 4-point force control system is used to provide orthotic control. The efficacy of an orthosis in controlling or correcting motion is influenced by the distance between the joint axis and the point of force application. The contour of the orthosis and the degree of tightness of the straps necessary to secure the orthosis determine the magnitude of the forces and pressures applied to the soft tissues. Moreover, malalignment and knee motion also contribute to increased joint torques. These forces and torques have significant impact on the soft tissue integrity. At the patient/orthosis interface, stability and comfort are achieved by having the force distributed over a large area to reduce pressures. Leather-covered metal cuffs, molded plastic cuffs, or pads are used to reduce the interface pressures. Carefully controlled large surface interfaces are used to achieve minimal tissue pressure. However, prolonged loading, even at low levels of pressure, may cause damage. Anatomical sites with substantial soft tissue can tolerate higher pressures than bony prominences or areas containing superficial blood vessels and nerves. However, no data currently exist to specify the pressure levels needed to achieve blood flow over bony prominences.

### FABRICATION

KAFOs are custom-made orthoses. The fabrication process involves four major steps. The process begins with making accurate measurements of the limb followed by taking a negative impression (cast). Next, a three-dimensional positive model of the lower limb is created and then modified to incorporate the desired control features. The orthosis is then created around the positive mold. The final step is the fitting of the device to the patient. Most often, this process occurs in the orthotist's office. More recently, central fabrication is being undertaken to yield a custom orthoses. The advantage of central fabrication results from economies of scale and enhanced quality control processes. Computer-aided design and computer aided manufacture (CAD/CAM) has been used as an alternative method of prosthetic fabrication since the 1960s. CAD/CAM systems are fast and efficient as well as an economical alternative for fabrication. The role of CAD/CAM in the manufacturing of KAFOs needs to be explored and defined.

### STANDARDS

National and international standards exist to protect consumers, commercial entities, and the environment. Consumer protection includes biological safety, electrical safety, and mechanical safety. Biological safety standards would address biocompatibility issues. In the United States, the Food and Drug Administration (FDA) would have jurisdiction. At this time, no biocompatibility standards are in place for all-mechanical orthoses. Electrical safety standards exist for medical equipment and have been harmonized with the European Union (CE mark, see below). The mechanical requirements for the general materials used in orthotics are controlled by the American Society for Testing and

Materials (ASTM) and the International Organization for Standardization (ISO). Generally, these groups specify requirements and test methods that can be adopted as industrial, national, or international standards. Ultimately, they may be introduced into legislation and gain the force of law. The CE mark is a collection of standards that have been incorporated into the European Union trade laws. It has been built to a great extent on ISO standards. In addition to technical standards, the CE mark ensures that a product complies with essential requirements that may include health, safety, and environmental protection concerns. ISO standards are more comprehensive for prostheses than orthoses. As of this writing, ISO standards define test procedures for knee orthosis components, but they do not set minimal load limits on componentry. There are no ISO standards addressing the mechanical performance of SCOs, HKAFOs, RGOs, or hybrid FES-orthoses systems.

## EMERGING TECHNOLOGY

Engineering technological advances will provide exciting new opportunities for KAFO designs. The pace of technological change continues to accelerate. The number of disruptive technologies emerging from the biology, nanotechnology, and information fields is likely to cause radical changes in the way KAFOs are designed and produced. Biomechanics is the interdisciplinary study of biology, mechanics, and electronics. A focus on the development and optimization of mechatronic systems using biological and medical knowledge is occurring. Future changes in KAFO designs are likely.

## POWERED EXOSKELETON

Humans have long used armor as an artificial exoskeleton for protection, especially in combat. Orthoses are a form of exoskeleton. In the last 5 years, a number of companies and research centers have developed the first practical models of human exoskeletons ( Table 4 ).<sup>36</sup> One of the main uses is enabling a soldier to carry heavy weights (50 to 100 kg) while running or climbing stairs. Originally these efforts ran into fundamental technological limitations. Computers were not fast enough to process the control functions necessary to make the suits respond smoothly and effectively to the wearer's movements. Energy supplies were not compact and light enough to be easily portable. Actuators were too sluggish, heavy, and bulky. Recently, however, systems are becoming more agile. It is thought that military applications may be in field trials within 5 years. The cost of an exoskeleton to an individual or medical application remains to be addressed.

Homayoon Kazerooni University of California, Berkeley	Berkeley's new exoskeleton, Bleex 2, is an agile system that lets a person walk and run while carrying heavy loads strapped to a backpack-like frame
Stephen C. Jacobsen Sarcos Research Corp., Salt Lake City	Sarco's exoskeleton is a full-body system with powered robotic arms and legs. One of the strongest ever built; it can help a person haul 84 kilograms without feeling the load.
Jacob Rosen University of Washington, Seattle	A full-arm exoskeleton controlled by neuromuscular signals, it has 7 degrees of freedom. The goal is to help people suffering from various neurological disabilities.
Francois G. Pin and John Jansen Oak Ridge National Laboratory, Oak Ridge, Tenn.	A tethered bomb-loading exoskeleton enables a human operator to raise a 1000-kg bomb as if it weighed only 3 kg and load it onto an aircraft.
Benjamin T. Krupp Yobotics Inc., Cincinnati	Based on research at the MIT Leg Laboratory, the RoboWalker orthotic leg brace augments or replaces muscle functions. It is awaiting commercialization.
John Dick Applied Motion Inc., Claremont, Calif.	SpringWalker is lower-body exoskeleton that can run at 24 kilometers per hour or carry a 90-kg load at a fast walk. It is awaiting commercialization.
Source: <sup>36</sup>	

Table 4. Exoskeletons project in the United States

## ENERGY RECOVERY/GENERATION

As KAFOs become more sophisticated, they will rely on electronic devices. At present, all of these devices are powered by batteries that have a limited energy storage capacity and add considerable weight. Batteries are being developed that have increased power densities. However, it would be desirable to eliminate the weight of batteries in KAFO applications due to the limited locomotion capabilities of individuals who need KAFOs. Efforts have begun to scavenge energy from a variety of body sources. Several researchers have explored parasitic power harvesting from the energy exuded during heel strike.<sup>37,38</sup> Other investigators have demonstrated that a suspended load backpack, which converts mechanical energy from the vertical movement of carried loads to electricity during normal walking, can generate up to 300 times the energy from shoe devices.<sup>39</sup> These examples illustrate that small amounts of energy can be extracted during locomotion using environmentally friendly energy sources.

## SMART ORTHOSES

Advances in textile technology and material science have led to new products in the area of smart textiles. Smart fabric, (also known as intelligent textiles, electronic textiles, or etextiles) are breaking into the medical, sport, and military industries. Smart fabrics are a \$340 million industry, growing 19% annually and projected to reach \$720 million by 2008. Orthoses are the perfect physical foundation for wearable computers. Currently in development for the defense and aerospace industries, these technologies could easily be integrated into the next generation of smart orthoses. Sensor technologies for the automotive industry to monitor tilt, acceleration, and even location (global positioning system) continue to shrink in size and cost while improving performance. These sensors could be integrated into smart orthoses to record movement, quantify the daily activity of the patient, and provide feedback for rehabilitation. These same data could be transmitted via wireless communication to the health professional in real time to evaluate fit and function or as part of a telemedicine practice. People who use KAFOs are susceptible to increased falls due to the loss of agility with the orthosis. Stumble recovery and fall detection would combine sensor and computing technologies to aid KAFO users in this area. Smart fabrics could also be used to measure skin pressure distribution in patients wearing KAFOs and assure that the pressure thresholds would be low in areas that may cause a decubital ulcer. Thus, the application of advanced computing and sensor technologies in KAFOs would yield an intelligent KAFO with enhanced capabilities.

## RECOMMENDATIONS

The data presented in this paper demonstrate that the engineering aspects of KAFOs are complicated and expensive. Clearly, standards are needed to define the loading conditions KAFOs are expected to withstand in the field. These standards should be based on empirical data

collected under well-defined conditions. From these data, predictive models could also be developed that would provide a framework on which engineers could propose new and improved component designs that would address user needs. These data should encompass a wide range of body types, ages, diagnoses, and ground conditions. Stairs and inclined surfaces are frequently found in the "real world" but overlooked in the laboratory setting. Ambulatory KAFO design and application can also be improved from an engineering perspective by adopting new and emerging technologies. These new technologies would include innovations in material science, sensors, and computing technologies. Developments in material science and fabrication technologies continue in the university, commercial, and military sectors, and these present a potentially rich resource for the orthotics and prosthetics (O & P) community. Technologists should closely follow material science developments and evaluate promising materials for O & P applications. Electronic system integration into ambulatory KAFO systems is underway but will need careful scientific study to define realistic expectations and appropriate application criteria. All of these enhancements need to be undertaken in a cost-conscious manner within reimbursement constraints.

## ACKNOWLEDGMENTS

The authors acknowledge NIH Grant R01HD30150 for support of their research on a logic-controlled electromechanical orthosis and thank Barbara Iverson for careful manuscript preparation.

*Correspondence: Kenton R. Kaufman, PhD, PE, Biomechanics/ Motion Analysis Laboratory, Charlton North L-110L, Mayo Clinic, 200 First Street SW, Rochester, MN 55905; e-mail: .*

*KENTON R. KAUFMAN, PhD, PE, is affiliated with the Biomechanics/Motion Analysis Laboratory, Department of Orthopedic Surgery, Mayo Clinic, Rochester, Minnesota.*

*STEVEN E. IRBY, MS, is affiliated with the Biomechanics/Motion Analysis Laboratory, Department of Orthopedic Surgery, Mayo Clinic, Rochester, Minnesota.*

## References:

1. Benson V, Marano MA. Current estimates from the national health interview survey, 1995. National Center for Health Statistics. *Vital & Health Statistics Series 10*. UI: 9914773, October 1998.
2. Russell JN, Hendershot GE, LeClere F, Howie LJ. Trends and differential use of assistive technology devices: United States, 1994. *Adv Data Vital Health Stat No. 292*, 1997.
3. US Department of Commerce. Persons using devices and/or features to assist with impairments, by age: 1990, 1994. Washington, DC.
4. Kaplan LK, Grynbaum BB, Rusk HA, et al. A reappraisal of braces and other mechanical aids in patients with spinal cord dysfunction: results of a follow-up study. *Arch Phys Med Rehabil* 1996;47:393-405.
5. Phillips B, Zhao H. Predictors of assistive technology abandonment. *Assist Technol* 1993;5:36-45.
6. Barnett S, Bagley A, Skinner H. Ankle weight effect on gait: orthotic implications. *Orthopedics* 1993;16:1127-1131.
7. Mattsson E, Brostrom LA. The increase in energy cost of walking with an immobilized knee or an unstable ankle. *Scand J Rehabil Med* 1990;22:51-53.
8. Cerny K, Waters R, Hislop H, Perry J. Walking and wheelchair energetics in persons with paraplegia. *Phys Ther* 1980;60: 1133-1139.
9. Travolta R. Stance control revolutionizes knee bracing. *Biomechanics* 2002;9:53-62.
10. Windler FH. German Patent 304,926. April 15, 1918.
11. Lehmann JF, Stonebridge JB. Knee lock device for knee ankle orthoses for spinal cord injured patients: an evaluation. *Arch Phys Med Rehabil* 1978;59:207-211.
12. Malcolm LL, Sutherland DH, Cooper L, Wyatt M. A digital logic-controlled electromechanical orthosis for free-knee gait in muscular dystrophy children. *Orthop Trans* 1980;5:90.
13. van Leerdam NGA. The Swinging UTX Orthosis: Biomechanical Fundamentals and Conceptual Design. University of Twente: Utrecht, The Netherlands, 1993.
14. Kaufman K, Miller L, Sutherland D. Gait asymmetry in patients with limb-length inequality. *J Pediatr Orthop* 1996;16:144-150.
15. Suga T, Kameyama O, Ogawa R, et al. Newly designed computer controlled knee-ankle-foot orthosis (intelligent orthosis). *Prosthet Orthot Int* 1998;22:230-239.
16. van Leerdam NGA, Kunst EE. Die neue bienorthese UTX-Swing: Normales gehen, kombiniert mit sicherem stehen. *Orthopadie-Technik* 1999;6:506-515.
17. McMillan AG, Kendrick K, Michael JW, et al. Preliminary evidence for effectiveness of a stance control orthosis. *J Prosthet Orthot* 2004;16:6-13.
18. Rietman J, Goudsmit J, Meulemans D, et al. An automatic hinge system for leg orthoses. *Prosthet Orthot Int* 2004;28:64-68.
19. Hebert JS, Liggins AB. Gait evaluation of an automatic stance control knee orthosis in a patient with post-poliomyelitis. *Arch Phys Med Rehabil* 2005;86:1676-1680.
20. Irby SE, Bernhardt KA, Kaufman KR. Gait of stance control orthosis user: the dynamic knee brace system. *Prosthet Orthot Int* 2005;29:269-282.
21. Kobetic R, Marsolais EB, Triolo RJ, et al. Development of a hybrid gait orthosis: a case report. *J Spinal Cord Med* 2003;26: 254-258.
22. Goldfarb M, Korkowski K, Harrold B, Durfee W. Preliminary evaluation of a controlled-brake orthosis for fcs-aided gait. I *IEEE Trans Neural Syst Rehabil Eng* 2003;11:241-248.
23. Greene PJ, Granat MH. A knee and ankle flexing hybrid orthosis for paraplegic ambulation. *Med Eng Physics* 2003;25:539-545.
24. Ferguson KA, Polando G, Kobetic R, et al. Walking with a hybrid orthosis system. *Spinal Cord* 1999;37:800-804.
25. Yang L, Granat MH, Paul JP, et al. Further development of hybrid functional electrical stimulation orthoses. *Artif Organs* 1997;21:183-187.
26. Sykes L, Ross ER, Powell ES, Edwards J. Objective measurement of use of the reciprocating gait orthosis (RGO) and the electrically augmented RGO in adult patients with spinal cord lesions. *Prosthet Orthot Int* 1996;20:182-190.
27. Solomonow M, Reisin E, Aguilar E, et al. Reciprocating gait orthosis powered with electrical muscle stimulation (RGO II), II: medical evaluation of 70 paraplegic patients. *Orthopedics* 1997;20:411-418.
28. Marsolais EB, Kobetic R, Polando G, et al. The Case Western Reserve University Hybrid Gait Orthosis. *J Spinal Cord Med* 2000;23:100-108.
29. To CS, Kirsch RF, Kobetic R, Triolo RJ. Simulation of a functional neuromuscular stimulation powered mechanical gait orthosis with coordinated joint locking. *IEEE Trans Neural Syst Rehabil Eng* 2005;13:227-235.
30. Shurr D, Michael JW. *Prosthetics and Orthotics*. 2nd ed. Upper Saddle River, NJ: Prentice Hall; 2002.
31. Lehnis HR. Orthotics: The state of the art. *J Rehabil Res Develop* 1993;30:vii-viii.
32. Lunsford TR. Strength in material. In: Goldberg B, Shus JD, eds. *Atlas of Orthoses and Assistive Devices*. St. Louis: Mosby;1997: 39-40.



33. Smith EW, Juvinal RC. Mechanics of orthotics. In: Redfords JB ed. *Orthotics, Etc.* Baltimore: *Williams & Wilkins* ;1986:21–51.
34. Lusardi MM. Principles of orthotic design. In: Lusardi M, Nielson CC, eds. *Orthotics & Prosthetics in Rehabilitation*. Boston: Butterworth-Heinemann; 2000:77–87.
35. Centers for Disease Control. Body mass index calculator. <http://www.cdc.gov/nccdphp/dnpa/bmi/calc-bmi.htm> , National Center for Chronic Disease Prevention and Health Promotion, 2004.
36. Guizzo E, Goldstein N. The rise of the body bots. *IEEE Spectrum* 2005;42:50–56.
37. Shenck MS, Paradiso JA. Energy scavenging with shoe mounted piezoelectrics. *IEEE Micro* 2001;21:30–42.
38. Parker M. Ambient Energy Harvesting [Thesis]. Electrical Engineering Division, University of Queensland: Brisbane, Queensland, Australia, 2003.
39. Rome LC, Flynn L, Goldman EM, Yoo TD. Generating electricity while walking with loads. *Science* 2005;309:1725–1728.

**Source:** *Journal of Prosthetics and Orthotics* 2006; Vol 18, Num 3S, p 175

**URL:** [http://www.oandp.org/jpo/library/2006\\_03S\\_175.asp](http://www.oandp.org/jpo/library/2006_03S_175.asp)