

A Knee Brace Design to Reduce the Energy Consumption of Walking

by

Matthew R. Carvey

Submitted to the Department of
Mechanical Engineering in Partial
Fulfillment of the Requirements for the
Degree of

Bachelor Of Science

at the

Massachusetts Institute Of Technology

April 2005 [June 2005]

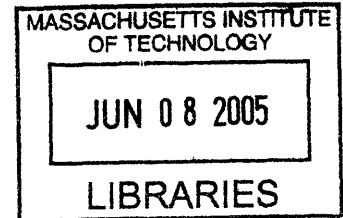

© 2005 Matthew R. Carvey. All rights reserved.

The author hereby grants to MIT permission to reproduce and to distribute
publicly paper and electronic copies of this thesis document in whole or in part.

Signature of Author: _____
Department of Mechanical Engineering
April 29, 2005

Certified by: _____
Neville J. Hogan
Professor of Mechanical Engineering
Thesis Supervisor

Accepted by: _____
Ernest G. Cravalho
Chairman, Undergraduate Thesis Committee

ARCHIVES

A Knee Brace Design to Reduce the Energy Consumption of Walking

by

Matthew R. Carvey

Submitted to the Department of Mechanical Engineering
on April 29, 2005, in partial fulfillment of the
requirements for the Degree of Bachelor of Science in
Mechanical Engineering

ABSTRACT

Recent research into the mechanics of walking indicates that a quasi passive wearable device could be created which dramatically reduces the metabolic energy used in walking especially when the wearer is carrying additional torso weight. Target population groups include military personnel who must carry heavy battle packs and body armor, hikers, letter carriers, and the quasi disabled. This latter group includes a significant fraction of the elderly who have reduced leg strength and/or higher weight torsos. The device is called PUUMA, an acronym for Personal Unpowered Universal Mobility Assistant.

Though walking has been studied extensively, there appears to be a limited understanding of the interplay between the kinetic and potential energy of the torso when driven by legs that can store and release energy. This thesis introduces a simplified model which enables simulation of the entire walking process including the epoch following heel strike. One simulation goal was to explore the knee spring properties which enable lossless walking. Simulations show that there are two knee spring configurations which allow for lossless walking. It is also shown that the percentage of kinetic energy transferred to a knee spring can be a significant fraction of the torso kinetic energy.

PUUMA's basic idea is the incorporation of torsion springs at the knee joints which absorb torso kinetic energy following heel strike and then release that stored energy later in the step. An application of the capstan effect is introduced which enables a practical implementation of two knee spring configurations. In particular, the design allows the thigh and shank to be dynamically coupled to a microprocessor controlled knee spring thereby allowing both unimpeded leg swing and kinetic energy transfer to the knee spring. Another use of the capstan effect is introduced which allows for a microprocessor controlled brake that can freeze the knee at its maximum torsion and then release it later in the walking cycle. A design is shown which embodies the architectural ideas created. Several of the key components were designed, prototyped and tested.

Thesis Supervisor: Neville J. Hogan

Title: Professor of Mechanical Engineering

Acknowledgments

I would like to thank Professor Neville Hogan for allowing me the opportunity to pursue this thesis. It holds significant emotional value for me after my accident of last year. I would also like to thank Daniel Paluska for his help directing me towards relevant information and his general insight into this subject. I would also like to thank Professor Arthur Kuo, the author of Dynamics Workbench (a *Mathematica* Application) used in the simulations and for many of the papers that provided me with valuable information.

I also want to thank the researchers at the Powered Prosthetics Institute (PPI) where I interned for the last two summers working on powered leg assist devices for the disabled. Much of the inspiration and knowledge base for this thesis came from those two summers of work. I would also like to thank my dad, Philip P. Carvey, for introducing me to such an exciting problem and an unmentionable amount of time and personal help. I would also like to thank my mom, Barbara A. Carvey, for proofreading assistance.

Table of Contents

Introduction.....	5
Prior Art	8
Flexfoot	9
SpringWalker	10
Patent Number 4,872,665	10
Patent Number 4,967,734	11
Comments on Prior Art	13
First Order Walking Theory	14
Modeling Gait Behavior.....	14
Fundamentals	15
Gait Measurements.	16
Walking Energy Consumption	18
Geometric Constraints	18
Kinetic, Potential, Knee Spring Energy Transfer During Heel Strike.....	21
Heel Strike Seg Angle and Kinetic Energy Loss	22
Knee Stiffness and Kinetic Energy Loss.....	23
Lossless Walking/Running.....	24
PUUMA Requirements.....	28
PUUMA Architecture.....	30
PUUMA Design	33
Spring Design.....	33
Spring Finite Element Analysis.....	35
Composite Spring Prototype.....	37
Latching/Braking Mechanism.....	39
Interface with Human Body.....	43
Tissue Compression.....	43
Hyperextension Stop.....	44
Brace Positioning.....	44
Critical Dimensions.....	44
Human Adaptability.....	44
Actuator.....	44
Control System.....	47
Structural Design.....	48
Conclusion.....	49
Bibliography	51

1 Introduction

Walking is one of the most common human activities. It is estimated that the world's human population walks over twelve quadrillion steps per year. It is therefore surprising that there appears to be no generally available non-motorized devices for reducing the metabolic cost of human locomotion other than bicycles and other wheeled devices. In general, existing walking assist devices (e.g. knee braces, crutches, canes) enable the quasi disabled to walk, but do not reduce the metabolic cost of walking. Recent research at Powered Prosthetics Institute has suggested that a low cost (<\$200), light weight (<50 Newtons) device can be developed to dramatically reduce the metabolic cost of human walking especially when the user is carrying a heavy backpack. This thesis discusses the theory, prototype design and preliminary device component measurements of a device specifically designed to reduce the metabolic cost of human locomotion. The device is called PUUMA for Personal Unpowered Universal Mobility Assistant.

There appear to be two significant population groups which would benefit from wearing PUUMA devices, the quasi disabled and military personnel. The quasi disabled includes those who have a high torso mass to leg strength ratio and those with joint problems. A significant fraction of the growing elderly population fall into the quasi disabled category and would benefit from a device that reduces the fatigue associated with walking. Those in good physical shape who must walk for significant periods of time carrying significant weight would also find substantial benefit in wearing a PUUMA. For example, soldiers typically carry a 300 Newton battlepack in addition to 150 Newtons of body armor for extended periods each day. While soldiers are typically in superb physical shape, the added weight induces both fatigue and reduced mobility. PUUMA can offer soldiers the ability to wear more body armor and have increased mobility and endurance. In addition, recreational hikers and park rangers could hike further with less fatigue. Police, security personnel and hikers may also benefit by wearing PUUMAs.

Many researchers have studied walking and running. Although hundreds of papers have been written, it is surprising how little is known about the walking process from an energy consumption point of view. Even research in the amount of mechanical work required to walk at a given speed is full of inaccuracies. A mechanical engineer may ask questions such as, "What is the power consumption in joules/second of a person of mass M walking at V meters per second." In the walking research world, researchers measure metabolic energy consumption by measuring the oxygen consumption for a certain activity and subtracting the oxygen consumption when that individual is at rest. [33] A conversion factor between oxygen consumption and energy consumption can be created by placing a person on a device which can measure the amount of work done. This conversion rate of O_2 consumption to mechanical work is at best a gross approximation and is subject to a large variance. For example, in many human activities, muscles contract to create a force (e.g. standing with bent knees) which increases O_2 consumption but produces no work.

In both walking and running, torso weight is alternately transferred between the left and right legs. At the beginning of each step (characterized by the heel of the new stance leg first touching the ground), the torso is both moving forward and downward. The function of the stance leg after heel strike is to change the downward velocity from a negative (i.e. downward) to positive (i.e. upward) direction. Most of the metabolic energy consumption of walking/running is consumed in this process of changing the torso's downward velocity to an upward velocity. PUUMA utilizes a latchable knee spring to change the downward velocity of the torso to zero following heel strike. At zero downward velocity, the knee angle is locked thereby preventing the knee spring from immediately returning the stored energy back into the torso. At the time of knee spring latching, the angle between the ankle and the center of mass of the torso is well before vertical. If an unlatched knee spring were to be used, the knee spring would push the torso upward, but would also push it backward which is not helpful for walking. Instead, the system is allowed to continue rotating around the stance leg until the time that heel lift would normally occur. At this time, the energy stored in the latched knee spring is released into the system thereby pushing the torso upward and forward.

Chapter Two, which discusses prior art, will show that many previous inventors have looked at this prob-

lem. Given that no device which solves this problem is on the market, it is clear that past inventors have not succeeded in finding a solution. One of the first questions is “Why not?” This author believes the reason is twofold. First, there appears to be a limited understanding of the interplay between kinetic energy, potential energy and leg thrust during the walking process, especially after heel strike. Second, advances in microprocessors, high speed computers, advanced composite materials, and MEMS sensors allows complicated ideas to be implemented more easily. It is the premise of this thesis that gaining a good understanding of the walking/running process from a theoretical viewpoint and then applying modern technological advances will allow for the creation of a practical device.

Chapter Three introduces a simplified theory of walking. Idealized human system models are introduced in which the torso/backpack is a point mass situated at the end of the left and right legs. Each leg consists of a massless shank and massless thigh with a torsion spring at the knee joint. One end of the torsion spring is connected to the thigh. The knee joint is augmented with an implementable mechanism which has four properties:

- a microprocessor controlled mechanism to couple the shank to the other end of the torsion spring;
- a mechanical mechanism to freeze the knee angle when the energy stored in the spring is maximized;
- a microprocessor controlled mechanism to release the energy stored in the spring;
- a microprocessor controlled mechanism to dissipate energy created during periods of positive work.

While perhaps not obvious, the mechanisms mentioned above allow the thigh and shank to rotate freely. This mode of operation is required after toe off to allow the leg to bend during the swing phase of each step. In one design alternative, a torsion spring and control mechanism is situated on either side of the knee. If the spring constant of one side is twice that of the other side, programmable spring constants of 1X, 2X and 3X can be achieved.

With this simplified model, it is possible to study the kinetic, potential and knee spring energy transfers during the entire walking cycle. Simulations were conducted because no analytical solutions to the non-linear differential equations were found. The simulations show that the percentage of kinetic energy that must be absorbed by the stance leg is significantly larger than would be intuitively expected and highly dependent on the angle of the heel strike leg. Moreover, the simulations show that if the knee spring constant value is appropriately chosen based on walking speed and torso mass, the maximum energy transfer to the knee spring occurs just as the hip joint is directly over the ankle joint. If the knee spring constant is properly chosen, the step cycle is both lossless and has identical beginning and ending conditions. The simulations also show that with a fixed knee spring constant and the mechanisms described above, it is also possible to achieve a step cycle which is both lossless and has identical beginning and ending conditions. Freezing the knee angle when the energy stored is maximum and then releasing the spring at the proper time using microprocessor control appears to be simpler than developing a spring having a selectively programmable spring constant.

There is value in understanding why the bicycle is the most efficient locomotion device yet created (and likely to remain so). It gains its efficiency from three factors. First, to decelerate, the bicycle rider dissipates the kinetic energy as heat using brakes. In contrast, the walker decelerates by supplying a force in a direction opposite to the velocity. While this in theory should create positive work usable in a later part of the walking cycle, the walker must consume metabolic energy to supply the force even though it is in a direction opposite to the velocity. Secondly, in bicycle riding, there is virtually no work consumed in supporting the torso weight moving parallel to the ground while moving at a constant velocity. In contrast, in walking there are significant periods of time during each step where the leg muscles must supply a force (costing metabolic energy) which nets no mechanical work. Finally, in a bicycle, a significant percentage of the downward and upward leg thrust used to drive the bicycle is converted into a thrust perpendicular to the gravitational vector. In walking, only a small percentage of leg thrust is converted into forward thrust. Since PUUMA addresses only two of these factors, it is extremely unlikely that the device will ever be as efficient as the bicycle. While not as efficient as a bicycle, PUUMA is likely to allow for substantially improved metabolic efficiency over all terrain operation and may be less expensive, smaller and of lighter weight than a bicycle.

This thesis is organized into seven chapters. Chapter Four discusses the requirements for the device and suggests optimization metrics. Chapter Five discusses various alternative architectures and weighs the decisions for choosing one alternative over another. Chapter Six introduces a preliminary design for the device and describes the fabrication and testing of certain key components. Finally, Chapter Seven concludes the thesis with observations, planned future work and opinions on device feasibility.

2 Prior Art

Given that walking/running is one of man's most common activities, it should not be surprising that inventors have created mobility assist devices in the past. These devices can be classified as either powered or unpowered. Since PUUMA contains a power source for the control electronics and activation mechanism, it must be placed in the powered category although it supplies no power to the walking/running cycle. This thesis shall accordingly focus the prior art descriptions on unpowered assist devices.

Research groups have been working on developing powered lower limb exoskeletons for more than two decades. Vukobratovic created a hydraulically powered exoskeleton (1968), a pneumatically driven exoskeleton (1970-1973), an electrical exoskeleton (1974), and a compact computer controlled active suit for dystrophics in 1980. Ruthenberg (1997) developed a powered gait orthosis (PGO) having one degree of freedom run by a linear DC motor. A dynamic knee brace system was developed by Irby (1999) which allows flexion during swing, with restrictions during stance. It featured foot switches as inputs and a finite state controlled linear solenoid to control the knee. Recently, an intelligent orthosis was developed by Suga (1998) that controls the amount of resistance to joint movement using a rotary encoder and heel switch.

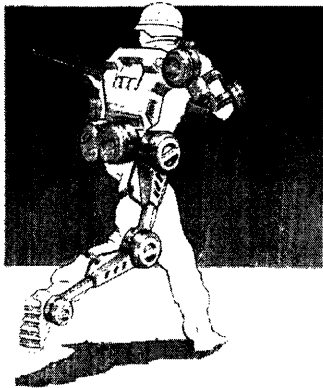

Figure 2.1

In 2001, DARPA initiated a \$50M five year program to develop a powered exoskeleton for military applications. An artist's rendition of the system is shown in Figure 2.1. The goal of the device is augmentation of a soldier's load carrying capability especially carrying body armor and climate control systems. Kazerooni's group at Berkeley (one of the DARPA contract winners) recently demonstrated a backpack carrying system called BLEEX (shown in Figure 2.2) which allows a soldier to carry a 300 Newton backpack with significantly less metabolic energy than without the device.



Figure 2.2

After a patent search, nine US patents appear to be applicable PUUMA prior art. All of the devices except two appear to be impractical to the point that no commercial exploitation has resulted from the patent. One of the patents resulted in a device called Flexfoot, an unpowered prosthetic targeted for amputees. Movies of amputees racing with the devices are remarkable. Another device called SpringWalker, was created with the promise of being the "Amplified Man". The complexity of the device appears to have resulted in extremely limited commercial success.

This chapter discusses a few devices which form the basis of PUUMA prior art, primarily Flexfoot, SpringWalker and two of the nine patents examined. One of the patents discusses a leg propulsion assistance device for improving human mobility, while the other discusses an energy efficient running brace.

2.1 Flexfoot

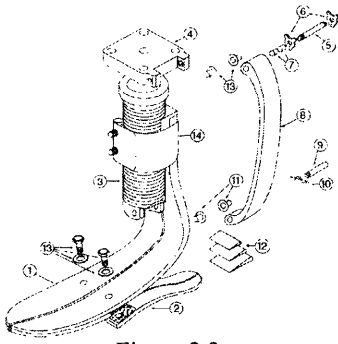

Figure 2.3

After an extensive search for products which have similarities to PUUMA, the only product found having some of the metabolic energy reduction characteristics of PUUMA was Flexfoot. Flexfoot is the trade name for a lower leg prosthetic targeted for amputees manufactured by Ossur Inc., an Icelandic company. The Flexfoot patent (US #4822363) issued in 1989, gave rise to a product family which now has many variants. A diagram of one of the family members is shown in Figure 2.3. An above the knee prosthetic showing the complexity of a typical prosthetic is shown in Figure 2.4. Flexfoot has been quite successful both from a commercial standpoint and by notably improving the quality of life for



Figure 2.4

amputees.

Pictures of runners wearing the Flexfoot while competing in races are shown in Figures 2.5 and 2.6. Flex-

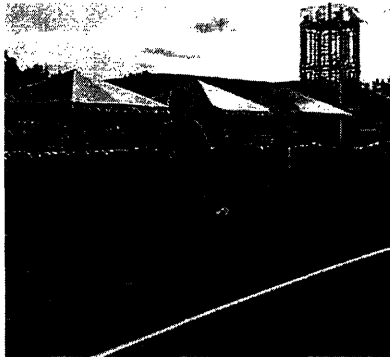

Figure 2.5

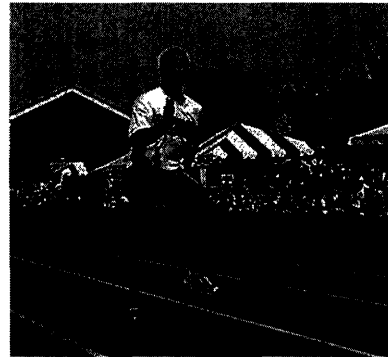

Figure 2.6

foot allows amputees to run surprisingly quickly. Although their stride is noticeably different, some can run 100 meters in under 11 seconds! The Flexfoot spring scheme works by the following two principles: [21]

1. Downward thrust of the torso compresses the spring thereby storing energy which is naturally released after the maximum flexure point is reached. At each speed, the Flexfoot wearer adjusts his/her leg angle at heel strike to make the maximum flexure point occur when the torso apex point is reached. This is why Flexfoot runners have uneven gaits and why Flexfoot has much more limited benefits at lower speeds.
2. Flexfoot also transfers forward kinetic energy of the torso into the spring and effectively mechanically latches that energy until the onset of heel lift. Unfortunately, only a small fraction of metabolic energy can be captured using this effect, but competing devices offer no comparable energy storage and release.

Notwithstanding the success of Flexfoot, it does have deficiencies. There is only one speed and heel strike angle combination that causes the wearer to reach system apex just at exactly the same time as maximum spring compression. This limited speed and heel strike angle relationship places limitation on the wearer's ability to gain maximum metabolic energy reduction. Second, as in almost all existing prosthetics, the angle between shank and foot is fixed. The author has personal knowledge that this "feature" can create significant gait problems when compared to a prosthetic which dynamically varies the ankle angle. A new Ossur product (invented at MIT) addresses the issue by dynamically controlling the knee.

2.2 SpringWalker

SpringWalker is a self-actuated spring-action bipedal device which includes a back-mounted frame attached to the upper torso of the user with articulated leg frames attached to the lower portion of the back frame. US Pat. No. 5,016,869 describes the invention. Unlike the inventions described in subsequent sections, the inventors actually fabricated SpringWalker and started a company (Applied Motion, Inc.) to commercialize the technology. A picture of a man wearing SpringWalker and a diagram taken from the patent are shown in Figures 2.7 and 2.8 [25]

Given the complexity of the design, it is amazing that the inventors were able to actually create a working prototype. After reading the patent, it becomes clear that the governing design problem their invention addressed was how to disengage the energy capture spring at the start of leg swing. Their clever solution also yielded a single spring design. While extremely innovative, SpringWalker does have deficiencies.

SpringWalker is extremely clumsy to use because the user is balancing on feet other than his own without the ability to engage the control muscles normally used in walking. The wearer is perched substantially above ground level, making potentially falls more dangerous. The system is also likely to take a substantial amount of time to put on and take off. Like the Flexfoot, with a fixed spring constant, there is a fixed relationship between speed and heel strike angle at which the stored energy of the spring reaches a maximum at the same time system apex is reached. When the speed/heel strike angle is not matched to the spring constant, metabolic energy is required to compensate. All things considered, however, the author's hat is off to the SpringWalker inventors for creating such a neat machine.

2.3 Patent Number 4,872,665

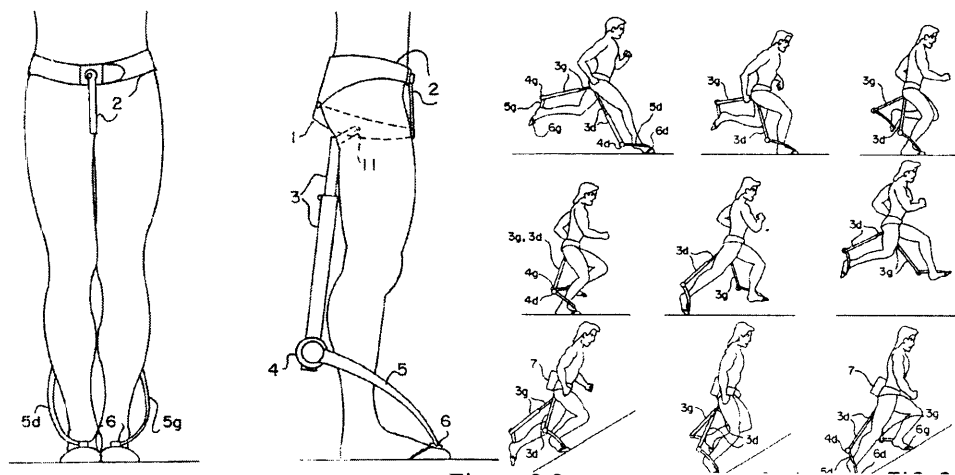

Figure 2.9



Figure 2.7

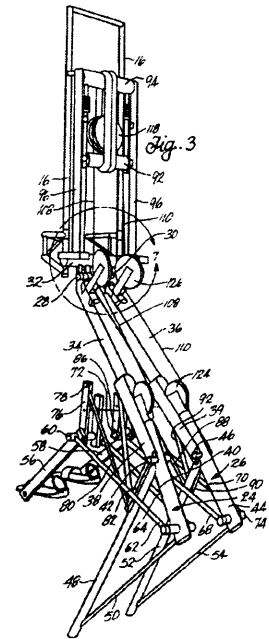

Figure 2.8

A leg-propulsion assistance device for improving human mobility was filed by a French inventor in 1986. The US Pat. No. 4,872,665, granted in 1989, shows many innovative ideas and on the surface has PUUMA-like properties. Diagrams showing a wearer of the device standing, running on level ground, jumping and running uphill are

shown in Figure 2.9. Note that no drawing is shown of the wearer running downhill nor negotiating steps for obvious reasons. [24]

The device provides a saddle supplied with a hip fastening mechanism to support the torso weight during the stance phase of each step. A saddle joint allows for the swiveling movement of two telescopic rods. These telescoping rods can provide an extension force which is derived from a compressed spring or fluid generated under pressure. A link arm at the end of the telescoping rod transmits the extension force to the toe of the user's foot. A mechanism at the link arm telescoping rod joint allows the link arm and foot to be raised at the onset of the swing phase of each step. With allusions to springs and joints disconnecting the spring at the start of the swing phase, the inventor appears to have solved several of the core ideas addressed in PUUMA. With respect to storing and releasing the heel strike torso descent energy, the patent discloses:

“This is why one of the functions of the device according to the invention is to recuperate the energy called into play at this moment so as to restore it during the propulsive phase. For this to occur, the individual must allow himself to sit on the saddle of the device and during this phase must only exert the minimum amount of muscular efforts required to ensure his equilibrium. The device stores energy either through the compression of its propulsion spring or by the compression of a bladder containing a gas, as shall be seen subsequently. In both cases, the alighting absorption function following the leap is also properly respected, thanks to the elasticity of the storage processes.”

No mention is made of the type of fluid/gas, nor are the sizes of the piston/spring components included in the patent. Unlike Flexfoot which does not allow the spring constant to be actively changed, the use of a compressible fluid such as air could potentially provide a mechanism for dynamically changing the system spring constant. Given the vagueness of the implementation details, it is difficult to know whether the patent is applicable to PUUMA or not. It should be noted that the primary thrust of the invention was directed toward a powered system which enhanced a user's performance, not for passively reducing the metabolic energy of walking/running.

2.4 Patent Number 4,967,734

Of the prior art examined, the patent for an energy-efficient running brace (filed in 1988), comes the closest to utilizing the ideas upon which PUUMA is based. As a summary of the invention, the patent states that the running brace transmits the force and energy of the runner's impact from a pelvic harness to a storage means in the running brace and the release of that energy at the proper time to contribute to the thrust of the runner off the running surface. It is not clear whether the inventor really understood the interplay between kinetic, potential and leg energy during the patent write-up but he gets most of the concepts correct. Unfortunately, the emphasis on running severely limited the application of his invention. The five claims of the patent are given below. Note that claim one introduces a mechanism to augment the amount of foot impact stored energy by means of the runner's other limbs. One potential reason is the existence of a patent (U.S. Pat. No. 2,206,234) granted 1940 entitled an Invalid Walking Aid Apparatus. This patent discusses a brace which extends from the foot to the upper leg and has a spring to cushion the impact of foot strike. The patent is dismissed with the comment that contact with the ground is made via a pair of feet each of which is similar to the foot of a pogo stick. [22]

Pat. No. 4,967,734 Claim 1. “In an energy-efficient running brace comprising brace means for supporting and protecting a runner's legs during impact on a running surface and for storing the impact energy for release during thrust, and harness means for attaching the runner's body to said brace means, the improvement comprising auxiliary transmission means for transmitting during flight to said brace means energy generated by movement of the runner's limbs other than foot impact energy, and for releasing said non-foot-impact energy during take-off from said running surface and storage means connected to said brace means for storing said non-foot-impact energy during flight.”

Pat. No. 4,967,734 Claim 2. “the improved energy-efficient running brace of claim 1, wherein said brace means comprises:

- an upper brace rotatable connected to said harness means; and
- a lower brace coupled to said storage means for compressing said storage means and for transmitting said non-foot impact energy from said running surface to said storage means during take-off. “

Pat. No. 4,967,734 Claim 3.” The improved energy-efficient running brace of claim 2, wherein said auxiliary transmission means comprises:

- a storage station proximate to said storage means for using said non-foot-impact energy to compress said storage means; and
- a work station proximate to said limbs for allowing said limbs to work against said storage means by transmitting said limb force to said storage station. “

Pat. No. 4,967,734 Claim 4. “The improved energy-efficient running brace of claim 3, wherein said storage station comprises a first energy storage means and a second energy storage means, each of which comprises:

- a hydraulic transmission mechanism attached to said upper brace;
- a bottom plate rigidly attached to the bottom of said hydraulic transmission mechanism and to said upper brace;
- a ratchet plate rigidly attached to the top of said hydraulic transmission mechanism wherein said ratchet plate moves said lower brace upward, thereby compressing said storage means during flight; and
- storage station ratchet/release means attached to said lower brace through a slot in said upper brace and attached to said ratchet plate for allowing said storage means to expand at the beginning of take-off from said running surface.”

Pat. No. 4,967,734 Claim 5. “The improved energy-efficient running brace of claim 3, wherein such storage station comprises a first energy storage means and a second energy storage means and where said work station comprises:

- a center plate rigidly attached to said lower brace in the vicinity of said limbs;
- an upper hydraulic transmission mechanism located above said center plate and rigidly attached thereto;
- a lower hydraulic transmission mechanism located below said center plate and rigidly attached thereto;
- a top bellows plate rigidly attached to the top of said upper hydraulic transmission mechanism;
- a bottom bellows plate rigidly attached to the bottom of said lower hydraulic transmission mechanism;
- an upper hydraulic tube connecting said upper hydraulic transmission mechanism to said storage station;
- a lower hydraulic tube connecting said lower hydraulic transmission mechanism to said storage station;
- means for rigidly attaching said bottom bellows plate to one of said limbs; and
- a cable attaching said top bellows plate to said limb, wherein movement of said limb in one direction compresses said lower hydraulic transmission mechanism between said bottom bellows plate and said center plate, causing hydraulic fluid to flow through said lower hydraulic tube to said storage station and causing compression of said first energy storage means, and wherein movement of said limb in the opposite direction compresses said upper hydraulic transmission mechanism between said top bellows plate and said center plate, causing hydraulic fluid to flow through said upper hydraulic tube and causing compression of said second energy storage means. “

Since PUUMA utilizes torsion springs located at the knee, a microprocessor controllable mechanism to freeze the torsion spring energy, a mechanism to free the torsion spring from the knee joint just prior to leg swing and a means for dissipating kinetic energy (as would occur from walking/running downhill), it is questionable whether patent infringement has occurred. Nevertheless it is instructive to examine the patent disclosure to see an alternate early implementation.

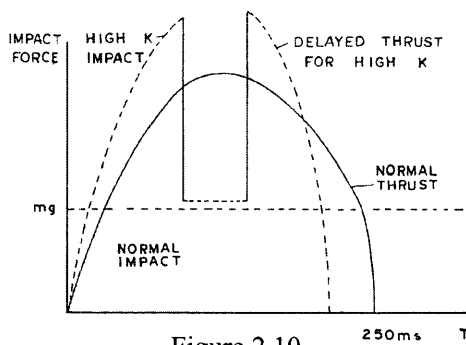

Figure 2.10

The following statement in the patent shows that the inventor clearly knew why the idea of delaying the thrust until after torso apex is a good idea. The graph that the patent refers to is shown in Figure 2.10. “The solid curve in the figure shows the impact force as a function of foot-contact time for the case where there is no delay between impact and thrust. Impact occurs when the curve is rising, and thrust occurs when it is falling. If the roll-over time (the time it takes for the foot to roll over from the heel to the toe) is less than the impact time, the thrust resulting from the expansion of the storage means would push the runner backwards. This limits the value of the storage means spring constant, since the impact time interval is inversely proportional to its spring constant. Thus, for high spring constant

values (high performance), it is necessary to delay the storage means release; for low spring constants this delay is not necessary.”

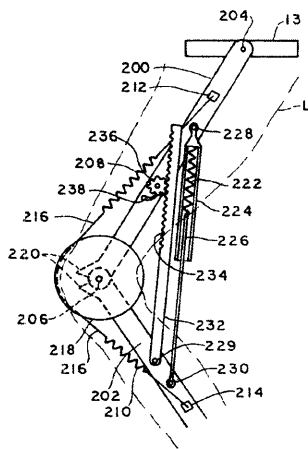

Figure 2.11

The inventor goes on to describe how delay is achieved. He introduces a ratchet/release mechanism activated by a Sylphon bellows (shown in Figure 2.12) and hydraulic mechanisms discussing fluid transfers. Note that no mention is made of the amount of energy needed to release the stored energy nor the forces on the ratchet mechanism. The only energy storage mechanism associated with the knee is described with reference to the figure shown in Figure 2.11.

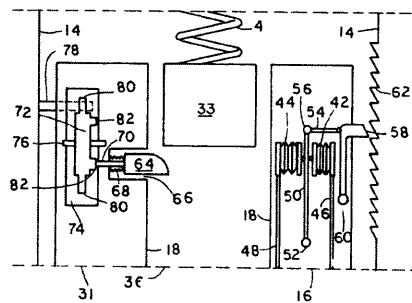

Figure 2.12

The patent is also instructive in what was left out of the disclosure. In particular, no mention is made of how the system is controlled, or how the energy storage mechanism is disconnected from the exoskeleton during the leg swing phases. One can only conclude from reading the patent that it is unlikely that a working prototype

was ever constructed.

2.5 Comments on Prior Art

In addition to the patents described above, there were numerous patents involving shoes and springs. [26,27,28] In all these prior art patents the concept of absorbing the energy of the descending torso at heel strike and then releasing that energy was considered to be a good idea. It is also clear that the implementation of this concept along with a mechanism for releasing the leg during the swing phase of each step has eluded the various inventors. Patent No, 4,967,734 clearly comes closest to understanding the requirements but does not disclose a practical implementation. In fairness to these past inventors, the current availability of simulation tools, high speed computers, microprocessors and composite materials, coupled with a better understanding of the walking/running process makes designing a system significantly easier.

3 Simplified Walking Theory

It is well known that the largest component of metabolic energy consumption in walking and running is associated with producing the upward leg thrust during the stance leg torso support. [33] This period starts at the time that the heel of the new stance leg touches the ground and terminates when the toe of the stance leg leaves the ground. During this period, there is an interaction between kinetic and potential energy of the torso and energy absorbed and released by the stance leg. This chapter introduces models, simulations and explanations to shed light onto this poorly understood interaction.

To gain insight into this interaction, a model is introduced which appears to yield anthropomorphic behavior yet is simple enough to simulate. The model consists of a point mass torso/backpack residing at the end of a leg. The leg is composed of massless shank and thigh elements of equal length with a torsion spring joining the two leg elements at the knee. The spring produces a torque proportional to the knee angle. With this model, the thrust produced by the leg is directly proportional to the spring constant and has an $x/\sin[x]$ knee angle dependency. It should be noted that the human leg can produce a leg thrust which is controllable from zero to approximately five times the person's weight. [37] Moreover, it is clear from ground reaction force measurements that leg thrust is dependent on speed and varies during the walking/running cycle. Simulations will show, however, that the simple model behaves in a surprisingly lifelike manner.

Simulations will show that two alternative schemes demonstrate lossless walking in the simplified walking model. In one scheme, the spring constant of the knee spring is selected such that the maximum energy absorption of the spring occurs precisely at the time that the hip is directly over the ankle. It should be noted that creating a knee spring which can store 150-200 joules of energy, can flex millions of times, and has a microprocessor controllable spring constant is technically challenging. In the alternative scheme, the torsion spring is augmented with a mechanism which mechanically freezes the knee angle at maximum energy storage. Later in the walking cycle, a microprocessor activates a release mechanism which immediately releases the knee, thereby releasing the stored energy into the system. The result is a walking cycle which to a first order has zero energy dissipation.

This chapter has nine sections. Section 3.1 describes the basics of the walking cycle and the tools used in simulating the model. Section 3.2 describes some fundamental laws governing the horizontal and vertical ground reaction forces. Section 3.3 analyzes measurements of joint angles taken from the literature and introduces the concept of a seg (Synthetic Leg) which has been found to be extremely useful in describing walking behavior. It then shows how examining seg behavior allows for simple computation of the energy consumed in changing leg swing direction. Section 3.4 describes accepted formulas of energy consumption versus speed. Section 3.5 creates a first order model of the torso velocity and tilt angle of the torso velocity at the moment of heel strike versus speed. Section 3.6 discusses the energy transfer interaction between kinetic, potential and knee spring energy following heel strike. Section 3.7 shows the amount of kinetic energy transferred to the knee spring as the heel strike leg angle is varied. Section 3.8 focuses on the relationship between leg stiffness and kinetic energy transferred. Finally, Section 3.9 shows that there are two schemes which result in lossless walking/running.

3.1 Modeling Gait Behavior

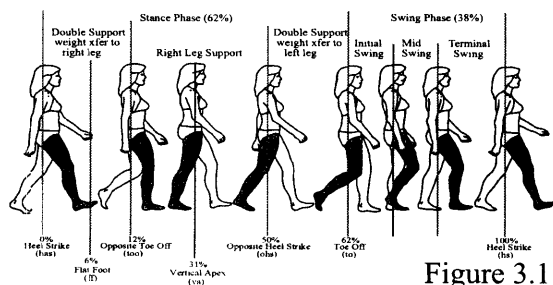

Figure 3.1

A widely used illustration of a woman's stride is shown in Figure 3.1. [33] By definition, a stride starts at heel strike of one foot and continues through to the heel strike of the same foot. In walking, heel strike initiates the double support phase where weight is transferred from one stance leg to the new stance leg. Most researchers accept a Weight Transfer Epoch (WTE) of 12% of the stride period although simulations show a much wider variance. [33] During and following WTE, the torso rotates around the stance leg ankle until the next heel strike. System apex is defined as the point where the hips are directly over the ankle. Typically, a person plan-

tarflexes the foot shortly after the apex point which initiates heel lift. Heel lift is an important aspect of gait because it dramatically affects metabolic energy consumption. Studies have shown that for the majority of a step period, little activation of the leg muscles occurs. Rather, most muscle activation and corresponding metabolic energy consumption occurs during WTE. [33]

Modeling a system with conventional rigid body simulation tools is challenging. The author could not find a simulation analysis of a human model that covering the WTE. The normal mechanism for system modeling is to terminate one analysis at the onset of the WTE epoch and begin a second analysis at the end of the WTE. During the WTE, linear and angular momentum are conserved and collision losses are introduced to model WTE behavior. This energy loss manifests itself by changing the rigid body initial conditions to reflect the energy losses during WTE. Since the leg muscles produce significant forces during this period, it is extremely important to model the WTE in its entirety.

3.2 Fundamentals

The simplest system model consists of a point mass representing the torso with force vectors representing leg actions. Although the model is extremely simple, it provides surprising insights into the walking/running process. The system at five different points during a step period is shown Figure 3.2. Shortly after heel strike, the

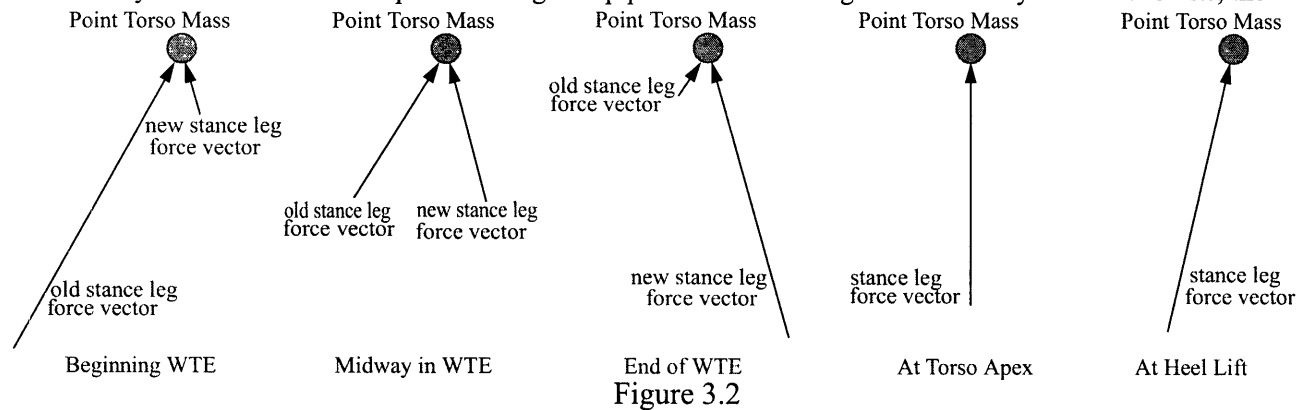

new stance leg produces a small force supporting the torso while the majority of the weight is still supported by the old stance leg. Midway during WTE, the old and new stance legs support the torso weight about equally. Near the end of the WTE, most of the torso weight is supported by the new stance leg with only a small fraction supported by the old stance leg. Shortly after WTE, the old stance leg rapidly begins swinging forward to prepare for its next heel strike. From the end of the WTE to the beginning of the next WTE, the torso is solely supported by the stance leg. At system apex, the system horizontal velocity is at its minimum and the stance leg thrust vector points directly upward. Sometime after system apex, the person excites the calf muscle causing the angle between shank and foot to increase. This action causes the heel to lift off the ground. After a little thought, this model yields several important force properties.

While the torso mass will bob up and down throughout the step period, in order to maintain a constant average height above the ground, the average vertical component of leg thrust must equal torso weight. If this were not true, then an average acceleration upward or downward would occur and the torso would not maintain a constant average height above the ground. Similarly, while the horizontal velocity of the torso increases and decreases, the average net horizontal force produced by leg thrust must exactly zero. If this were not the case, then the average acceleration horizontally would not be zero and the system would change its average velocity.

The implications of an average vertical force vector equal to the torso weight have interesting implications with respect to the value of the net vertical force vector during each step. Vertical ground reaction forces (F_{grfV}) for walking and running are shown in Figure 3.3. [38, 39] The average F_{grfV} for both gaits equals the torso weight W .

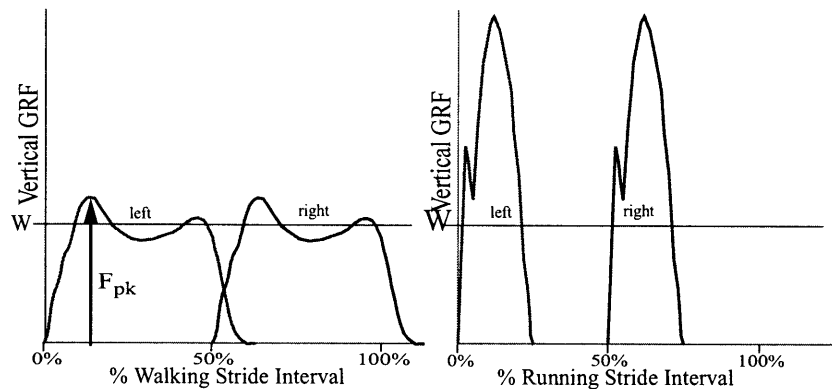

Figure 3.3

Several observations can be made:

1. F_{grfV} during mid step varies widely, from being equal to the torso weight when standing to zero in running. This should be expected because the centripetal force on the torso reduces the effective torso weight as the speed is increased. The transition between walking and running could be defined as that speed at which no overlap occurs between F_{grfV} of the left and right legs.
2. The amount of time that the stance leg can remain in contact with the ground decreases as the speed increases because the legs are of fixed length. This means as speed increases, the peak F_{grfV} must also increase to maintain a constant average F_{grfV} equal to the torso weight.

3.3 Gait Measurements.

Extensive literature is available on measurements of thigh, shank, and foot joint angles. However, the overwhelming majority of these measurements provide only qualitative measurements, meaning that the joint angle functions show the relationship between changes in one joint angle to another. Most often, the joint angles are shown without a grid thus limiting a reader from gaining insight to the actual value of a joint angle at an inflection point. Of the very few measurements published with labeled vertical and horizontal scales, the joint angle functions appear to be inconsistent. For example, the joint angles shown in this section exhibit knee hyperextension. In addition to measurement inconsistencies, additional information such as the persons mass, sex, age, mass distribution, moments of inertia etc. are usually missing. Nevertheless, analyzing measured joint angle functions does give insight into walking behavior as we shall show in this section.

In one paper discussing gait behavior of walking backwards, curves of the joint angles were given for a stride period of 1.2 seconds and a velocity of 1.4 meters per second. [36] The paper specifically indicated that the angles were relative to vertical and horizontal axis. No other information was supplied such as whether the curves pertained to a single person or whether they were group averages, or the age or sex of the person/group or even the leg length. These curves were scanned from the original paper, rotated to give the best fit to the horizontal axis and then manually digitized using calipers. Functions of the foot, shank and thigh curves were created and are shown in Figure 3.4.

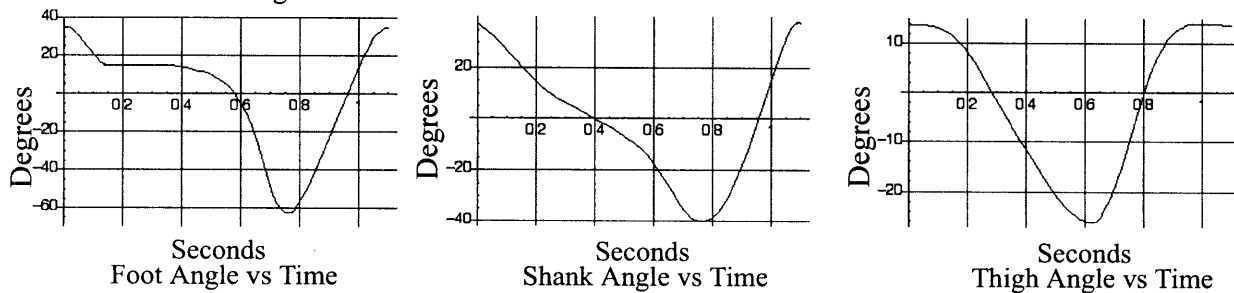
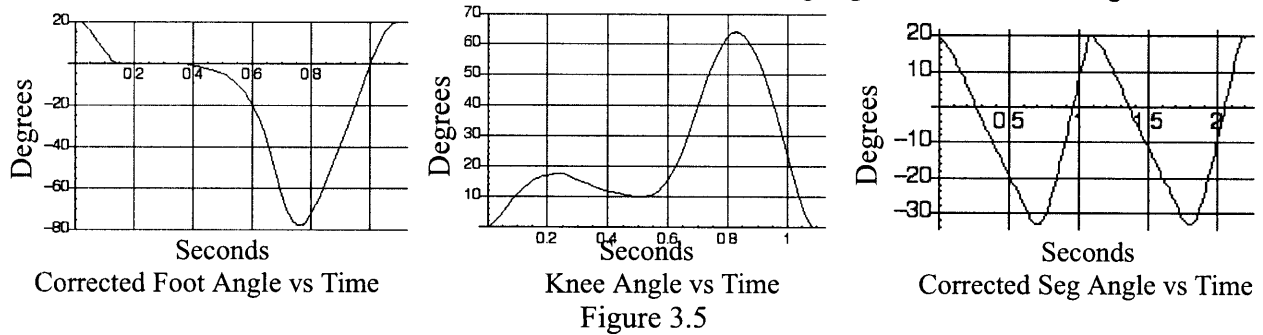

Figure 3.4

Inconsistencies can be seen after a quick inspection of the data. For example, the foot is obviously resting on a flat surface during the interval between 0.15 and 0.4 seconds. A corrected foot angle function can be generated by subtracting 15 degrees from the foot data. The person's knee angle equals the difference between the thigh angle and the shank angle. Since the knee cannot hyperextend, the shank data needs to be corrected to prevent hyperextension. The concept of a Seg (synthetic leg) which has been found useful in describing walking behavior will now be introduced. The Seg connects the ankle and hip. It varies in length during the walking cycle as the knee bends. Neglecting abduction and adduction of the pelvis, the hip sockets of the left and right segs at heel strike must be at the same height at heel strike. This requires a shift of the seg angle data. When these corrections are made to the digitized data, the corrected foot, knee and seg angles are as shown in Figure 3.5.



There are many observations which can be made of these graphs. At heel strike, the foot angle is about 20 degrees and ramps down to zero (the foot flat state) during WTE. Assuming a 12% WTE, it is clear that the torso continues to descend even after the end of the WTE epoch. The torso reaches zero vertical velocity at around 0.225 seconds when the seg angle becomes zero. The zero vertical velocity point occurs at a seg angle of 3.4 degrees. System apex occurs at around 0.25 seconds. Since the next heel strike occurs at 0.55 seconds, the person begins the heel lift process at around 0.38 seconds, substantially after system apex of 0.25 seconds. Note that the knee is not fully extended prior to heel strike (i.e. it is flexed at around 10 degrees). This implies that some metabolic energy is consumed maintaining the torso weight on a flexed knee.

During the WTE (i.e. $0.55 < t < 0.67$), the foot plantarflexes 45.6 degrees. This plantarflexion of the foot applies both an upward and forward thrust to the torso. Note that the foot continue to plantarflex by another 33 degrees until 0.75 seconds even though it is not touching the ground. Between 0.75 seconds and the end of the stride at 1.1 seconds, the foot dorsiflexes by more than 90 degrees in preparation for the next heel strike.

The seg angle curve of one leg shifted in time by 0.55 seconds and superimposed with the unshifted seg angle curve is shown in Figure 3.6. Interesting observations can be made with this data. The first is that the left and right segs rotate with near constant angular velocity during stance and swing phases (1.43 radians/sec and 2.84 radians/sec respectively). If reasonable estimates of the leg's moment of inertia are made, the mechanical power consumption of leg swing changes can be calculated to be about 10 watts. Assuming a torso mass of 100 kilograms, leg swing directional changes constitute about 10% of the body's forward kinetic energy at 1.4 meters/sec.

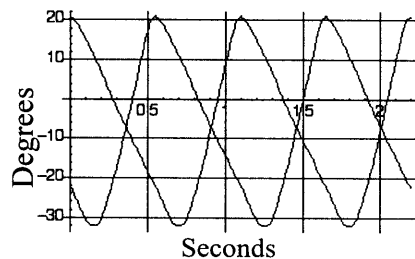

Left and Right Seg angles vs time over two strides
Figure 3.6

3.4 Walking Energy Consumption

There are many papers that examine the metabolic energy consumption of humans. [33] The most commonly accepted mechanism to assess metabolic energy consumption is to measure oxygen consumption during a particular activity. A formula is then applied to estimate metabolic energy consumption. This formula is likely derived from measuring the amount of oxygen consumption need to perform some activity where the mechanical work can be directly measured. In another approach, force sensors are attached to volunteers walking on treadmills to measure the mechanical work produced. A few papers introduce mathematical models to assess energy consumption versus speed relationships. In general these mathematical approaches always attempt to recreate the results of oxygen consumption measurements rather than an independent analysis.

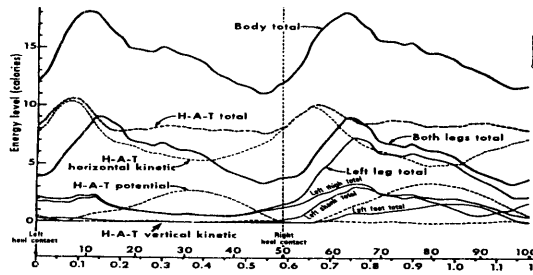

Figure 3.7

Measurements have been attempted of the mechanical work produced by body components during walking. Shown in Figure 3.7 are the energy versus time results of body component energies of a 59 Kg woman walking at 1.22 meters per sec. [33] Work per step corresponds to 49 watts giving rise to a power consumption formula of $0.57 V^2$ watts/kg. Considering the number of variables introduced in the mechanical work measurement apparatus, it should not surprise the reader that these mechanical energy measurements do not correlate well with oxygen consumption measurements.

Measurements of oxygen consumption during walking for various speeds are shown in Figure 3.8. At low speeds, researchers appear to agree on the quadratic growth of energy consumption versus speed. At higher speeds, however, there appears to be some disagreement. Ralston measured a range of subjects and used curve fitting to derived the formula:

$$P_{\text{walking}} = 2.232 + 1.256 V^2 \text{ watts/kg}$$

The 2.232 watts/kg represents the static power consumption of an individual to power activities such a heart, breathing, etc. The $1.256V^2$ term represents the differential energy cost of walking. Zarrugh created a hyperbolic equation which is a better fit for the energy consumption of walking at higher speeds. [33] The

$$P_{\text{walking}} = \frac{1.953 \text{ watts/kg}}{(1-V^2/V_0^2)(1-N^2/N_0^2)}$$

author has come to the conclusion that accurate formulas which describe the metabolic energy consumption of humans walking and running at various speeds are still in the unknown area of science.

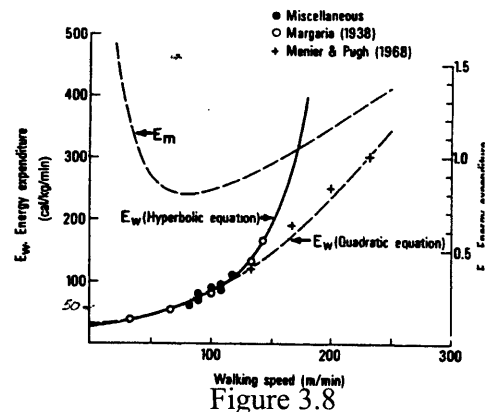

Figure 3.8

3.5 Geometric Constraints

Studies have been made of volunteers walking at constant velocity on a treadmill to determine their preferred step length for various walking speeds. Measurements indicate that the step frequency is proportional to the velocity raised to the 0.58 power with a proportionality constant of 1.539. [16] In the following discussion, we create a first order model using this relationship between step frequency and velocity to determine the forward and downward velocity of the torso at heel strike. Of particular interest is deriving the velocity and direction of the torso at heel strike as functions of forward velocity.

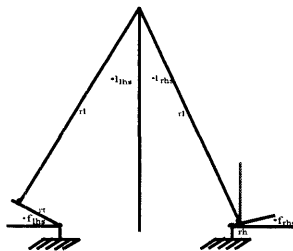

Figure 3.9

A simplified model of the legs and feet at heel strike is shown in Figure 3.9. The model assume no height difference between the front and rear footprints. If both feet are flat on the ground at heel strike, the seg angle of the two legs is identical. When heel lift of the rear leg and dorsiflexion of the forward leg is considered, the seg angles of rear and front legs will be unequal. For example, if the rear foot is in its foot flat state when the front foot is dorsiflexed, the rear leg seg angle will be smaller than the front leg seg angle. Similarly, if the heel of the rear foot is lifted off the ground while the front foot is in its foot flat state, the rear leg seg angle will be larger than the front leg.

Since a person has some degree of control of the rear foot heel lift, it is not clear which of the two seg angles is greater than the other. After an extensively search of the literature, there appears to be no study done on the dorsiflexion and heel lift angles at heelstrike regardless of speed. Based upon analytical measurements, it will be assumed that the heel lift angle in degrees equals K times the forward velocity in meters per second for values of $K=0, 14$ and 28 . The front and rear seg angles as functions of velocity are shown in Figure 3.10.

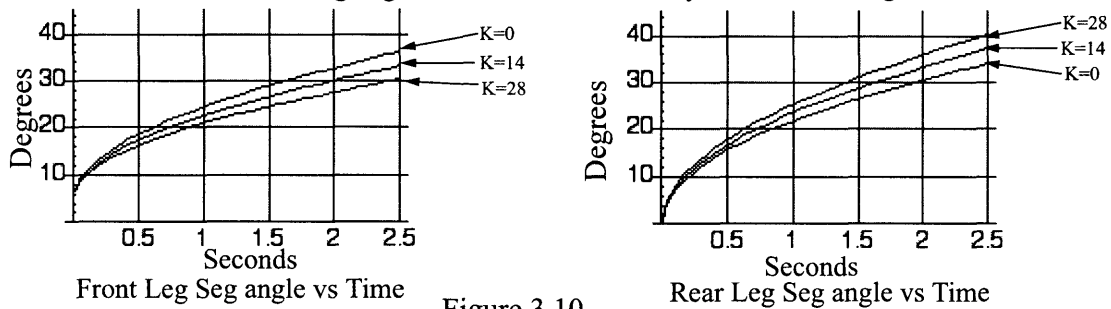
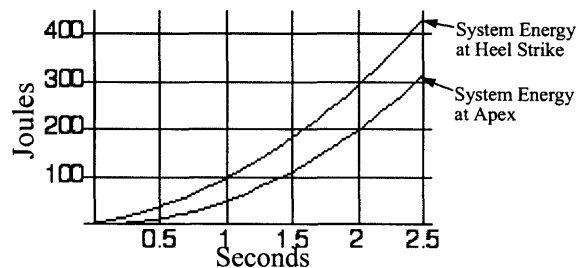

Figure 3.10

An exact determination of the horizontal and vertical velocity of the torso at heelstrike is quite challenging and substantially subject to modeling accuracy. It is straightforward to create a first order determination of the horizontal and vertical velocity by making several simplifying assumptions:

1. The velocity used to compute seg angles equals the torso velocity when the hip is directly over the ankles;
2. The amount of energy pumped into the system via heel lift is negligible;
3. The velocity angle is orthogonal to the line joining hip and toe axle.
4. The effect of the swinging legs on the system energy is negligible and the system energy equals that of the torso and backpack concentrated as a point mass at the hip.

With these first order assumptions, the system energy at heel strike equals the system energy when the seg angle is zero plus the change in potential energy resulting from the hip at heel strike being below the hip height when the seg angle is zero. Assuming a 800 Newtons man is carrying with a 450 Newton backpack, the total system energy at heel strike and the total system energy at system apex is shown in Figure 3.11.



System Energy at apex and heelstrike vs speed
Figure 3.11

Note that the ratio of torso velocity at heelstrike to velocity at apex appears to grow quadratically as the velocity goes to zero. Since the model assumes no pelvic abduction/adduction affects in the model, this should not be surprising. On the other hand, since the amount of metabolic energy at very low velocities is also very small, this modeling problem is only of academic interest.

Heel lift significantly reduces the metabolic energy of walking. Two stick drawings of the front and rear segs together with the rear foot with and without heel lift are shown in Figure 3.12. For the same step length, the

torso falls further without heel lift thereby increasing the magnitude of the velocity at heel strike. Moreover, if a first order assumption that the torso velocity angle is orthogonal to the line connecting hip and the rear leg's rotation axis is made, the torso velocity is tilted further clockwise without heel lift than with heel lift. The combination of a larger torso velocity magnitude and higher tilt angle of the torso velocity yields a larger Y component of the torso velocity.

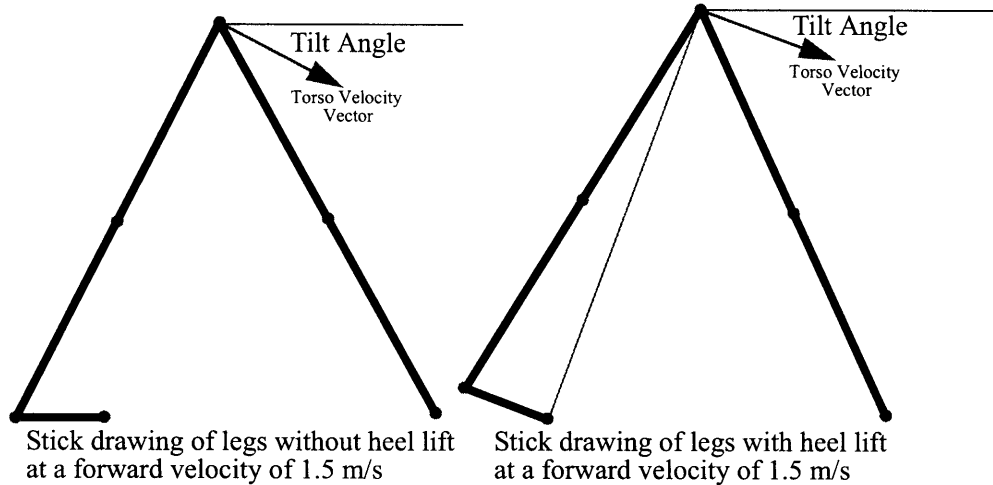

Figure 3.12

Compounding the higher magnitude and larger tilt angle of the torso velocity, the front seg angle is larger in the no heel lift case. As will be seen in the next section, this causes a larger reduction of the forward X velocity during WTE than with heel lift even if the magnitude and tilt angle of the torso velocity were the same. The combination of larger torso velocity, higher tilt angle and larger heel strike seg angle significantly increases the metabolic energy required to transfer weight from the current stance foot to the new stance foot.

Since all the stick figure angles and lengths are known for each velocity, the X & Y components of forward velocity can be computed. The magnitude of the torso velocity at heel strike is shown in Figure 3.13. The rear seg angle (upper curve) and tilt angle of the torso velocity (lower curve) at heel strike are shown in Figure 3.14.

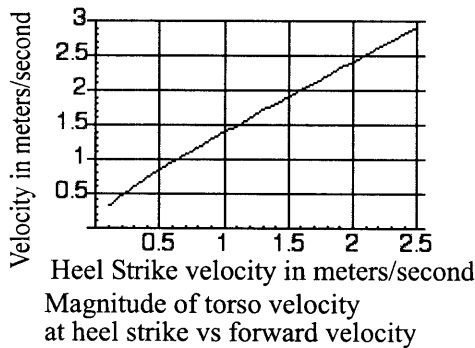

Figure 3.13

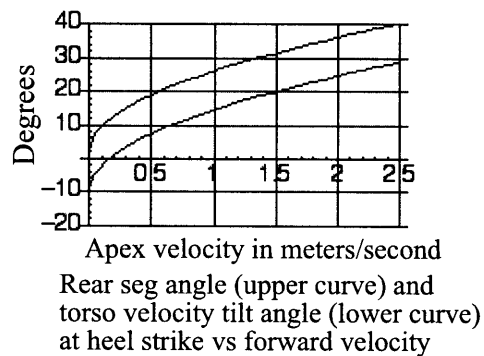
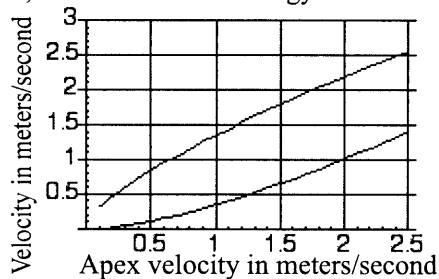

Figure 3.14

Note that heel lift reduces the torso velocity tilt angle by about 11 degrees for all velocities. The next section shows that this has a significant impact on reducing the metabolic energy consumed during WTE.

Shown in Figure 3.15 are the X & Y components of the torso velocity versus apex velocity. Shown in Figure 3.16 are the normalized X & Y components versus apex velocity. For low apex velocity, the X component is virtually equal to the forward velocity. The Y component of the torso velocity at heel strike appears to grow quadratically reaching almost 50% of forward velocity at 2.5 meter/sec. Note that this implies that the torso has significant downward energy which is normally absorbed by the thigh muscles during the WTE. For example, at

2.5 meters/sec, the torso descent energy is over 100 joules.



X component (upper curve) and Y component (lower curve) of torso velocity at heel strike vs forward velocity
Figure 3.15

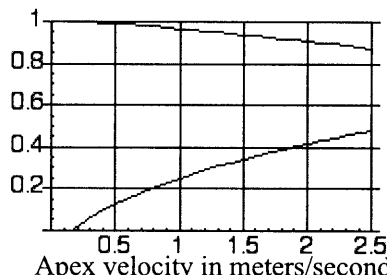

X & Y torso velocity components normalized to torso velocity at heel strike vs forward velocity
Figure 3.16

3.6 Kinetic, Potential, Knee Spring Energy Transfer During Heel Strike

A simplified model of the WTE can be created which shows basic behavior. This model assumes that the ankle does not move, the shank and thigh are massless, a point mass located at the hip represents the torso/backpack, and there is a latching torsion spring knee scheme which represents the behavior of the thigh muscles during WTE. The torsion spring constant is chosen to cause a maximum knee angle of about 28 degrees at a forward velocity of 1.5 meters per second.

The torso velocity and tilt angles computed from the step length versus velocity relationship can be used to create the initial conditions to the shank and thigh angular velocity to allow simulating the system. The initial angle of the shank and thigh can also be computed from the step length versus velocity relationship. At heel strike, the point mass torso/backpack has a forward (i.e. +X velocity) and a downward (i.e. -Y velocity). One would therefore initially expect the torso to move forward and downward. As it moves downward, the torsion spring at the knee will cause an upward force on the torso thereby slowing its descent. If the upward force caused by the knee spring is greater than the torso weight, the Y velocity will become zero.

At heel strike, the system starts out with a kinetic energy (E_0) determined only by the torso velocity. As the downward velocity becomes less negative, the torso falls causing the total system energy to increase. Also during this period, system energy is transferred to the knee spring. A surprising amount of kinetic energy is transferred to the knee spring. A simulation was created of the WTE for a system having a torso/backpack weight of 980 Newtons and a forward velocity of 1.5 meters per second. The seg angle of the heel strike leg, its knee angle and the system kinetic energy versus time are shown in Figure 3.17.

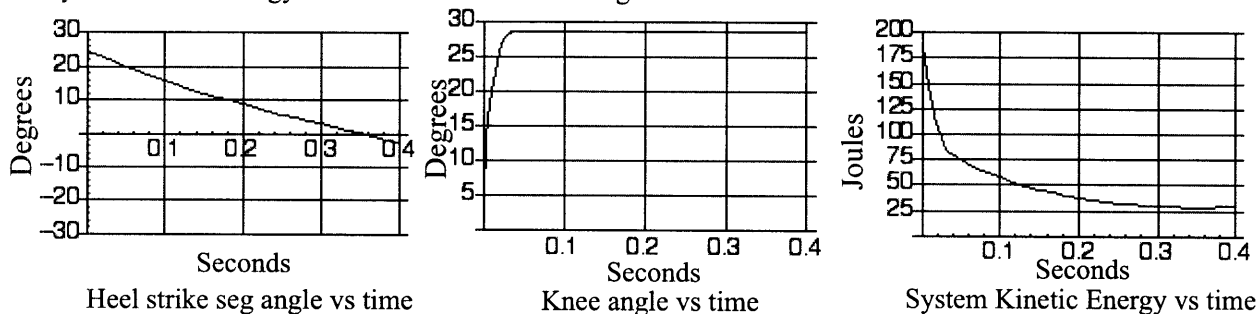

Figure 3.17

At heel strike, the system energy is 186 joules. As can be seen, the drop in system kinetic energy is quite dramatic falling to 28.65 joules 0.35 seconds after heel strike. During the interval from heel strike (i.e. $t=0$), to maximum knee angle (i.e. $t=0.032$), the torso falls 0.72 inches and picks up another 18 joules of system energy. At $t=0.032$, system energy is $186+18=204$ joules of which 110.7 joules has been transferred to the knee spring. Following the maximum knee angle point (at $t=0.032$), the torso rotates around the ankle (since the knee angle

is frozen). This torso rotation at a fixed distance around the ankle further reduces kinetic energy to a minimum of 28.65 joules at $t=0.35$ seconds. Kinetic energy has thus been reduced from a maximum of 186 joules at heel-strike to 28.65 joules when the hip is directly over the ankle, a reduction of 84.6 percent. Note that during the entire simulation interval (i.e. 0->0.4 seconds), the sum of kinetic energy, potential energy and knee spring energy remains constant.

A stick figure diagram of the shank and thighs at 10 millisecond intervals is shown in Figure 3.18. This behavior of the hip motion appears to be similar to that observed in studies of human walking behavior.

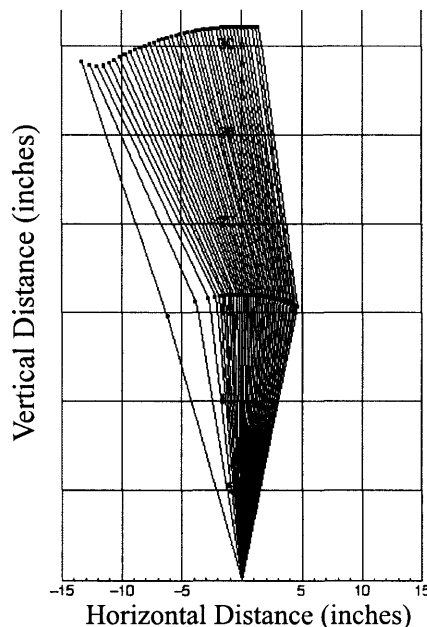

Figure 3.18

At heel strike, the downward velocity component of the torso is 0.659 meters/sec. This implies that the torso downward energy component of the torso's kinetic energy is only 21.77 joules, 11.7% of the total kinetic energy. Intuition might incorrectly suggest that the knee spring need only absorb about 22 joules of energy. The reason a much larger fraction of the torso kinetic energy is absorbed by the leg is that the leg both pushes upward and pushes backward during heelstrike. The amount the heel strike leg pushes backward is strongly dependent on the heel strike seg angle.

In the simulation, the heel strike seg angle was 24.5 degrees. Measurements of human joint angles show that people utilize a smaller heel strike angle than was developed in Section 3.5. For example, at 1.4 meters per second, our simplified model predicts a heel strike seg angle of 23.9 degrees while observations suggest a heel strike seg angle of 18.5 degrees. This discrepancy may be attributable to abduction/adduction of the pelvis which was ignored in the simplified model. If the simulation is repeated using a heel strike seg which better matches observed human behavior, the minimum kinetic energy increases from 28.6 joules to 73.1 joules. This suggests that it is extremely important to understand the relationship between heel strike seg angle and loss of forward kinetic energy. [36]

3.7 Heel Strike Seg Angle and Kinetic Energy Loss

Although Section 3.5 suggested that the heel strike seg angle was strictly determined by average forward velocity, humans can reduce the heel strike seg angle to a surprising degree. Reduction of the heel strike seg angle accomplished by flexion of the knee, increasing the heel lift angle, reducing front foot dorsiflexion, and pelvic rotation in the coronal plane. So far, a 2D model was created based on preferred step length versus speed measurements neglecting second order affects such as pelvic adduction and abduction. This 2D model shows a reduction in kinetic energy during WTE substantially higher than is observed in human gait studies. The assump-

tions used to create the simple 2D model were based on the intuition that the heel strike seg angle did not have such a strong affect of kinetic energy loss. This section shows that the amount of kinetic energy absorbed in the knee spring is strongly dependent on the strike seg angle.

A simulation was conducted where the heel strike seg angle is varied from zero to 25 degrees for a forward velocity of 1.5 meters per second. The normalized energy transferred to the knee spring versus the heel strike

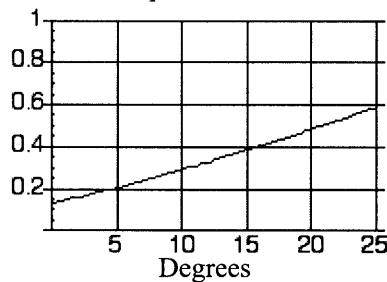

Normalized energy transferred to knee spring vs seg angle

Figure 3.19

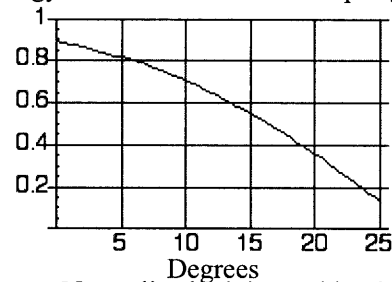

Normalized minimum kinetic energy vs seg angle

Figure 3.20

seg angle is shown in Figure 3.19. The normalized minimum kinetic energy versus heel strike seg angle is shown in Figure 3.20.

As can be seen, at a five degree seg angle, the amount of kinetic energy transferred to the knee spring is only about 20%. As the heel strike angle increases, the amount of kinetic energy transferred to the knee spring increases quasi linearly while the minimum kinetic energy decreases at a much faster rate. Note that for all seg angles, the total of knee spring energy, kinetic energy and potential energy is constant.

3.8 Knee Stiffness and Kinetic Energy Loss

Section 3.2 showed that the average vertical Ground Reaction Force (GRF) must equal to the person's body-weight. At slow speeds, where centripetal forces are negligible, the heel strike leg produces a thrust just slightly larger than torso weight. As speed increases, centripetal force increases. At the speed separating walking and running, the centripetal force exactly equals the torso weight. At this speed, the peak GRF must be about twice the body weight to maintain an average GRF equal to body weight. One paper suggests that swing time reaches a minimum of about 0.32 seconds, a runner's peak velocity is totally limited by the peak leg thrust that can be produced. GRF measurements of Olympic 100 meter runners show a peak GRF of five times body weight. [37]

It is clear that humans modify the leg thrust during WTE dependent on speed. In the simulations done thus far, the leg was modeled via a torsion spring at the knee which froze the knee angle at the point where the kinetic energy transferred to the spring was maximum. Note that the knee spring constant was chosen to result in a maximum knee angle similar to what is observed.

A simulation was performed of the WTE for the same set of conditions as described in Section 3.6 but varying the knee spring constant (i.e. velocity at apex = 1.5 meters per second, seg angle at heel strike = 24.5 degrees). When the spring constant is small, the initial upward thrust force produced by the knee spring is substantially less than the torso weight. This implies that the descending torso actually increases its downward velocity until such point that the upward thrust of the leg equal torso weight. As the spring constant is further increased, a value is reached at which the upward thrust of the leg at knee angles of zero equals the torso weight. At still higher values, the upward thrust of the leg becomes much greater than torso weight.

The normalized energy transferred to the knee spring versus spring constant is shown in Figure 3.21. The normalized minimum kinetic energy versus spring constant is shown in Figure 3.22. Finally, the time at which

the kinetic energy in at its minimum versus knee spring constant is shown in Figure 3.23.

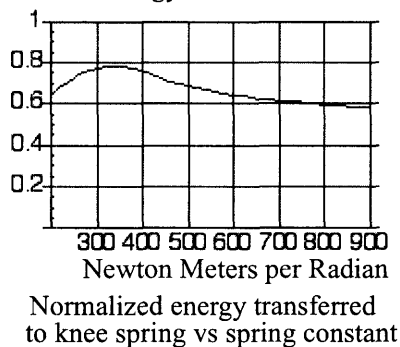

Figure 3.21

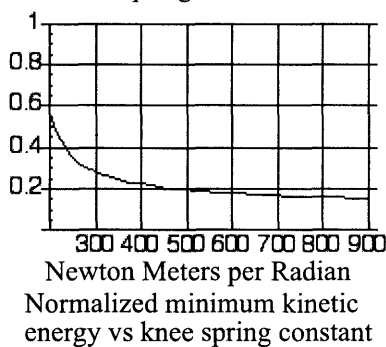

Figure 3.22

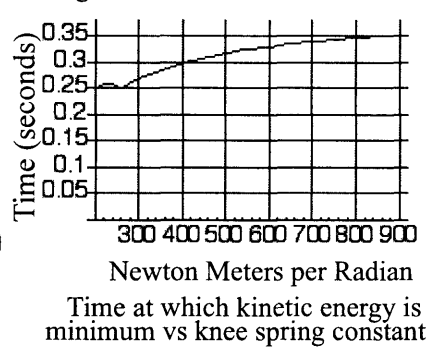

Figure 3.23

As can be seen, for small values of knee spring constant, more than 60% of the kinetic energy is transferred into the spring. The percentage increase to almost 78% when the knee spring constant equals 340 Newton meters per radian and then decreases to less than 60% for large values of knee spring constant. The minimum kinetic energy has no similar maximum. Rather, the percentage of initial kinetic energy lost monotonically decreases to less than 18% as knee spring constant increases.

3.9 Lossless Walking/Running

This thesis focuses on maintaining an average gait speed walking/running on a level surface. In addition, because the left and right leg behaviors are assumed to be identical, the behavior of each step must be identical. These assumptions create the following constraints over each step period:

1. Average horizontal velocity equal the target speed;
2. Instantaneous horizontal velocity at beginning of a step must equal the horizontal velocity at end of step;
3. Average vertical velocity must be zero;
4. Instantaneous vertical velocity at beginning of a step must equal the horizontal velocity at end of step.

While these constraints at first appear trivial, they have important implications in a system where the torso is supported for some fraction of each step period by a stance leg whose foot is pinned to the ground.

The step period is assumed to start at heel strike and consists of a stance period where the heel strike foot is pinned to the ground and an airborne period (of zero duration in walking) where neither foot touches the ground. During the airborne period, the only force acting on the torso is that of gravity. This implies that the horizontal velocity at the start of the airborne epoch equals that at heel strike. In addition, the vertical velocity at the start of the airborne epoch equals the negative of the vertical velocity at heel strike.

Heel strike starts the stance epoch of each step. Assuming the system incorporates a knee spring to create an upward thrust to oppose the gravitational force, the stance leg produces an upward force which accelerates the torso upwards and a backwards force which decelerates the forward horizontal velocity of the torso. Since the average horizontal velocity is assumed to be constant, there must be some interval after the torso has reached the apex point (i.e. hip directly over ankle) where leg thrust increases the forward horizontal velocity of the torso.

Consider a system having a knee spring to slow the descending torso at heel strike but with no latching mechanism to freeze the knee angle. For one particular value of knee spring constant, the maximum knee spring angle occurs at exactly the apex point. During the period from heel strike to apex, the knee spring produces a leg thrust which slows both the downward and forward velocity of the torso. Immediately following the apex point, the knee spring produces a leg thrust which increases both the upward and forward velocity of the torso. It is easy to see that this system with a perfectly chosen knee spring constant produces a symmetrical horizontal and vertical velocity profiles with respect to the time at which apex occurs.

A system model was created with a point mass torso residing on a massless seg which rotates around a fixed ankle point. Leg thrust is zero when the torso to ankle distance is greater than leg length. Leg thrust is positive when the torso to ankle distance is less than leg length and is directed from ankle to torso. The amount of leg thrust models the action of a knee spring. A behavioral model of the knee spring was created which causes the knee spring angle to freeze when the knee angular velocity reaches zero. The seg angle is recorded at the time the knee angle is frozen. The torso then rotates around the ankle until the seg angle equals the negative of the seg angle recorded at the time the knee angle was frozen. When this occurs, the knee is unfrozen thus allowing the stored knee spring energy to be released into the system.

For the first simulation, a knee spring constant is selected which results in the maximum energy being stored in the knee spring at the apex point. The horizontal velocity versus time graph is shown in Figure 3.24.

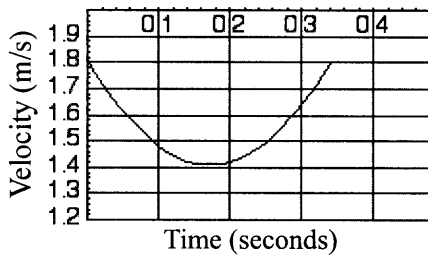

Horizontal Velocity vs time
Figure 3.24

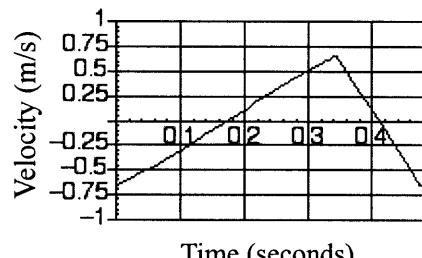

Vertical Velocity vs time
Figure 3.25

The vertical velocity versus time graph is shown in Figure 3.25. For this case, the step period is 0.48 seconds, the step length equals 0.77 meters and the average forward velocity is 1.62 meters per second. Three successive steps are shown in Figure 3.26. Note how natural the hip position versus time looks. The only unnatural aspect of this is that the torso bobbing is almost four inches where normally it would only be about one inch.

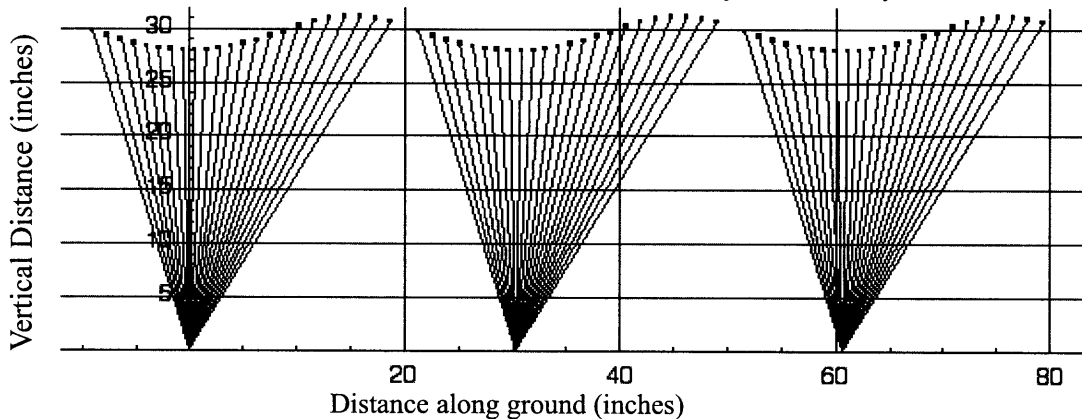
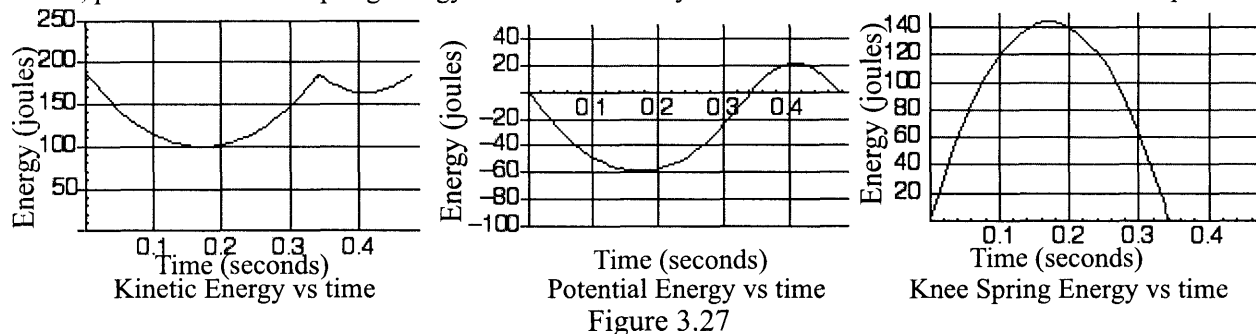

Figure 3.26

The kinetic, potential and knee spring energy vs time can be seen in Figure 3.27. Note that the sum of the

kinetic, potential and knee spring energy is constant at every instant of time over the duration of the step.



In another scheme, a knee spring is employed whose spring constant is fixed. The spring constant chosen equals the largest value to be encountered in normal operation with the maximum backpack weight. With this fixed knee spring, there will be only one set of conditions for which maximum knee angle is reached at the apex point. For all other cases (i.e. lower velocity and/or lower backpack weight) the maximum knee angle is reached prior to the apex point. Augmenting the fixed knee spring is a mechanism to mechanically freeze the knee angle at its maximum value (θ_{freeze} i.e. angle of maximum knee spring energy storage). The time at which this occurs will always be before the apex point where the stance leg seg angle is θ_{freeze} . Following the freeze point, kinetic energy is converted to potential energy until the apex point is reached. Following the apex point, potential energy is converted to kinetic energy until the stance seg seg angle reaches $-\theta_{freeze}$. At point which we call the release angle ($\theta_{release} = -\theta_{freeze}$), the knee spring latching mechanism is electrically activated causing the stored spring energy to be released into the system. From a symmetry standpoint, we expect the dynamic behavior of the system to be identical to the behavior during heel strike except with time reversal.

A simulation was conducted of this alternative scheme. A fixed spring constant of 500 Newton meters per radian is chosen augmented with a mechanism for freezing and unfreezing the knee angle as described above.

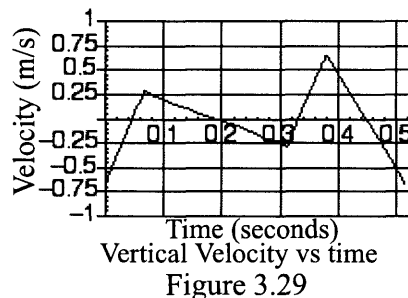
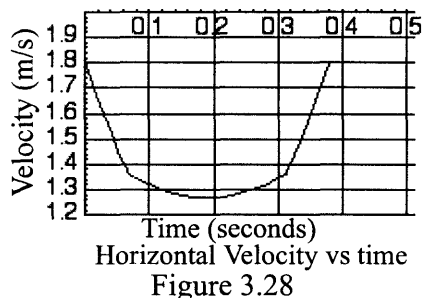

The horizontal velocity versus time graph is shown in Figure 3.28. The vertical velocity versus time graph is shown in Figure 3.29. In this simulation, the step period increases to 0.513 seconds, the step length is virtually identical at 0.77 meters and the average forward velocity decreases to 1.501 meters per second. Note that the interval from heel strike to maximum knee angle has been reduced from 170 milliseconds to about 70 milliseconds and the step period increases. This mandates that the torso rotate losslessly around the ankle for about 240 milliseconds until the knee spring release point. Three successive steps are shown in Figure 3.30. Note that the torso bobbing has been dramatically reduced at the expense of introducing an unnatural double bump in the hip

profile.

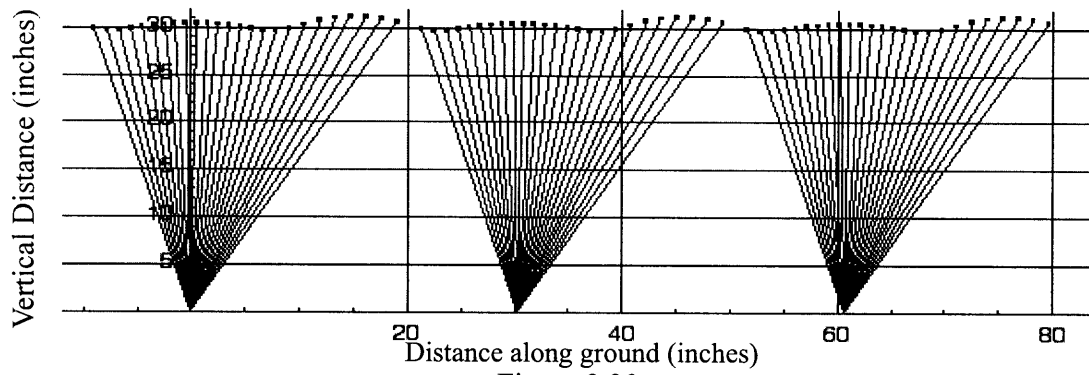

Figure 3.30

The kinetic, potential and knee spring energy vs time is shown in Figure 3.31. As before, the sum of the kinetic, potential and knee spring energy is constant throughout the simulation.

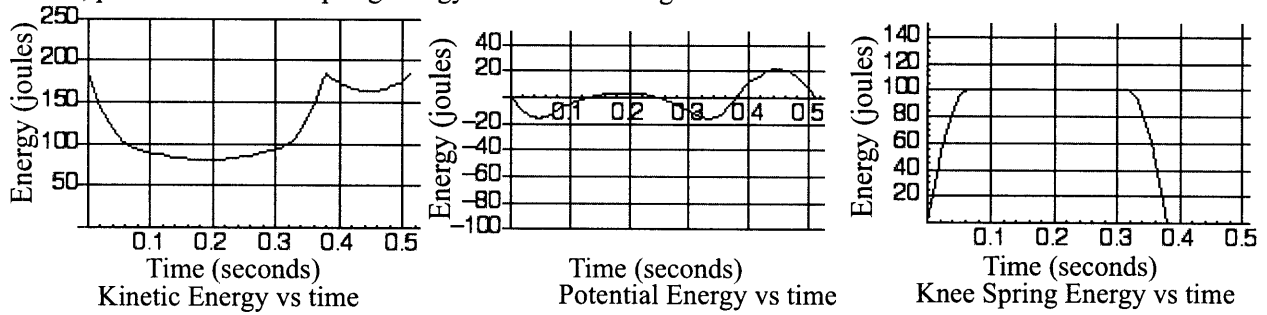

Figure 3.31

4 PUUMA Requirements

Before the architecture of any system can be developed, metrics of goodness for the system must be determined. This is essential to the design process because it allows the designer to sort through ideas and quantitatively eliminate those that will not be favorable in the long run. Metrics of goodness are critical in making design choices and allow the designer to follow a path. In this paper, four metrics of goodness were decided upon.

1. **Simplicity:** Since systems that are simple are generally easier to develop, easier to debug, lower cost, more reliable, and generally more elegant, simple designs will be weighed very highly in the design elimination stage.
2. **Weight:** The whole system should be fairly light for comfort, functionality, and portability since there will be occasions where the device needs to be carried. Although weight is a concern, it will not be weighed as high as simplicity, and reliability.
3. **Cost:** Since one of the goals of this device is to provide walking assistance to those who desire it, cost is a consideration. Since designs that can be manufactured easily are less expensive, manufacturability of the design will be weighed fairly highly.
4. **Reliability:** Since the user could potentially be in a location where failure is extremely inconvenient, it is essential that the device is reliable. Designs that cause considerable wear on components or designs with potential high failure rates should be avoided.

Before designing the specific components of the knee brace system, the architecture as a whole must be decided. While there is some flexibility in the design process, certain fundamental design choices must be made before the detailed designs of the individual components are completed. Once an overall architecture is developed, it becomes substantially easier to do the detailed design. For instance, if there is a certain design constraint (i.e. the device must fit over the legs and not interfere with leg swinging), it sets a limit for the maximum inside width of the device. Once these limits are determined, some designs can be thrown out, because they do not meet these predetermined constraints. Furthermore, developing the architecture for such a system allows the designer to quickly find the critical components of the design and set aside an appropriate amount of time and resources.

In addition, there are certain design requirements that must be addressed.

1. The system must be able to decrease the metabolic energy of walking enough that it justifies designing and building a device. It hardly seems worth the effort to design a system if the efficiency of walking can only be improved by a few percent.
2. Since this device is primarily geared toward walking/hiking, a suitable design requirement would be that the user must be able to hike comfortably in this device and therefore the range of motion of this device should be sufficient so as to not greatly limit the user's activities. It is acceptable to limit some of the user's activities such as rock-climbing. It would not be acceptable if the user could walk at only one speed, or had to take the device off in order to sit down.

The system must also be comfortable enough to wear for extended periods of time. Since it is not uncommon for hikers or military personnel to hike for eight hours a day, the system must be comfortable enough to be used for that period of time. Tissue needs oxygen to live, and will not survive if it is subjected to high pressures for an extended amount of time. Tissue compression and comfort will therefore be heavily weighted in design considerations. It is also advantageous for the system to be lightweight for comfort and portability.

It is useful to consider the extent that the system will change the natural gait of the user. It is unlikely that a system could be developed that both reduces energy consumption in walking and does not alter the look or feel of the user's natural gait. Humans walk so often that the control of each muscle is so finely tuned that it would be nearly impossible to make a system that does not interfere with the user's natural gait. Even making small changes in walking conditions, such as changing from running shoes to hiking boots is noticeable. However, the body can adjust to this in a short period of time.

Additionally, the system should be kept as simple as possible. After examining prior work done with exoskeletons and looking at actuator sizes and battery size, it appears that any device which actively adds power to joints will be expensive and heavy. A powered system goes beyond the goals for such a knee brace and therefore will not be considered. Additionally, a powered system requires relatively high power motors, and substantial energy storage. The system will therefore be a passive device where the knee joint is not actively powered. It is acceptable for small motors or actuators to be used, but they must not be used to power joints.

In order for the system to be easily produced, it must be able to be used by most people without the need for custom molds of their bodies or legs since molds take a significant amount of time to produce and add to the expense. The device should be able to be put on and to be taken off quickly and easily without assistance.

5 PUUMA Architecture

In humans, legs are composed of a lower shank body and an upper thigh body coupled at the knee joint. Leg muscles provide a means for creating a torque at the knee joint which allows the a force to be applied to the torso through the hip socket. Between the time of heel strike and maximum knee flexion, the muscles in the legs must produce a torque on the knee which transmits a force to the torso sufficient enough to decelerate the torso. The muscles in the legs then have to generate a knee torque to accelerate the torso after system apex. While tendons act like springs, it is likely that they store and release only a small fraction of the kinetic energy lost during the WTE. Therefore the leg muscles must produce significant forces and use a substantial amount of metabolic energy during the walking cycle. Fortunately, a simple torsion spring both stores energy and produces a torque. In the walking cycle, there are times where the knee must produce a torque, and there are times where it must be able to rotate freely. Unfortunately, since this can not be accomplished with a standalone spring, an additional mechanism must be implemented.

The simulations in Chapter Three do not take into account walking down a slope. When walking down an incline, the torso is gaining energy. If a person wishes to walk at a constant speed, they must somehow dissipate the energy gained. Since humans have no method of directly converting kinetic energy to heat, the muscles must produce additional forces, which increase energy consumption. Fortunately, it is fairly straightforward to incorporate a brake into the device.

After examining simplified walking models and prior art, it has been determined that for the system to work, the knee brace must have the following properties.

1. It must store the kinetic energy lost during the WTE epoch and release it after the torso has rotated past apex.
2. It must have the ability for the knee to be in a free swing mode.
3. It must have a mechanism that allows the energy gained from walking down a hill to be dissipated.
4. It must be controllable.

The author proposes that the first three can be solved by combining a torsion spring at the knee with a mechanism that can brake/lock the knee. The solution to the control problem will be discussed only briefly in this paper.

There are two primary methods of accomplishing the first requirement. In first method, the spring constant in the knee spring is selected such that the maximum torsion of the spring occurs just as apex is reached. Following apex, the spring then accelerates the torso upward and forward. This method is very similar to the way that humans walk. In unassisted walking, the effective stiffness of the leg is chosen by the body such that the maximum flexing of the knee occurs just at apex. Since the body a limited ability to store the energy, it flexes the muscles in the legs and converts the energy into heat at the expense of added metabolic energy. In the second method, a latching mechanism that has the ability to lock the knee at maximum knee spring torsion is introduced. If a large enough spring constant is selected, the maximum knee spring angle will always occur before system apex. Later, the knee is unlocked thereby converting the energy that would have been lost at heel strike into kinetic energy that propels the torso upward and forward.

Although the first method is more similar to human walking, it is significantly more difficult to implement. In order for the system to decrease the metabolic energy of walking, the system needs a predetermined spring constant, walking speed, and torso mass. If any of these conditions vary, the system will not aid in walking. It is extremely common to walk at different speeds and carry different loads, so this system would require a spring that could vary its spring constant based upon walking speed and load. Humans effectively do this by activating certain muscle fibers, thereby achieving an almost infinite number of spring constants. This is not as straightforward to do in the mechanical world. It is possible to have a few springs in the system, but there would be a limited selection, and the system's performance would suffer if the needed spring constant was not in the limited selection.

The second method described works for a variety of walking speeds and walking loads. Although it does not mimic human walking as closely as the first method, it is more robust and is therefore the preferred choice.

The interface with the human body is another major decision. There are two primary architectures to consider. The first, shown in Figure 5.1, is a system that is similar to existing knee braces, but with the addition of the spring/latch mechanisms. There is no structure that connects a backpack to the device. The second architecture, shown in Figure 5.2, attaches to the shoes of the user, has a skeleton that runs up the sides of the legs, and has a mechanism to support the backpack. If necessary, it could have a bicycle seat for the user to sit on.

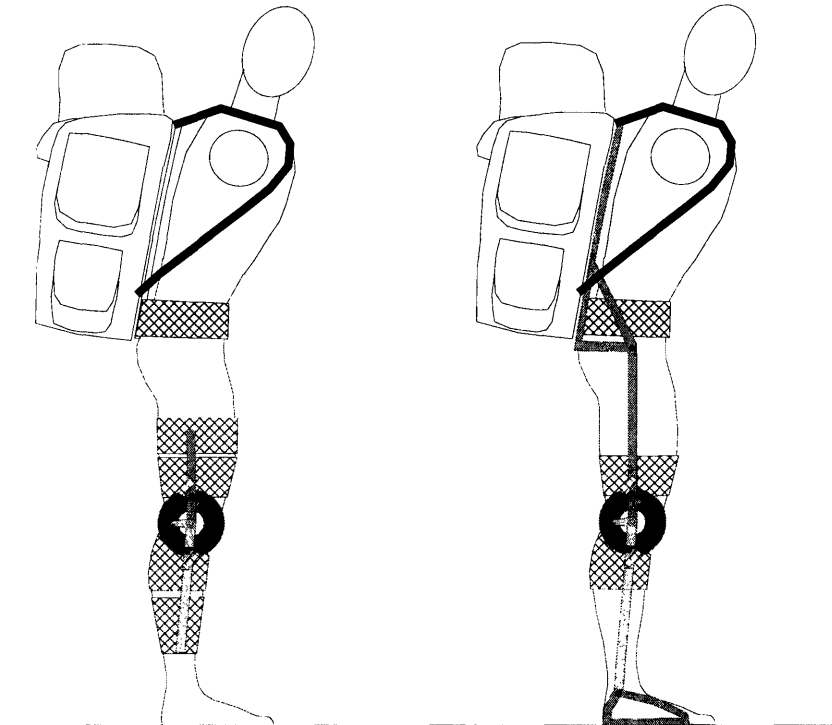

Knee Brace Architecture

Figure 5.1

Exoskeleton Architecture

Figure 5.2

Each architecture has its advantages. Clearly, the first architecture is simpler than the second. The second architecture allows all of the weight of the backpack and the torso to be transferred to the ground through the skeleton rather than through the knee joints. This is particularly important if the user is carrying heavy loads. It also makes it easy to incorporate a seat into the design, if needed.

The knee brace architecture has a few problems, some of which may be a big concern. One problem is that both the weight of the torso and the weight of the backpack is transferred through the knee joints and the feet. Although soldiers and hikers routinely do this for relatively large loads, this could become a concern if they carry even heavier loads for longer periods of time. In addition, the knee brace may slide along the leg and cause chafing or discomfort. Solutions to this problem are discussed in Chapter Six. Tissue compression could be a problem because the torque generated by the spring in the knee has to be transmitted to the body, thus requiring surfaces to press against the back of leg. However, simple calculations shown in Chapter Six indicate that this should not be a problem.

These two architectures are suited for slightly different applications. The first architecture would be more suitable for the elderly, or for those carrying relatively lighter loads, while the second is more suitable for the military or those who want to carry much heavier loads.

Although the second architecture can theoretically provide better performance, its additional complexity makes it unattractive for a system that has not yet been developed. Since there is currently no practical system

that decreases the energy consumption in human walking, any system that does so will be a noticeable improvement, even if it has limitations. For that reason the knee brace architecture is the preferred choice.

Another important architectural decision is the location of the knee spring. There are two main designs that must be considered. In the first design, the knee springs are on both the inside and the outside of the leg. This results in a balanced system, but at the expense of additional components, and the risk of collision with the inside of the other leg. In the second design, the knee spring is located only on the outside of the leg. This requires fewer components and eliminates any problems with interference, but results in an unbalanced system. Additionally, the knee spring would have to be twice as stiff and the latching mechanism would have to hold twice the torque.

An unbalanced system could potentially cause many problems with twisting which could lead to discomfort. To avoid problems that may arise from an unbalanced system, the balanced architecture is the preferred choice. Although there are more individual components to the system, most are duplicates and do not require additional design. It is felt that eliminating the potential risk of an unbalanced system justifies the cost and the complexity of having a system with additional components. The system can always be simplified by having only an outside spring once more information is obtained from a prototype.

6 PUUMA Design

6.1 Spring Design

Springs are made out of a variety of materials depending on the application. It is not uncommon for springs to be made out of plastic, metal, rubber, and even composite materials. All materials have their pros and cons. Plastic springs may have a lower energy storage to weight ratio compared to a carbon fiber spring, but they are less expensive and easier to manufacture. The energy storage to weight ratio, the cost, size limitations, durability and the ease of manufacturability are all attributes that must be considered in the design of the spring.

Certain materials are more suitable for energy storage than others. Almost all materials stretch to some degree before they break. Rubber stretches a considerable amount while ceramic materials tend to fracture at low elongation. For a given force, materials with a higher Young's modulus will stretch less than materials with a lower Young's modulus. The energy storage of a material is equal to the area under the stress-strain curve (shown in Figure 6.1) before yielding.[2] It can be shown that the energy storage in a material is

$$(\sigma_y^2)/(2E)$$

If we divide by the density, the energy storage per weight is

$$(\sigma_y^2)/(2E\rho)$$

These equations show that it is beneficial to have a material that has a low density, high yield strength, and low Young's modulus. Material properties and the energy density for various materials are shown in Table 6.1. [32]

Material	Tensile Strength (Pa)	Tensile Modulus (Pa)	Density	Energy per Kg (J)
Kevlar/Epoxy	1.10E+09	6.36E+10	1350	7046
Carbon Fiber/Epoxy	1.73E+09	1.42E+11	1590	6628
Fiberglass/epoxy	8.70E+08	3.95E+10	1810	5293
ASTM A228 steel (music wire)	2.20E+09	2.10E+11	7800	1477
7076 T61 Al	4.70E+08	6.70E+10	2800	589
6061 T6 Al	2.76E+08	6.90E+10	2700	204

Table 6.1

A comparison of the energy storage versus mass is shown for various materials in Figure 6.2. It should be noted that although Kevlar, carbon fiber, and fiberglass individually have a very high tensile strength, their tensile strength is essentially decreased by a factor of two because the composite must be mixed with an epoxy, which has a very low tensile strength in comparison with the composites. The tensile strength is further reduced if the composite is woven since half of cross section is taken up by fibers that run orthogonally to the direction the force is applied. It should also be noted that there are hundreds of different kinds of carbon fiber

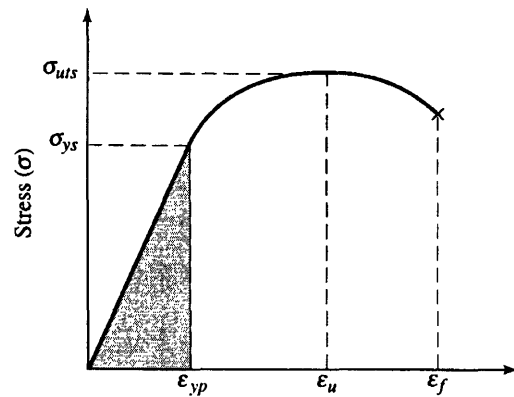

Figure 6.1

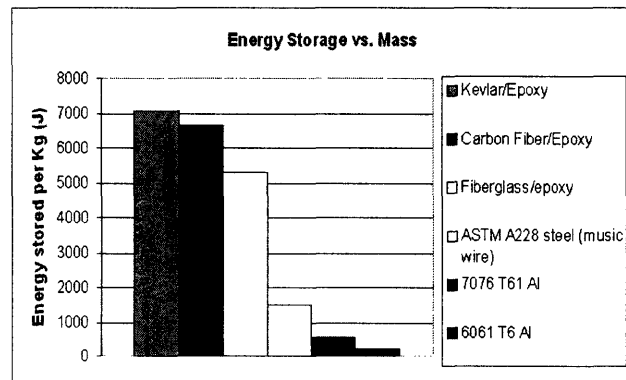

Figure 6.2

styles and finding reliable data for the carbon fiber proved to be somewhat difficult.

Figure 6.2 shows that the composite materials have a significant advantage over materials such as steel. Unlike metals, composites do not undergo a plastic regime. Steel typically has an ultimate tensile strength that is approximately 40% higher than its yield strength. Metals do not completely spring back after they have gone into the plastic regime so the ultimate tensile strength can not be used. In addition, composites tend to have a lower Young's modulus which causes the material to stretch more and therefore allows them to store more energy. Lastly, the densities of composites are a fifth that of steel, which gives composites another big advantage.

Interestingly enough, Kevlar does not have the highest energy storage per weight of any material. Some materials, such as elastomers, have a low modulus of elasticity and can stretch upwards of 800% before breaking. This results in an energy storage density that is significantly larger than Kevlar. However, this is not without disadvantages. These elastomers are similar to metals in that they do undergo a plastic regime. Although they can be stretched 800% before breaking, many go into their plastic regime at a fraction of their maximum elongation. In addition, in order to achieve these high energy densities, the material must be stretched significantly more than Kevlar. Since we are interested in roughly 40-80 degrees of spring rotation, the spring must have a different geometry than the curved cantilever spring to maximize the energy density. Additionally, since elastomers have a Young's modulus many orders of magnitude lower than composites, a different geometry is needed to achieve the appropriate spring constant. A suitable geometry is described later.

Although elastomers appear to be a very good choice or a spring, they do suffer from wear and creep problems that are not as large an issue in composite springs. On the other hand, many elastomers can be cast, which offers a large reduction in cost versus manufacturing with composites.

Aside from elastomers, Kevlar seems to be the best choice for energy storage versus weight. Kevlar and carbon fiber have roughly 4.5 times the energy density of music wire, the steel most commonly used in springs. High grade aluminum alloys are slightly better than the music wire, but are extremely expensive and are still inferior when compared to composites.

Surprisingly, although Kevlar appears to be better than carbon fiber, it is seldom used for springs. The author proposes a few reasons why this is the case. Kevlar is significantly more difficult to work with than carbon fiber. Compared with carbon fiber, Kevlar is substantially more difficult to cut, and requires special scissors to do so. Kevlar also does not machine well at all. Sanding it results in a very rough torn surface, whereas carbon fiber sands very easily. Secondly, Kevlar is simply not used as much as carbon fiber, and there are fewer companies who do work with Kevlar. The low demand for Kevlar components results in high prices. Since energy storage versus weight is not a huge concern for most companies, they are willing to sacrifice some performance to save money.

Components that are made of composite materials are made in layers. This makes it more straightforward to manufacture a prototype if tooling is limited. Composite materials are typically woven into a fabric which allows individual layers to be easily cut. Epoxy is impregnated in each layer, and each layer is then pressed together at a high pressures. Vacuum bagging, although somewhat expensive, is the preferred method for compressing the layers. Prototypes of components can be constructed by using alternate methods of compression, but usually have a higher ratio of epoxy than desired which adds excess weight. For most prototypes, the ease of manufacturability makes up for the increase in weight.

The shape of the spring is extremely important to consider. This is broken down into two categories, the general shape of the spring and the optimized shape of the spring. Helical, torsion, and cantilever springs are among the most common spring shapes, although one can also store energy in a material simply from axial loading.

One important consideration in the spring design is the torque profile. Optimally, the spring would provide a restoring torque equal to the torque generated on the knee. To hold body weight, the torque generated by the knee is equal to $mg\ell \sin(\theta)$, where ℓ is the length of the thigh and θ is the knee angle. The spring should therefore generate this torque profile, or a torque profile close to this. Helical springs provide a force profile of

$f = kx$, and a cam would be required to create the linear force into torque. Torsion springs create a torque profile of $f = k\theta$. For small values of θ , $\sin(\theta)$ is approximately equal to θ , so a torsion spring provides a torque profile that is within a few percent of the desired torque profile.

A helical spring could be used in conjunction with a simple cam to create the required torque profile, but this is not as an attractive solution for a few reasons. Adding a cam mechanism adds to the complexity of the system and also makes it more difficult to fit the spring in a compact area. Additionally, a helical spring is not a suitable shape to make out of composite materials. A curved cantilever spring is significantly easier to manufacture, it is easy to fit in a small area, and has almost exactly the desired torque profile.

One alternative to the cantilever spring is a spring created by wrapping an elastomeric material around a mandrel. Figure 6.3 shows a mandrel design for knee flexion angles of 0, 40° and 80°. It should be noted that

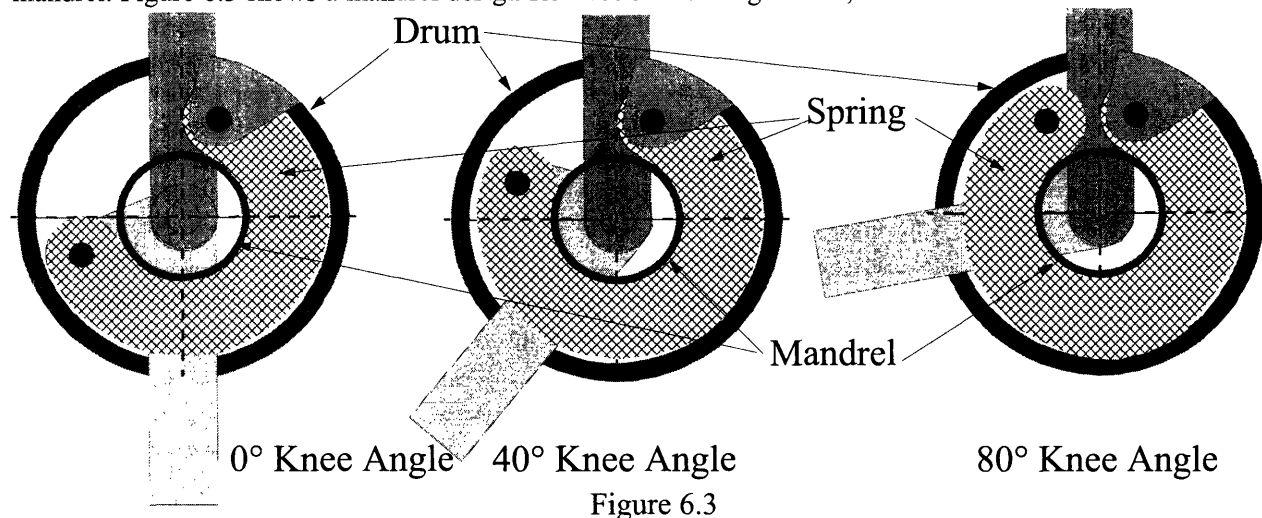

the the spring must rotate more than 45 degrees only in extreme conditions.

This geometry results in a stress distribution that is more uniform than that of a curved cantilever spring. For the curved cantilever geometry, one side is in compression and one side is in tension. There is almost no stress in the center of the cross section and therefore does not contribute to the total stored energy. If the material is wrapped around a mandrel, the whole cross section is in tension. Although the stress profile changes with the radius is it much more uniform than that of the cantilever spring and therefore this geometry is more efficient at storing energy. For this reason, a mandrel spring is more attractive than a cantilever spring. Its main drawback is that because spring that must be able to rotate at least 40 degrees without yielding, the material would have to be able to stretch upwards of 20 percent and still remain in its elastic region. This is towards the upper limit for elastomers with a high yield strength. Although a solution can be found by wrapping the elastomer twice around the mandrel, this significantly adds to the complexity of the spring and is not a plausible solution. In addition, there will be some energy loss due to friction between the elastomer and the mandrel. For this thesis, a curved cantilever spring was selected because of time constraints.

The detailed design of the spring is quite important when it comes to weight optimization. The spring has to be able to store the required energy without breaking, and also have the correct spring constant. Although there are many formulas that allow for such calculations, an easier and more accurate method is to use a finite element analysis program.

6.1.1 Spring Finite Element Analysis

Simulations show that the spring needs to be able to rotate at least 40 degrees and the two springs should have a combined spring constant of roughly 400 N-M/radian. Initial estimates based on a simple cantilever spring formulas suggest that the thickness of the spring should be around 10 mm.



Figure 6.4

A finite element analysis of the preliminary spring design was conducted. When the spring was subjected to the maximum torque, the FEA predicted that the maximum stresses exceeded that allowable for Kevlar, and the spring constant was not high enough. The thickness of the spring was gradually increased until the maximum stress did not exceed the allowable stress. Unfortunately, this resulted in a spring constant that was still too high. To solve this problem, the thickness of the spring was reduced in areas that had a low stress concentration until the combined spring constant of 425 N-M/radian was reached. The stress concentration at maxi-

mum compression can be seen in the Figure 6.4.

The FEA shows the stress concentration when the spring is subjected to an 90 N-M torque. Although theory would suggest that the highest stress intensity would occur at the middle of the spring, this simulation predicts otherwise. This is in fact not true. This finite element analysis used restraints which do not accurately reflect the actual restraints that the spring would experience. It is for this reason that the maximum stress does not appear to be in the middle. Although this simulation does not predict exactly what the spring is experiencing, it at least gives a starting point for the spring design and is still better than doing calculations manually.

Once again, much of the detailed design can be done based upon first principles. When the spring is at maximum compression, the highest stress intensity occurs at the middle of the cantilever. The weight of the spring can be reduced by reducing the thickness of the sections with a lower stress intensity. Optimally, the spring would have a uniform stress intensity throughout. Figure 6.5 shows that the stress is highest at the edges of the spring. This is not surprising because beam bending theory predicts that the stress will be highest at the edges and almost zero at the center.

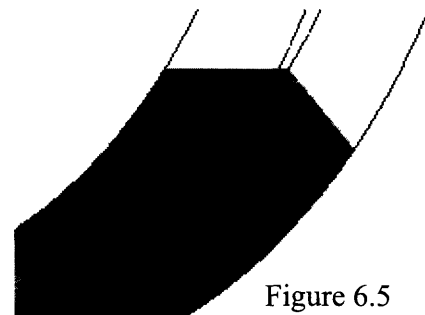

Figure 6.5

Theoretically, the spring's weight could be further reduced if the spring's cross section resembled an hour glass. Although this would reduce the weight of the spring, the more complicated geometry would make the spring significantly more difficult to manufacture. If the advertised density of 1350 kg/m^3 for a Kevlar/epoxy mixture is used, then the theoretically weight of the spring is approximately 0.22 Kg. It is difficult to justify the additional manufacturing difficulties involved in creating an hour glass cross section so shave a few ounces from the weight from the spring considering the overall weight of the system.

The manufacturability of the spring is an extremely important consideration in its design. Not only does the

spring have to be lightweight, store the required energy and have a certain spring constant, but it also must be able to be manufactured relatively easily. It is extremely easy to design a component on paper that is difficult to manufacture.

6.1.2 Composite Spring Prototype

A prototype for the knee spring was manufactured by cutting Kevlar into strips, applying epoxy to all surfaces, compressing the strips in a jig, and then allowing the epoxy to dry. Nine strips of Kevlar fabric, each approximately 19 mm wide and 1 m long were cut and a light coat of epoxy was applied to both sides. The strips were then wrapped around two 6.35 mm pins 210 mm apart. The strips were sewn together to prevent unraveling during the manufacturing process. The bundle of strips was then put in a jig and the arms of the jig were clamped together. The spring was allowed to dry and was then taken out of the jig. A second coat of epoxy was then applied to the edges to improve the machinability of the spring. After the second coat was allowed to dry, the spring was sanded and a coat of paint was applied to the spring to protect it from deteriorating under sunlight. The prototype of the spring is shown in Figure 6.6.

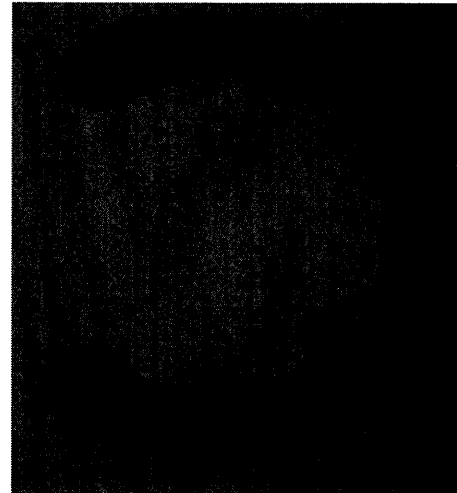

Figure 6.6

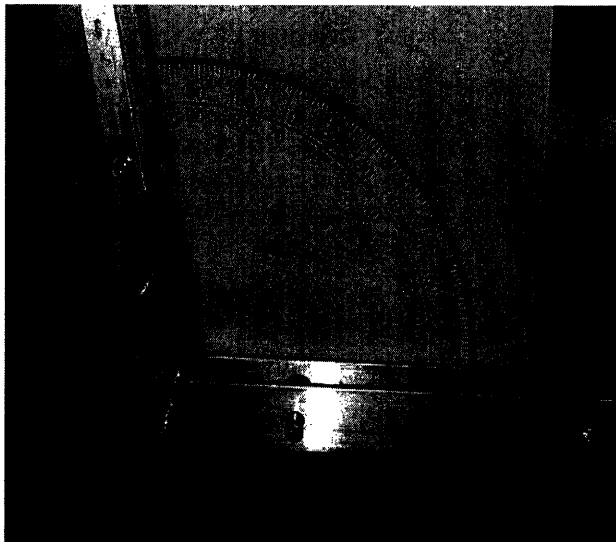

Figure 6.7

To get an understanding of the actual performance of the spring, a jig was created to measure the spring constant. Two 6.35 mm holes were drilled 48 mm apart into each of four aluminum bars, which corresponds to the approximate center of the spring. The aluminum bars were screwed into wooden spacers to solidify the jig and to maintain a consistent spacing between the bars. Three 6.35 mm steel rods were used for the pivot axle and the spring mounting pins. The jig was clamped to a table and a protractor was placed behind the jig so that the spring angle could be measured. A picture of the jig can be seen in Figure 6.7.

A RiteWeight G-SA-TT-FS18 fishing scale was attached 395 mm from the axle. The force exerted on the scale was recorded at five degree increments from 0 to 41 degrees. The spring snapped at a value of approximately 44 degrees. The recorded measurements can be

seen below.

Angle (degrees)	Normalized	Angle in radians	Force (lbs)	Applied Force (N)	Torque (nM)
69.0	0.0	0.0	0.0	0.0	0.0
70.0	1.0	0.0	0.4	2.0	0.8
75.0	6.0	0.1	2.9	12.8	5.0
80.0	11.0	0.2	6.0	26.7	10.5
85.0	16.0	0.3	8.7	38.8	15.2
90.0	21.0	0.4	11.7	52.1	20.5
95.0	26.0	0.5	15.5	69.0	27.2
100.0	31.0	0.5	18.0	80.2	31.5
105.0	36.0	0.6	20.0	89.1	35.0
110.0	41.0	0.7	22.0	98.0	38.6

Table 6.2

Shown in Figure 6.8 is a graph of the torque on the spring versus the spring torsion angle. As expected, the spring constant is linear, although the measured spring constant of 56.3 N-M/radian is significantly lower than the required value of 200 N-M/radian.

There are a few reasons why the measured value could vary from the theoretical value. The spring was manufactured before the finite element analysis could be completed and the stress concentrations shown above are representative of a slightly different geometry. Another potential reason is due to the varieties of Kevlar.

All of the material properties and simulations shown above correlate to a mixture of Kevlar 49 and epoxy. The material properties for the Kevlar used in the manufactured spring could not be obtained. It is very possible that the spring was made from Kevlar 29, which has material properties that different than Kevlar 49. The Kevlar 49 has a Young's modulus which is almost two times larger than the Young's modulus of Kevlar 29. This factor of two may be one reason that the measured spring constant is significantly less than the theoretical value.

The weave of the Kevlar is another important consideration. The Kevlar used had half of its fibers running in one direction and half of its fibers running orthogonally. This means that for a given cross sectional area, only half of the area is contributing to the strength. This greatly reduces the stiffness of the spring.

Although the measured spring properties were significantly different from the theoretical simulations, creating the spring did provide a great deal of insight. One significant finding is the location of the stress fracture,

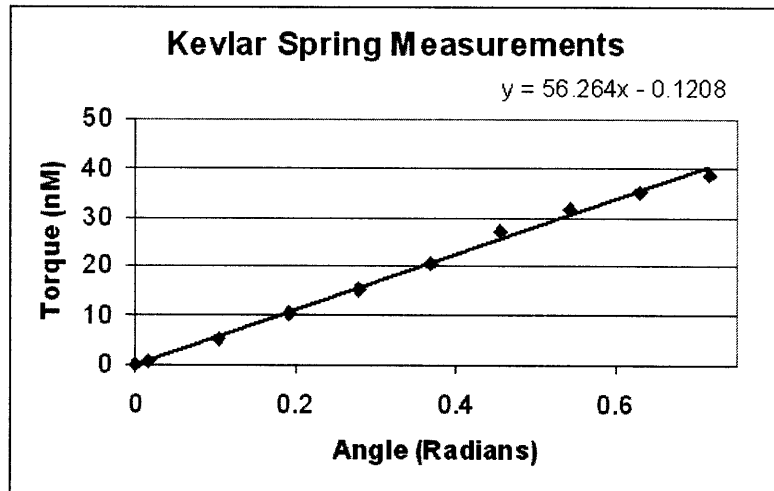

Figure 6.8

shown in Figure 6.9, which is almost exactly in the middle of the spring.

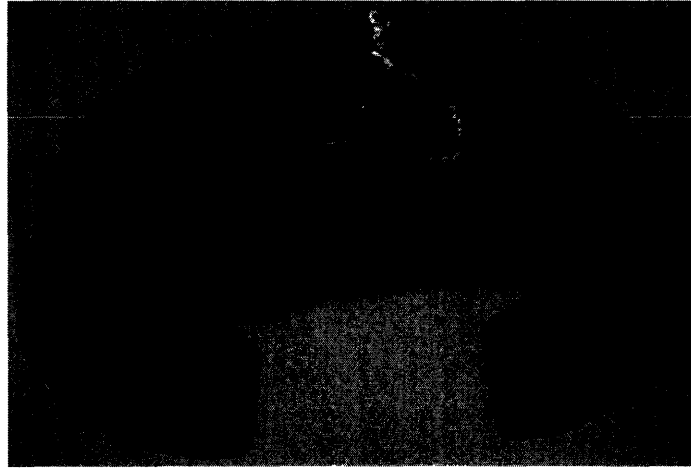

Figure 6.9

6.2 Latching/Braking Mechanism

The mechanism that latches/brakes the knee at maximum flexion is critical to the success of this device. It must be extremely reliable, relatively quiet, low power, and also thin enough so that it does not interfere with the leg swing. A simplified model predicts that it must be able to hold a torque of at least 110 N-M per drum. Additionally, it should be relatively compact. The knee spring will be enclosed in an aluminum drum 127 mm in diameter with 6.34 mm walls. This size was chosen based upon the size of the knee and the availability of the metal. The latching/braking mechanism must be able to handle the following four modes required for walking.

1. A latched, or frozen mode, that locks the knee at maximum spring flexion. This will occur shortly after heel strike.
2. An energy capture mode, where the thigh and shank are coupled to the torsion spring.
3. A free mode, where the spring is not engaged, and the knee joint is allowed to bend freely.
4. A braking mode that allows energy to be dissipated when the knee is being bent. This is necessary in order to walk down inclines at low metabolic energy.

The system has to be able to transition between these modes quickly and at a low power. Additionally, the knee must be able to be latched at any angle, not one which is predefined.

Ratchets and brakes have been around for hundreds of years, and it is therefore useful to look at these mechanism for ideas. The first design to consider is a simple ratchet mechanism. This suffers from a few problems. In order to hold the required torque, there is a substantial amount of force on the teeth of the ratchet. With a 127 mm drum, there is 1800 Newtons of force on the teeth. Although teeth could be designed to handle this force, releasing the ratchet under such a load causes all of the force to be transmitted to the tips of the teeth. This produces extremely large forces on the teeth which may result in wear problems. Additionally, releasing the pawls requires a substantial amount of power. If the teeth are 6 mm deep and have a coefficient of friction of 0.2, and there is a force of 1800 Newtons on the teeth, releasing the teeth requires roughly 2.2 joules. If the ratchet has to be released in 50 ms, this requires a motor that can produce roughly 45 watts.

The biggest limitation of the ratchet is that it is not infinitely variable. The teeth on the ratchet could be made large enough to solve any strength issues, but this greatly limits the resolution of the latch. It is possible that a another verniered ratchet could be used to increase the resolution, but this adds complexity and still does not give the latch enough resolution. In order for smooth operation at any speed, it is critical that the knee can be locked at any angle, and it is not acceptable for the knee to be locked at certain angles, even if the gradations are relatively small. Finally, a ratcheting mechanism provides no method to dissipate the additional energy

gained from walking down a slope. A separate breaking mechanism would have to be added. The limitations of the ratchet and the need for an additional braking mechanism suggest that this is not an effective way to solve the required problems and that better solutions need to be discovered.

Most infinitely variable latching mechanisms use friction to provide a holding force. Although brakes in cars use friction to primarily to dissipate energy, they also have the ability to lock the wheel. In this system, the latching mechanism will only be activated and change modes when the knee is stationary.

The primary problem that occurs in holding a large torque with friction is the limitation of material's coefficient of friction. Few materials with suitable wear characteristics have a coefficient that is larger than 0.3. Various coefficients of friction can be seen in Table 6.3.

Material	Advertised coefficient of Friction on steel	Measured coefficient of friction on steel
Steel	0.20	0.18
Aluminum	0.25	0.20
Brake lining 1	0.40	0.23
Brake lining 2	0.50	0.25
Rubber	0.90	0.50

Table 6.3

Note that there is a significant discrepancy between the advertised coefficient of friction and the author's measurements. The reason for the discrepancy is unknown. Although the exotic materials used in the brake linings do not seem to live up to their advertised specification, they are significantly better than aluminum and thus justify the additional complexity and expense of coating the outside of the drum with a brake lining material.

If a friction plate was used to hold the 110 N-M of torque, it would have to exert a force of upwards of 7200 Newtons on the drum, even with the exotic brake lining material. This is not practical to do with electric actuators because they would require substantial gearing which is expensive, or a threaded screw, which is very inefficient. Additionally, the actuator would have to provide a substantial force and would therefore require a relatively large amount of power. If the actuator had to provide 7200 Newtons of force over a range of 2 mm, it would require on the order of 9 joules. If the knee had to be released in 50 ms, this would require a motor that could output 180 watts. Lastly, the drum would have to be quite strong to support a load of 7200 Newtons, which would add the weight of the system.

Electromagnets are commonly used to provide large holding forces, but they require extremely small gap separations and their performance drastically suffers for even very small gaps. Hydraulic or pneumatic actuators could be used, but the power requirements would be the same, and even if this problem could be solved, the drum and axle are still not likely to be able to withstand such force.

Although the frictional force is not dependent on the contact surface area, it is dependent on the number of contact surfaces. The most famous example of this is the popular Bendix coaster brakes typically found on some older bicycles. Instead of only having one contact surface, the Bendix brake utilizes dozens of friction surfaces, therefore multiplying the effective coefficient of friction. A similar idea could be used in this latching mechanism, but it adds a great deal of complexity, and even a factor of twenty does not decrease the power requirements by enough to be practical.

Drum brakes that generate an incredibly large clamping force work on the principle of self actuation. Much like a wedge, the more the brake pads grasp, the more they push against the inside of the drum. This works very well to brake or hold a system, but it is not very convenient to release. In automobiles, this problem is solved by adding carefully placed springs and other mechanisms inside the brake. Although this would be a potential solution, the complexity of the release mechanism, the size, and the activation time make it an unattractive solution. A simplified diagram of a drum brake is shown to in Figure 6.10. [31]

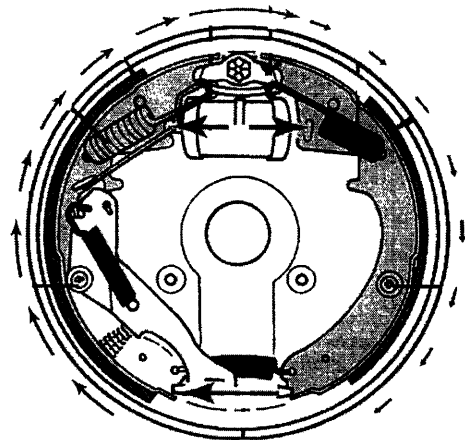

Figure 6.10

In order to decrease the power and force requirements of the actuator enough to be useful, a latching/braking mechanism that has an extremely large mechanical advantage will have to be found. One of the best ways to do this is to use the capstan effect.

The capstan effect has been well known by sailors for thousands of years. Large boats can be secured to the dock simply by taking a rope and wrapping it around a post a few times before securing the end. Ideally, the holding force on the rope goes as $F = F_{hold} e^{(\mu \theta)}$. This is one of the few principles that allows an exponential mechanical advantage to be generated.

This exponential holding force can be used to solve the problem. If a strong cable is wrapped around the drum, fixed to the thigh strut at one end, attached to an actuator at the other end, the drum can be frozen by applying a significantly smaller actuation force compared with other braking schemes. Since the wire rope is bent around the drum, it has a tendency to spring back naturally. Unlike the drum brake, the capstan brake does not require any additional springs. If the drum is coated with brake lining material having a coefficient of friction of 0.25, 7 Newtons of actuation force can hold the full 110 N-M or torque. Additionally, since the actuator just has to take in the slack, it does not have to travel over a great distance. If the actuator moves 6 mm in 50 ms, it uses only 0.04 joules of energy and requires a motor power of only one watt. This method of locking the knee uses two orders of magnitude less energy than either the ratchet or the disc brake.

A simple jig was used to test this principle. An aluminum drum 50 mm in diameter was mounted on an axle, and a handle was attached to the drum. Various weights were suspended from one end of the wire and the other end was securely clamped to the table. A fishing scale was used to measure the force exerted on the handle before the drum started to slip. A picture of the jig is shown in Figure 6.11, and the results are shown in Figure 6.12.

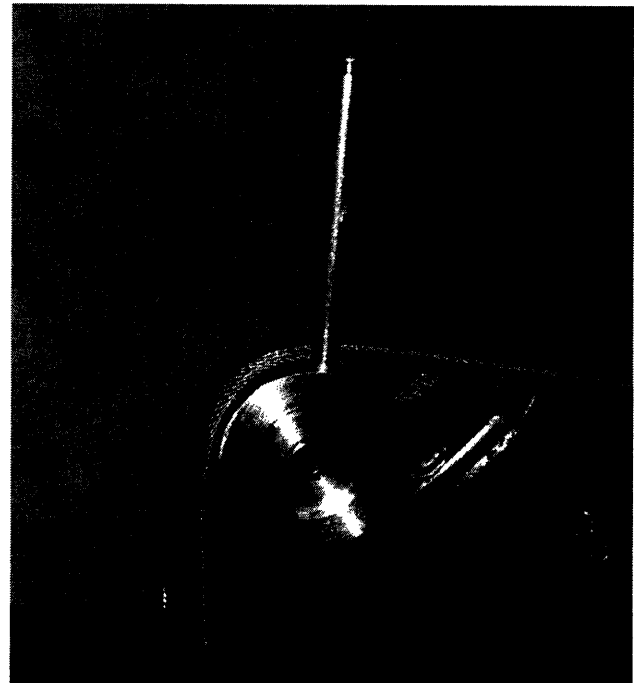

Figure 6.11

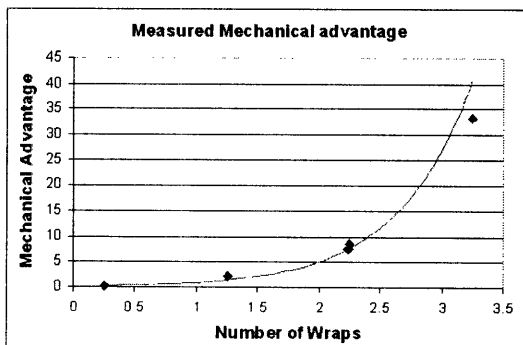

Figure 6.12

In an attempt to increase the coefficient of friction of the drum, sections of brake lining were glued to a 127 mm drum. The drum was clamped in a vice, and a weight was hung from the end. The force needed to hold the weight was recorded and the results were plotted. The results can be seen in Figure 6.13.

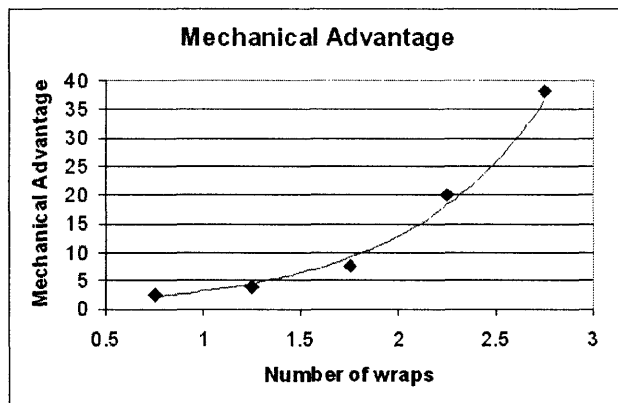

Figure 6.13

Although the test results did not predict the exact mechanical advantage, it did show that the mechanical advantage did have an exponential relationship with the number of wraps and the capstan effect does provide an effect way to hold a large amount of torque with a very small force.

Two sets of wire ropes must be wrapped around the drum since the drum must be dynamically coupled to both the thigh and the shank. One wire rope couples the drum to the thigh while the other couples the drum to the shank. With four wraps of 1.6 mm wire rope, the minimum drum width is 15 mm. Since wire rope 1.6 mm in diameter has a breaking strength of 2200 Newtons, two ropes at one end of each set of wires are needed in order to allow for safety margin. The additional section of rope can be jointed to the main section of wire rope with a ferrule. This makes total width of the drum roughly 18.3 mm which should be thin enough to provide adequate clearance between the legs.

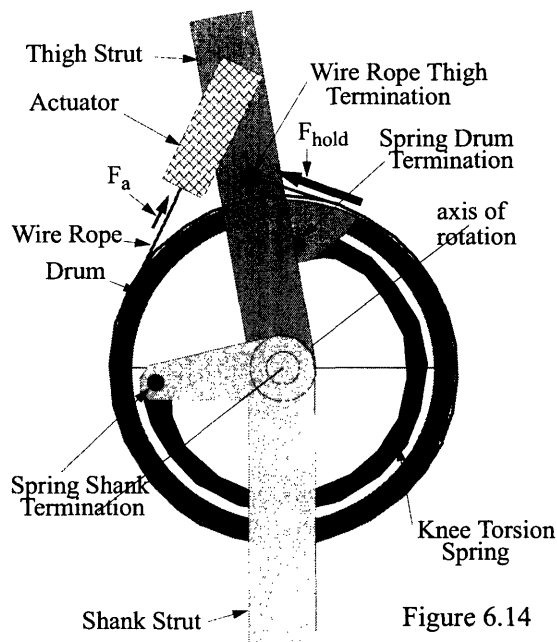

Figure 6.14

Figure 6.14 shows the proposed braking/latching mechanism. One end of the torsion spring is connected to the shank and the other is connected to the drum. If it is desired to store energy in the spring by rotating the thigh counter clockwise, the actuator can be designed to provides a force of 13 Newtons. The capstan's multiplicative affect results in a F_{hold} of approximately 7,000 Newtons, substantially greater than the breaking strength of the wire rope. The other end of the wire rope is terminated at the wire rope thigh termination, so the thigh is effectively coupled to the drum provided that the wire does not break. This effectively couples the spring to the thigh. The second wire rope is wrapped around the drum in the opposite direction which allows the drum to be coupled to the shank. This provides a mechanism for mechanically freezing the knee angle at its maximum torsion. This configuration also allows for energy to be dissipated when walking downhill if the activation force can be controlled. If the torque on the knee is greater than the holding torque, the knee will rotate and energy

will be dissipated as heat. The build up of heat is not an issue because the outside of the drum will be lined with a brake lining material, which is specifically designed for this application.

If the thickness of the latching mechanism is important, a V groove could be cut into the drum. This would effectively increase the coefficient of friction and therefore require fewer wraps, but it may cause the wire rope to wear more rapidly. One problem with the capstan principle is that in its normal mode, the wire rope must be wrapped around the drum such that the thickness of the drum must increase as the number of wraps increases. This issue could be alleviated if the wire rope was tapered so that the thicker section was attached to ground and the thin section was attached to the actuator.

6.3 Interface With Human Body

The interface with the human body is one of the most important items to consider. There are certain physical limitations which must be addressed. In particular, a solution as to how to attach the device to the leg without any tissue compression and discomfort must be found. This section will describe the most important problems that need to be solved and discuss potential solutions. In particular, it will address tissue compression, knee extension issues, ways to keep the device in place, the size of the device and clearance issues, and human adaptability.

6.3.1 Tissue Compression

In order for tissue to survive, blood must be able to flow into it on a regular basis. If sufficient pressure is applied to the tissue, capillary blood flow ceases. Without blood flow for an extended period of time, the tissue will undergo necrosis. This is a major problem in paraplegics who can not feel when the tissue is being compressed. The knee brace must be attached to the leg in such a manner that prevents the user from damaging tissue.

The flow of blood is the limiting factor with tissue compression issues. Blood flow is a function of the pressure applied to the tissue and the duration that pressure is applied. Blood is able to flow into tissue relatively quickly, and the tissue can therefore replenish its blood supply fairly quickly. Tissue is therefore able to withstand a surprisingly large amount of pressure, providing that the pressure is not constant. For instance, if a person stands on the balls of his feet, there is a large amount of pressure acting on the tissue on the order of 140 kPa. If the person is not allowed to shift his weight, he will begin to feel a great deal of pain and will eventually have to stop, or risk damaging the tissue. But if he is able to shift his weight slightly, and alternate between standing on one each foot, he will be able to stand without discomfort for a long period of time. If pressure on the tissue becomes high, it is very important to provide periods of time when it is not under great pressure. It should be noted that the maximum steady state pressure is only about 1.7 kPa and it is unlikely that the pressure can be reduced to that level. Since the pressure is not applied all the time, there is no need to reduce the pressure to anywhere close to that level.

If the total torso mass is 100 Kg, and the knee is bent at a 25 degree angle, the knee must produce 170 N-M of torque in order to stand on one bent leg. Under normal walking conditions, the torque requirements are not this high. If there is padding along both the back of the thigh and the back of the shank, the force can be approximated as acting at the center of padding. It is not realistically possible to put padding over the entire back of the thigh, but knee braces such as the DonJoy TROM (shown in Figure 6.15) shows that current knee braces provide substantial padding. [35]

Assuming that the padding is 200 mm long, and the center of the padding is 150 mm from axis of rotation of the knee, this translates into an average force of 1135 Newtons on the upper leg. If the padding is 100 mm wide, this results in an average pressure of 54 kPa on the thigh. Although this pressure is substantial, is not an unreasonable amount considering that it will only be applied for a small fraction of the gait cycle. Pressure on the lower leg is also not an issue for the same reasons. Additionally, these torques and forces are assuming that the human is not using his muscles to assist.

Rubbing is just as important to discuss as tissue compression. Many rubbing problems can be solved by putting a sock between the padding and the skin, and also by adding preventative measures that



Figure 6.15

limit the device from sliding.

6.3.2 Hyperextension Stop

One extremely important limitation to consider is the range of motion of the knee. In particular, the knee joint is able to bend in one direction but cannot bend in the other direction without a substantial amount of discomfort. If the knee brace can produce upwards of 220 N-M of torque, it becomes very easy to seriously damage the knee if proper precautions are not taken into consideration.

Fortunately, these precautions are easy to integrate into the design. A mechanical stop will have to be included in the design of the brace so that the brace can bend in only one direction. If anything goes wrong with the system, the large forces will be exerted on the mechanical stop rather than the ligaments in the knee.

6.3.3 Brace Positioning

Another issue to consider is how much the brace will move around when the person is walking. This problem has been solved by most (but not all) companies who design knee braces. One would expect that braces that have a substantial amount of straps and padding are fairly secure to the leg, whereas braces that have less may shift or slide. There are at least two immediate solutions to this problem. One involves attaching a small strut from the lower part of the leg brace to the shoe, and the other involves attaching a belt from the top of the brace to the human body. The later approach would be similar to suspenders. They could either be attached to the backpack, around the shoulders or to a belt. While the specifics of such solutions must be worked out later, the problem of preventing the knee brace from sliding at least appears to be solvable.

6.3.4 Critical Dimensions

The size and dimensions of the device is an important consideration. In particular, any leg clearance issues need to be worked out. The outside width of the device, although less of a concern, should also be discussed. Studies done on the preferred step width in human walking have shown that the average step width was $0.13L$, where L is the length of the leg. [15] For a person with a leg length of 0.91 meters, this corresponds to a step width of around 125 mm. This translates into an inside knee separation of around 65 mm. If the inside of each knee brace can be limited to 26 mm, this should provide enough clearance for the legs to swing.

It should be noted that humans chose their preferred step width to minimize metabolic costs. [15] If the device works as advertised, then the human body should not mind walking at a slightly larger step width. The next section will discuss human's ability to adapt to changes in their walking gait, but it is reasonable to assume that it is beneficial to try to keep the walking gait as close as possible to normal walking.

6.3.5 Human Adaptability

Humans can adapt to changes extremely quickly. Changes in footwear can have a drastic affect on the walking gait, but humans still appear to walk naturally regardless of whether they are in sandals or high heel shoes. Humans can even adapt to more severe changes in the walking gait providing they have some help (braces, prosthetics), such as the loss of a certain muscle function to the loss of a limb. Based upon the author's personal experience, human's ability to adapt is sufficient even with significant changes to their gait.

Although this knee brace system would initially feel odd to walk in since it changes the force requirements of certain muscle groups, it is hoped that a person would be able to learn quickly how to walk with such a device.

6.4 Actuator

The next section describes the requirements of the actuator that applies tension to the wire and mentions some of the advantages and disadvantages of certain designs. Particular attention is spent on the power requirements of the actuator, the life of the actuator and the simplicity of the design.

The section above briefly gave an estimate for the power needed to lock the drum using the capstan principle. Tests have shown that as soon as there is sufficient tension in the wire, the drum is effectively locked. The

needed stroke of the actuator is therefore quite small. A stroke of 6 mm is sufficient to allow the wire to be under tension, or have slack so the drum can rotate. Although the 7 Newtons mentioned above is theoretically possible, it does not allow for any safety margin. A safety factor of two will assure that the drum never slips and will only require an actuator force of only 14 Newtons. Based upon measured walking cycles, an actuator time of 50 ms should be sufficiently fast to lock the drum when needed. These numbers correspond to a power requirement of 1.7 W, but do not account for any inefficiencies due to friction in the actuator.

There are certain features that would be beneficial to include in the design of the actuator. In particular, it would be very useful to know both the position of the end of the wire, and also the force that it is being applied. Although electronic circuitry could be designed to measure the current draw and the voltage across the motor, a method that uses feedback control would be more beneficial. Although feedback control requires a way to measure the force and the displacement of the end of the wire, it allows the both the force and the distance to be controlled very accurately. The benefit of accurately controlling the force applied by the actuator is sufficient to justify the additional complexity involved in feedback control.

Although it is true that the 1.7 W mentioned above is a good estimate for the power requirements needed for actuation, it does not include the power needed to keep the drum locked. The ability for the actuator to be back driven should also be an important consideration in the architecture. Since an actuator that can be easily back driven also requires a substantial amount of power to hold the load, the actuator should not be able to be easily back driven. For that reason, solenoids are not a good choice for an actuator because they can be back driven very easily.

The lifetime of the actuator is also extremely important to consider. If an average step length is 0.81 meters, the actuator would have to go through almost 6000 cycles in a 5 km walk. If we take a conservative estimate and say that the user would walk 5 km a day with this device, it translates into roughly 2.2 million cycles each year. The actuator therefore has to have a very long life span. Certain types of actuators, such as brushless motors, are more suitable than brushed motors for this application.

The cost of the actuator should also be taken into consideration. Most motors can be purchased relatively inexpensively, although a gear head motor is typically rather expensive. Expensive components, such as gear heads, ball screws, and linear motors will be used only if absolutely necessary. Although brushless motors are significantly more expensive and require more electronics to control, they suffer none of the wear problems that brushed motors have. Since a motor failure would be very inconvenient for the user, the benefits of a brushless motor justify the additional cost.

There are a few ways to convert rotary motion into linear motion. Some of the most common are a winch, a rack and pinion and a screw mechanism. In this application, a screw mechanism is the most attractive because it is not easily back driven, it provides a high mechanical advantage, it is very low cost and it can be incorporated into a very simple design. One huge benefit of the screw is that it allows for a large mechanical advantage. If a motor has an operating torque of 1 mN-m at maximum efficiency is used in conjunction with a simple 6-32 screw and nut, it could generate 28 Newtons of force, which is ample for the actuator. Simple screw mechanisms are roughly 30% efficient. This means that the actuator requires more power, but that it requires very little power to hold the actuation force. Due to the reliability and simplicity, a simple screw mechanism is a very attractive solution for the actuator.

As mentioned above, feedback control is an important element of the actuator design. In order to incorporate feedback control, we must have a way of measuring the force at the output of the actuator. One convenient way to do so is to pull on one end of a spring, monitor the compression of the spring, and attach the wire to the other side of the spring. If the spring constant is known, the force exerted on the wire can be easily computed. Additionally, this allows for a bit of compliance in the system which could be useful if the rope stretches slightly. A spring constant on the order of 4400 N/m would result in a maximum spring compression of 3mm at the tar-

geted actuator force. A figure of the actuator design can be seen in Figure 6.16. While this design is simple, low

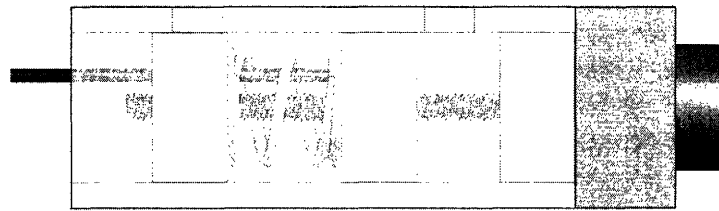

Figure 6.16

cost and reliable, it can not be released quickly. The actuator should be able to be released quickly to insure that the knee spring releases at the correct time. Since the spring/screw actuator does not allow for this, future work must be done in the design of an actuator that can be released quickly. The spring/screw actuator may be able to be used if the microprocessor signals the actuator slightly ahead of time.

The mechanical structure of the actuator is also important. It would be beneficial if the actuator's structure could be incorporated into the structure of the whole mechanism so that the number of needed parts could be minimized. In this case, the actuator is enclosed in a 26 mm box extrusion with 3.25 mm walls which results in a sturdy frame to which other structural components can be mounted. In this case, the box extrusion for the actuator can serve as a spacer to which a support for the drum axle can be mounted.

There are a variety of ways that the displacement between the two spring blocks can be monitored. The measuring device should preferably be low cost, relatively small and should be able to have measure the displacement to within 0.25 mm. There are a number of devices that can measure displacements to within 0.25 mm. Typically, price increases as the accuracy increases, but this is not always true.

Potentiometers are a very low cost method of measuring displacements, but in the past have tended to be unreliable because they use sliding contacts. New technologies, specifically conductive plastics, have greatly increased the reliability of potentiometers to the point that they could be used for this device. Either a linear potentiometer, or a rotary potentiometer with a rack and pinion or a drum and wire could be used to measure the displacement of the spring.

A variable parallel plate capacitor could be used to measure the displacement of the spring blocks, but suffers from two problems. It requires a relatively large surface area to be able to accurately measure the capacitance, and it requires the plates to be electrically isolated from one another. Although it is straightforward to electrically isolate the plates from each other, the low capacitance creates a more difficult problem to solve. This suggests that other alternatives should be explored.

Optically measuring the displacement of the spring is significantly better than both potentiometers and a variable capacitor. Typically, lines are etched into either glass or a plastic and a series of LED emitter/detectors count the number of lines that have passed through the beam. An accuracy better than 0.025 mm can easily be measured using this method. Although typically more expensive than the some other alternatives, the cost is reasonable for systems with 0.25 mm accuracy. Additionally, since there is no mechanical contact, there are no wear problems. Optical measuring devices can be compact and could be easily incorporated into the actuator. This combination of accuracy and reliability make this solution very attractive.

A Linear Variable Differential Transformer (LVDT) could also be used to measure the displacement of the spring, but they tend to be extremely expensive and are a poor choice for this application. A group of LED emitter/detectors with an etched plastic slide is a very reliable, compact, accurate, and low cost way to measure distance. A conductive plastic potentiometer also has these qualities but has a lower lifetime. There appears to be at least two solutions to this problem, and therefore testing of each solution will have to be conducted to see which is better.

Based upon the 17 Newton force, the 6 mm stroke, the 30% efficiency of the screw and the 70% efficiency of the motor, it requires roughly 0.2 joules to freeze the drum. Since there are two actuators acting per step, each step requires roughly 0.4 joules. If a 3.6V, 2.1Ah lithium battery that can store roughly 27000 joules is used in each knee brace, and the stride length is 1.63 meters, the user will be able to walk for 80 km per battery when the power consumption of the electronics are included. Battery life could be greatly increased by additional wraps around the drum, or by using a larger battery.

6.5 Control System

Advances in accelerometer technology allows extremely small, accurate two axis accelerometers that can be manufactured for a very low price. This allows accelerometers to be mounted to different parts of the brace so that the relative angles to gravity can be measured. Additionally, they can detect the change in acceleration at heel strike. This allows a substantial amount of relevant information to be gathered.

Pressure sensors could be mounted in the shoe to detect heel strike and gather information about the WTE. Either a capacitive sensor or a force sensing resistor could be used to do this. These sensors should be able to provide enough input that a suitable control algorithm could be developed. This paper will not discuss the details of such a system. These components (aside from sensors in foot) are small enough so that they could be easily integrated into mechanical apparatus.

6.6 Structural Design

One representation of the knee brace architecture is shown in Figure 6.17. The struts running along each side are made from steel 2.36 mm thick by 32 mm wide. This size was chosen because it is readily available. Because of time pressures, no finite element analysis was done on this component, although it could be easily be made wider or thicker if needed.

From the solid model, the reader can see that the actuators are at an angle relative to the thigh and shank. This design was chosen over a design where the actuators are parallel to the thigh and shank for a number of reasons. The angled configuration does not require an idler pulley, which decreases the number of components and also the distance from the axis of the knee to the end of the actuator.

Although the parallel configuration may provide more structural strength than the angled configuration, the increase in strength does not justify the additional complexity of having an idler pulley. On the other hand, it is easier to obtain a large mechanical advantage with the parallel configuration because the actuator can pull at an angle, giving a $1/\sin(\theta)$ multiplicative effect. Ultimately the angled configuration was chosen because it allows for a more simple structure, it still provides substantial structural support, and calculations show that the additional mechanical advantage is not needed.

Another important consideration is that of bearings and joints. R4 bearings are sufficiently strong enough, but are difficult to attach to a 2.36 mm thick plate without complications. For this reason, bearings will be used in places that allow for them, and simple bushings will be used in tighter spaces. The drum support is also another important consideration. It is advantageous to minimizing the overall thickness of the device, but it must be strong enough, and the strength of the drum support decreases dramatically as the thickness decreases. No finite element analysis was completed, but this component could be made wider if needed. For this reason time was spent on other more important components.

The padding and straps for the thigh and calf are extremely important. It should be noted that the image above is not an accurate portrayal of the straps. The actual straps will be very similar to the straps and padding in modern knee braces.

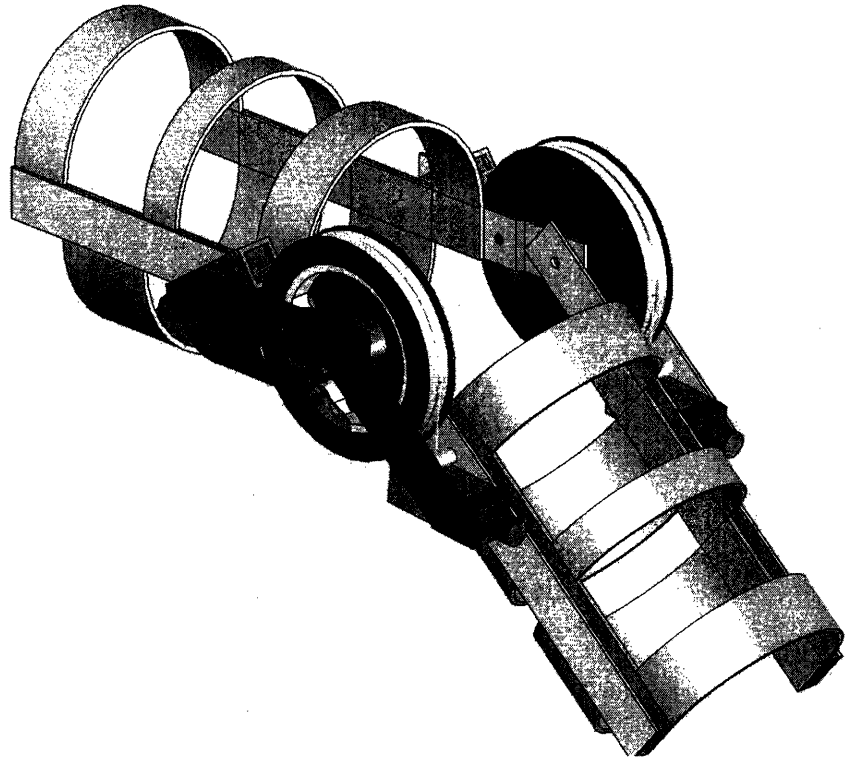

Figure 6.17

7 Conclusion

This thesis postulates the idea that incorporating a dynamically configurable torsion spring at the knee offers the promise of reducing the metabolic energy consumption of walking. After examining prior art it is clear that other inventors have been interesting in solving this problem. It is also clear that they had a basic understanding of the various problems to be solved but were unable to create a practical solution to the problem. It is conjectured that there are two primary reasons for lack of past success. The first is they had an incomplete understanding of the theory behind the interaction between kinetic, potential and knee spring energy. Secondly and probably the primary cause of failure is that the technology available to them was simply not available. The advent of high speed computers and simulation tools has greatly helped with the first problem while the advent of composite materials, low power microprocessors and MEMS sensors has mitigated the technology issue.

This thesis has attempted to improve our understanding of the interaction between the kinetic, potential and knee spring energy in the walking cycle. This allowed us to describe of the functionality requirements, the architecture, and the mechanisms which are needed to create quasi lossless walking/running. Use of the capstan effect appears to offer a solution to these functionality requirements.

A simplified model was created having a torso point mass supported via legs composed of a massless thigh and shank bodies. A dynamically configurable torsion spring coupled the thigh and shank leg elements. Simulations showed that the amount of torso kinetic energy transferred to the knee spring was dependent on the horizontal torso velocity and the heel strike angle. This showed that a system having a higher torso velocity but a smaller heelstrike seg angle can transfer exactly the same amount of energy into the knee spring as a system having a lower torso velocity but a lower heelstrike angle. It was shown that the angle of the stance leg seg when the spring energy is released must equal the negative of the angle of the stance leg seg when the spring is at maximum torsion. If this condition is not satisfied, the average horizontal force does not equal zero and the average vertical force does not equal to the torso weight. These appear to be necessary and sufficient conditions for lossless walking/running assuming the simplified model is valid. It was shown that these conditions can be achieved if the spring constant is chosen such that the maximum torsion of the spring occurs when the torso is directly over the ankle. These conditions can also be achieved if the knee is frozen at maximum spring angle and released after the torso has rotated over the ankle. The later scheme was chosen to explore further because it appears to be easier to implement.

Several knee spring latching mechanisms were examined including ratchets, disc brakes, drum brakes, and capstan effect wire rope brakes. Assuming the shank is directly coupled to one leg of the torsion spring, there appear to be four requirements of the latching mechanisms:

- a microprocessor controlled mechanism to couple the thigh to one end of the torsion spring;
- a mechanical mechanism to freeze the knee angle when the energy stored in the spring is maximum;
- a microprocessor controlled mechanism to release the energy stored in the spring;
- a microprocessor controlled mechanism to dissipate energy created during period of positive work.

The capstan effect wire rope scheme was chosen because it has all of the right attributes. A design was introduced which embodies the architectural ideas and several of the key components were designed. A curved cantilever composite spring made from Kevlar was constructed and tested. The mechanical advantage of the capstan effect was measured using stainless steel wire rope wrapped around drums with different surface coatings. A jig was created to prove that the capstan braking method was an effective way to freeze the drum.

Potential solutions for the interface between the human body were discussed. Particular focus was placed on solving the problem of tissue compression. Several designs for the actuator were discussed and the power consumption of the system was estimated.

The simulations show that it is in theory possible to create a system that significantly reduces the energy consumption of walking. After the system requirements and the architecture was decided, plausible solutions were found for several critical problems. Future work must be involve finding a solution to the control algorithm

and improvements to the actuator design. Once a solution to the control algorithm is found, it is felt that a system that implements these concepts and mechanisms discussed can significantly reduce the energy consumption of human walking.

8 Bibliography

1. Frank C. Anderson, Marcus G. Pandy, "Dynamic Optimization of Human Walking," October 2001, Vol 123, Journal of Biomechanical Engineering.
2. Best, Ben, "Lessons for Cryonics from Metallurgy and Ceramics," 14 April 2004 <<http://www.ben-best.com/cryonics/lessons.html>>.
3. B. Laursen, D. Ekner, E.B. Simonsen, M. Voigt, G. Sjogaard, "Kinetics and energetics during uphill and downhill carrying of different weights," Applied Ergonomics 31 (2000) 159-166.
4. Choon-Young Lee, Ju-Jang Lee, "Estimation of Walking Behavior Using Accelerometers in Gait Rehabilitation."
5. Andre Heck, Andre Holleman, "Mathematics and Physics of Walking."
6. Emmanuel Cordier, Ambarish Goswami, Mathiew Bourlier, "Kinematic Parameterization of Natural Slope Walking."
7. Steven H. Collins, Martin Wisse, Andy Ruina, "A Three-Dimensional Passive-Dynamic Walking Robot with Two Legs and Knees," The International Journal of Robotics Research, Vol 20, No 7, July 2001, pp. 607-615.
8. Kenton R. Kaufman, S. E. Irby, J. W. Mathewson, R. W. Wirta, D. H. Sutherland, "Energy-Efficient Knee-Ankle-Foot Orthosis: A Case Study," Journal of Prosthetics and Orthotics, Vol 8, Number 3, Summer 1996.
9. Mariano Garcia, Anindya Chatterjee, Andy Ruina, "Speed, Efficiency, and Stability of Small-Slope 2-D Dynamic Bipedal Walking."
10. Filipe M. Silva, J. A. Tenreiro Machado, "Energy Analysis During Biped Walking," Proceedings of the 1999 IEEE International Conference on Robotics & Automation, Detroit, Michigan, May 1999.
11. J. Maxwell Donelan, Roder Kram and Arthur Kuo, "Simultaneous positive and negative external mechanical work in human walking," Submitted to J. Biomechanics, Sept. 2000, Accepted, Mar 2001.
12. Steven E. Irby, Kenton R. Kaufman, James W. Mathewson, and David H. Sutherland, "Automatic Control Design for a Dynamic Knee-Brace System," IEEE Transactions on Rehabilitation Engineering, Vol. 7, No. 2, June 1999.
13. Arthur D. Kuo, "Stabilization of Lateral Motion in Passive Dynamic Walking," The International Journal of Robotics Research, Vol. 18, Mo. 9, September 1999, pp. 917-930.
14. T. Suga, O. Kamey Ama, R. Ogawa, M. Matsuura, H. Oka, "Newly designed computer controlled knee-ankle-foot orthosis," Prosthetics and Orthotics International, 1998, 22, 2230-239.
15. J. Maxwell Donelan, Rodger Kram, and Arthur D. Kuo, "Mechanical and Metabolic Cost as a Function of Step Width in Human Walking."
16. Arthur D. Kuo, "A Simple Model of Bipedal Walking Predicts the Preferred Speed-Step Length Relationship," Transactions of the ASME, Vol. 123, June 2001 pp. 264-269.
17. J. Maxwell Donelan, Rodger Kram and Arthur D. Kuo, "Mechanical work for step-to-step transitions is a major determinant of the metabolic cost of human walking," The Journal of Experimental Biology 205, 3717-3727 (2002).
18. Arthur D. Kuo, "Energetics of Actively Powered Locomotion Using the Simplest Walking Model," Journal of Biomechanical Engineering, Feb. 2002, Vol. 124, pp. 113-120.
19. "Device on Horizon Could Help Orthosis Wearers Bend Knees When They Walk," inSCOPE newsletter.

20. Arthur D. Kuo, "The relative roles of feedforward and feedback in the control of rhythmic movements," submitted to Motor Control, May 2000.
21. Ossur 2003 Calalog (manufacturer of Flexfoot).
22. Brian G. Rennex, "Energy-Efficient Running Brace," US Pat. No. 4,967,734.
23. G. John Dick, Eric A. Edwards, "Human Bipedal locomotion device," US Pat. No. 5,016,869.
24. Jean-Louis Chaireire, "Mechanical Leg-Propulsion Assistance Device," US Pat. No. 4,872,665.
25. Jr. MacCready, Paul B., "Walking Assisting Apparatus," US Pat. No. 6,666,796.
26. G. Pierce, "Jumping Shoes," US Pat. No. 3,388,485.
27. John L. Brennan, "Pneumatic springing shoe," US Pat. No. 4,133,086.
28. Eli Razon, "Device for assisting running, walking or jumping," US Pat. No. 5,362,288.
29. Stewart Kenneth McKay, Christopher Kirtley, "Walking aid," US Pat. No. 5,658,242.
30. Robert J. Brannigan, "Leg Support Device," US Pat. No. 6,409,693.
31. J. Stephens, "Drum Brake Handout." 20 April 2004 <<http://pottersville.tripod.com/drumbrk1.jpg>>.
32. E-composites, "Engineering Material Properties." 12 April 2004 <http://www.e-composites.com/common-Files/engineering_material_properties.asp>.
33. Jessica Rose, James G. Gamble, "Human Walking." Lippincott, August 2000.
34. Ferris DP, Liang K, Farley CT, "Runners adjust leg stiffness for their first step on a new running surface." Journal of Biomechanics 32: 787-794, 1999.
35. DJ Ortho 2003 Catalog.
36. R. Grasso, L. Bianchi, F. Lacquaniti, "Motor Patterns for Human Gait: Backward Versus Forward Locomotion," The American Physiological Society, pp. 1868-1881, 1998.
37. Peter Weyand, Deborah Sternlight, Matthew Bellizzi, Seth Weight, L. Bianchi, "Faster top running speeds are achieved with greater ground forces not more rapid leg movements," The American Physiological Society, pp. 1991, 1999, 2000.
38. Unknown author, "Linear Kinetics (GRF) Lab," Lab Notes.
39. Unknown author, "Biomechanics of running and body composition," October 26 and 27 Furman University.