



(19) **United States**

(12) **Patent Application Publication**
Chu

(10) **Pub. No.: US 2005/0258210 A1**

(43) **Pub. Date: Nov. 24, 2005**

(54) **PASSIVE EXOSKELETON**

(52) **U.S. Cl. 224/637**

(76) **Inventor: Conrad Chu, Piscataway, NJ (US)**

(57) **ABSTRACT**

Correspondence Address:
TOPE-MCKAY & ASSOCIATES
23852 PACIFIC COAST HIGHWAY #311
MALIBU, CA 90265 (US)

A load bearing apparatus is presented in the form of a passive exoskeleton whereby a load may be placed on the passive exoskeleton and thereby weight of the load from the passive exoskeleton is transferred to a ground surface. The passive exoskeleton is made of a rigid body member for attaching proximate a portion of a user's body; a sliding rod attached with the body member; a ground surface engageable foot analog attached with the sliding rod; a rocker pivotally attached with the body member; a load pin attached with the sliding rod and operably attached with the rocker; and a bias block attached with the body member for engaging with the rocker. As a user walks, the bias block pivots the rocker to aid the load pin in transferring weight to the rocker and thereafter through the sliding rod to the foot analog and ground surface.

(21) **Appl. No.: 11/031,425**

(22) **Filed: Jan. 6, 2005**

Related U.S. Application Data

(63) Continuation-in-part of application No. 10/850,202, filed on May 19, 2004.

Publication Classification

(51) **Int. Cl.⁷ A45F 3/04**

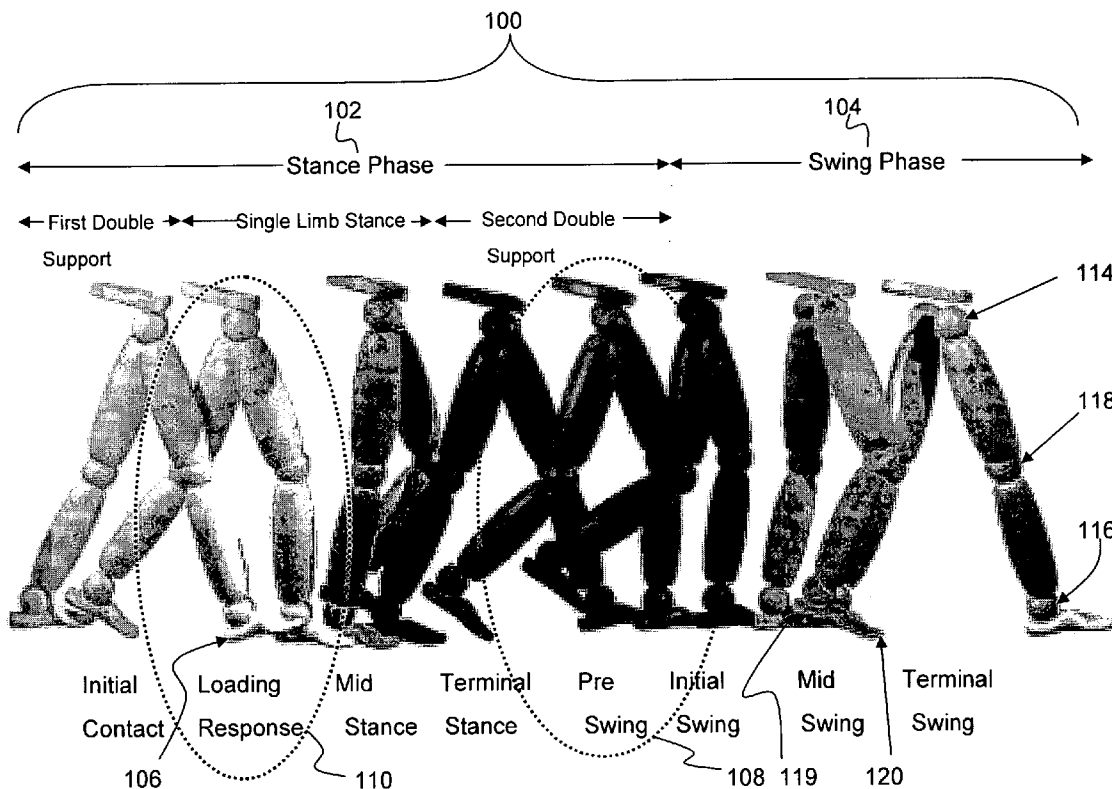

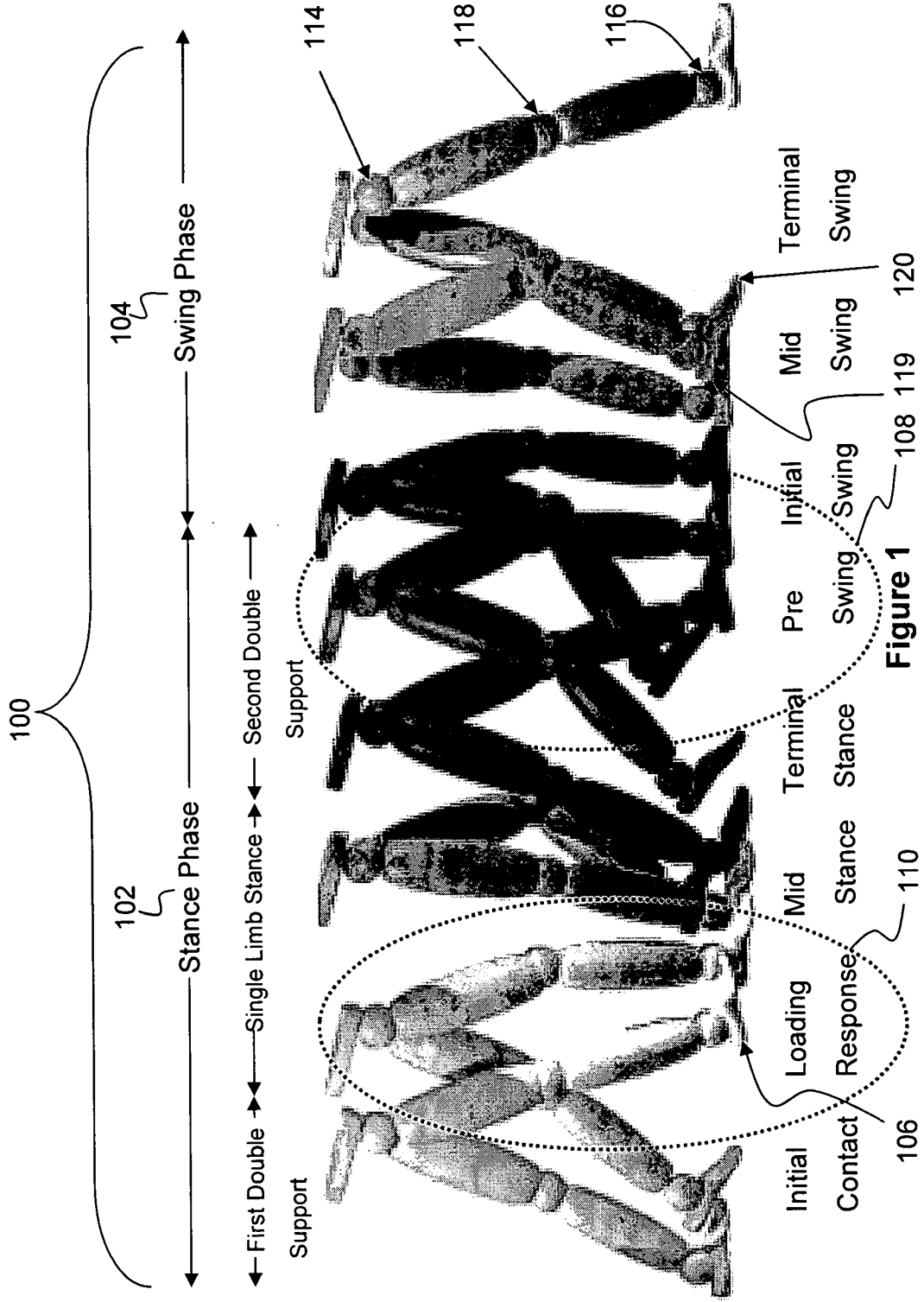
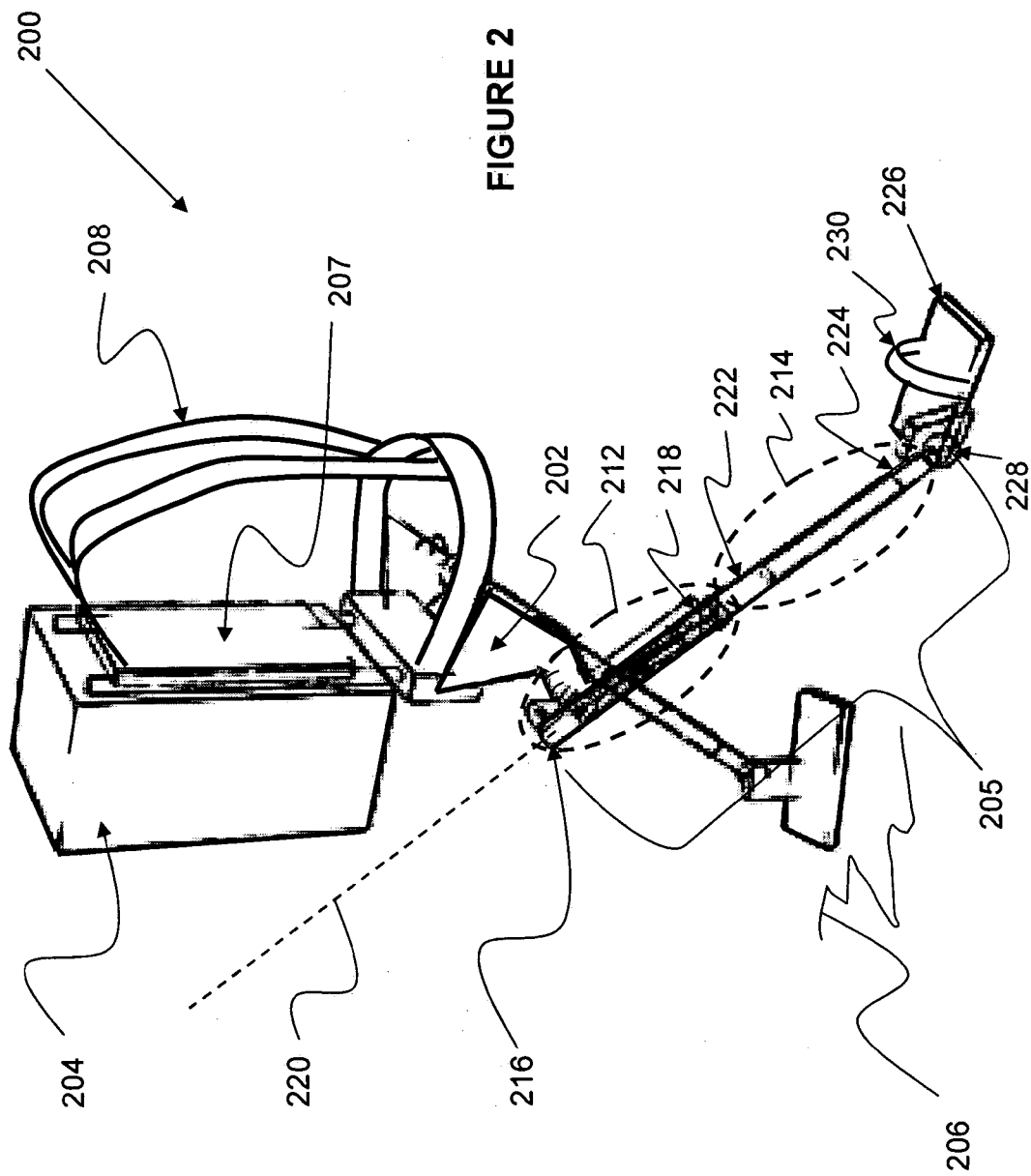
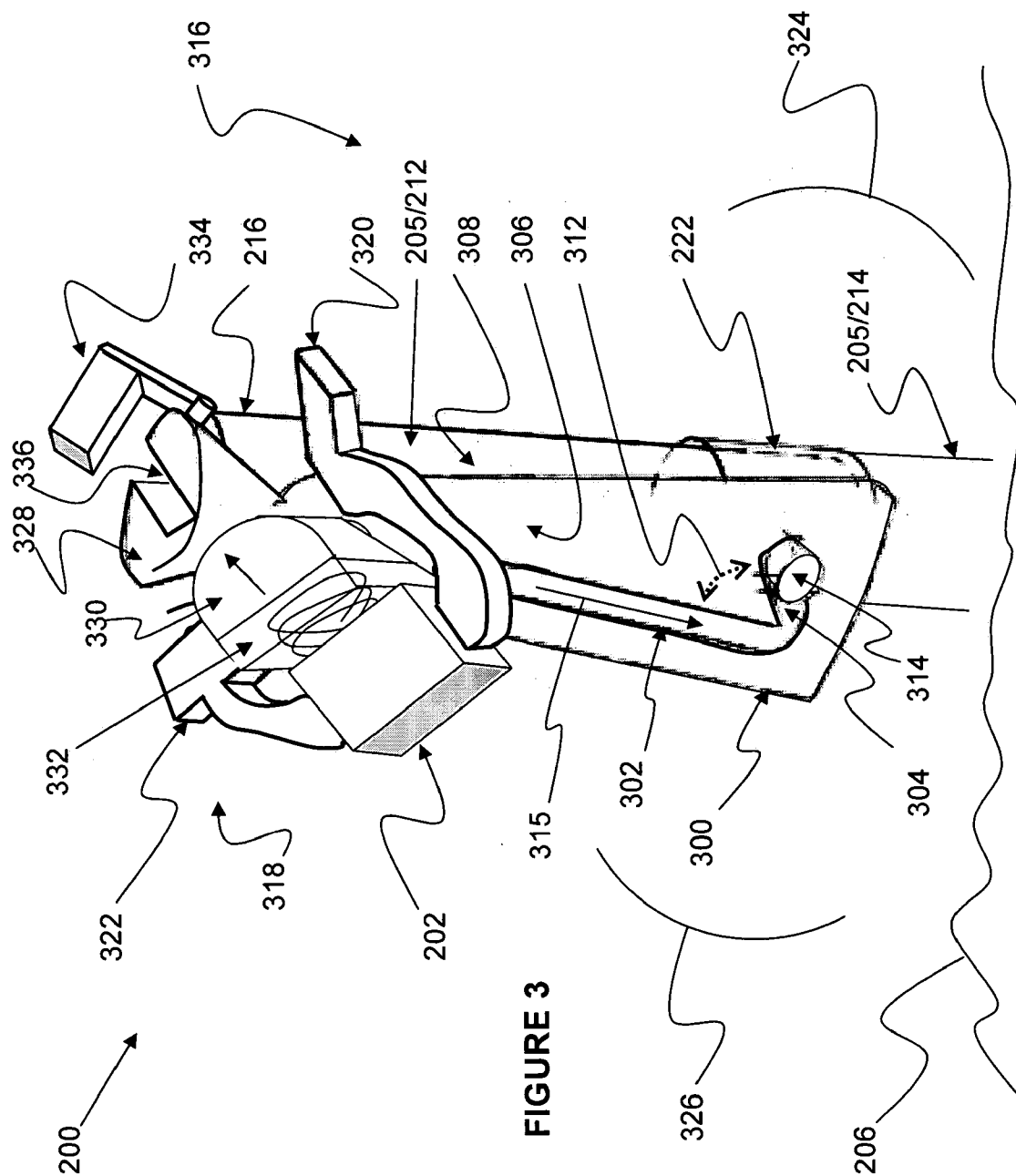

Figure 1





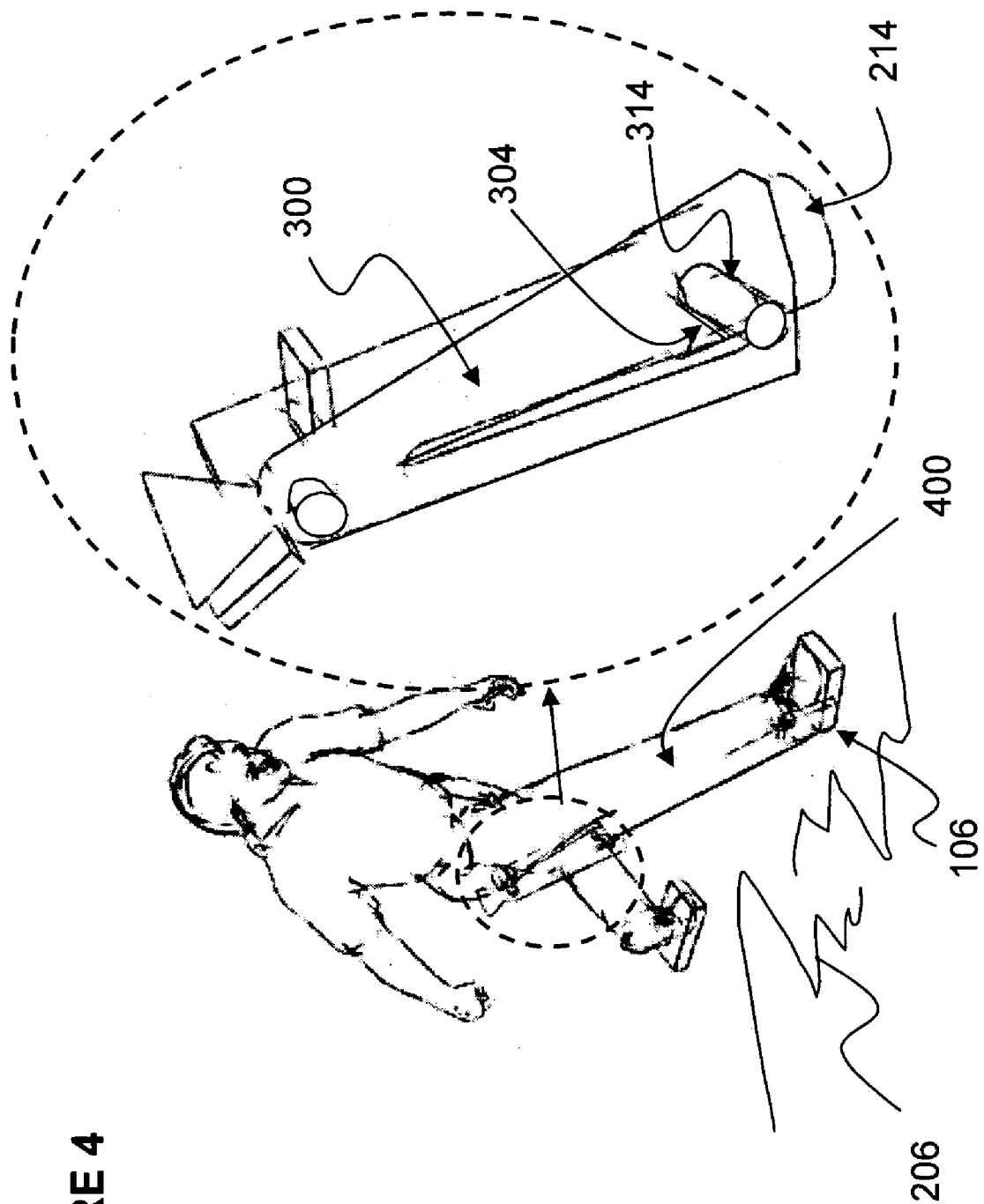

FIGURE 4

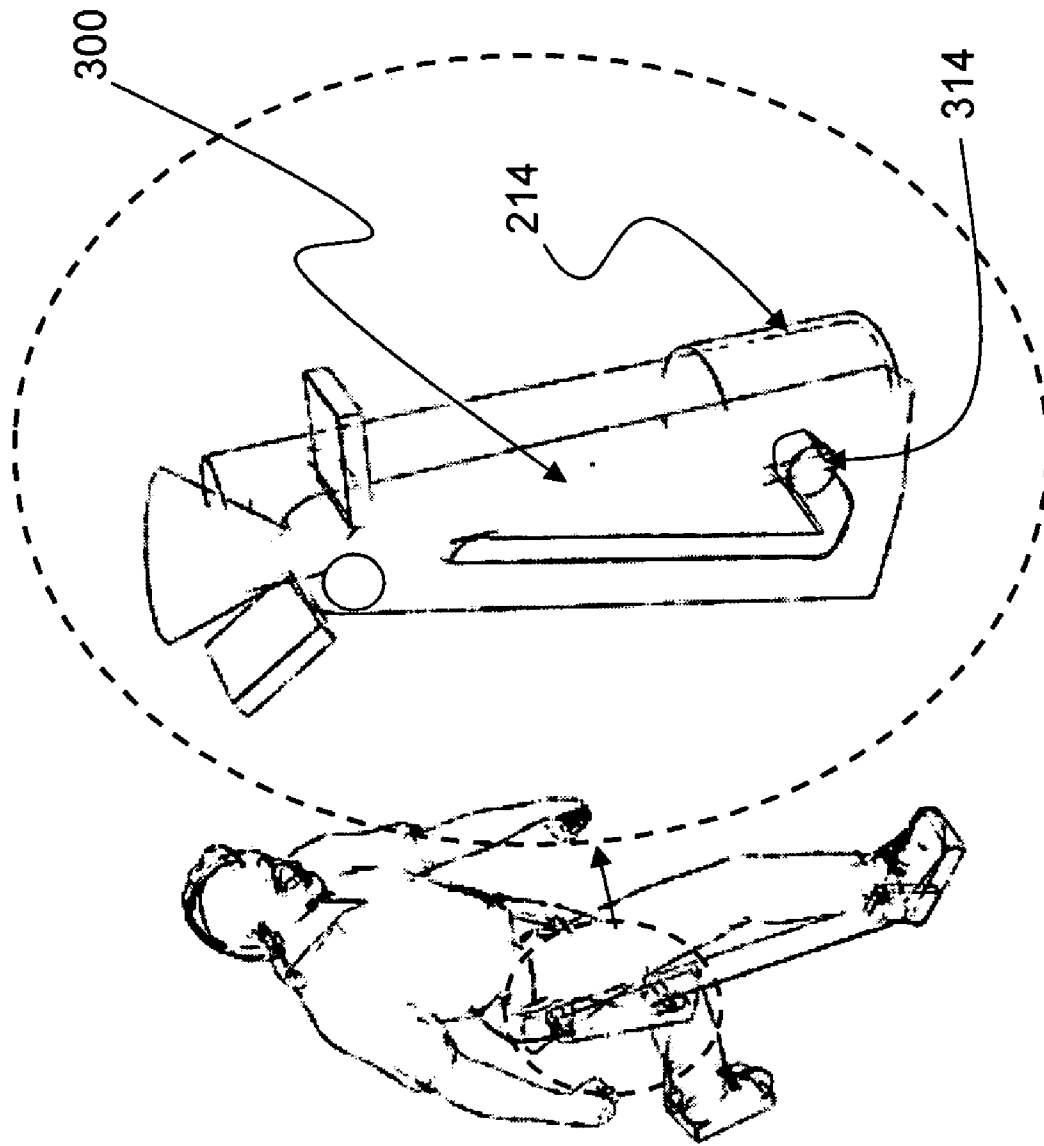

FIGURE 5

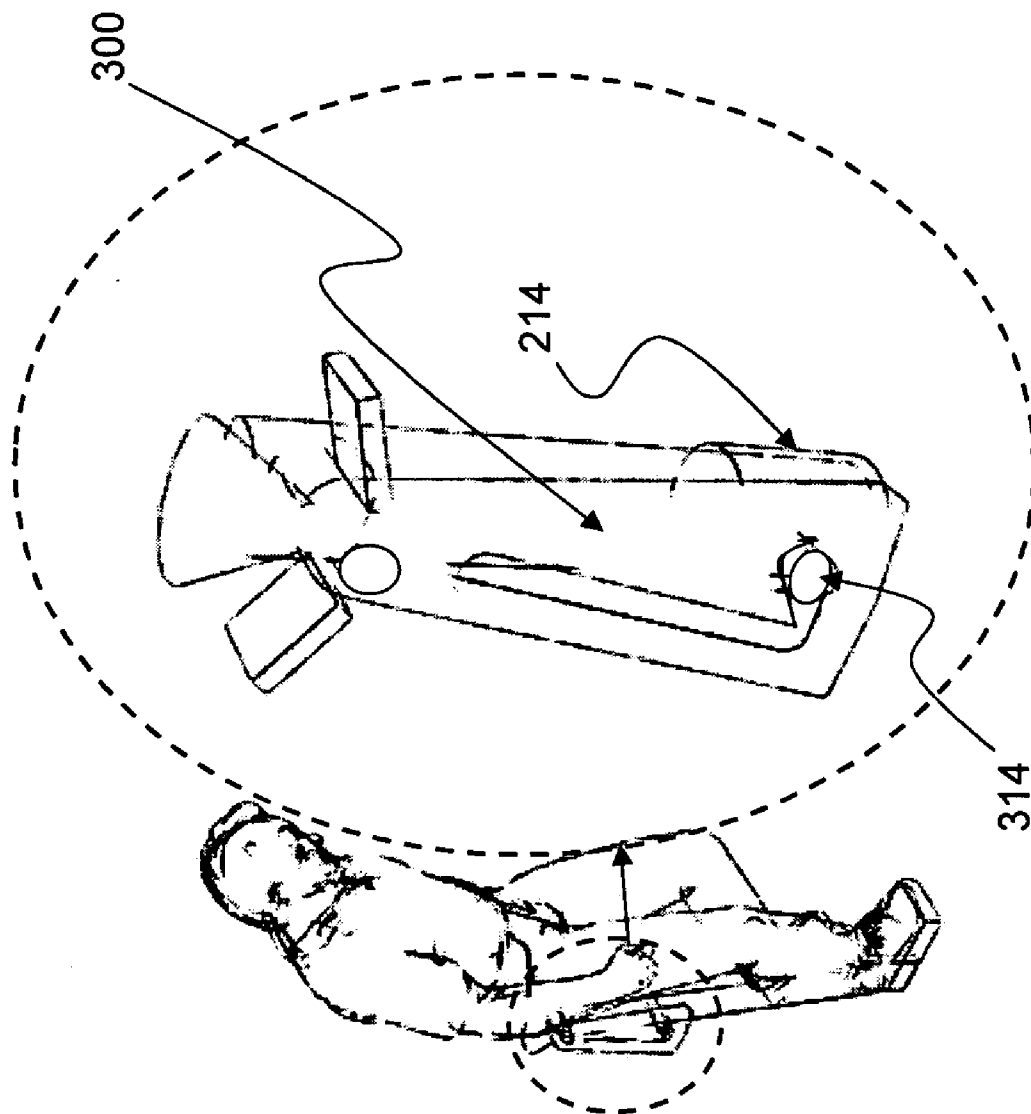

FIGURE 6

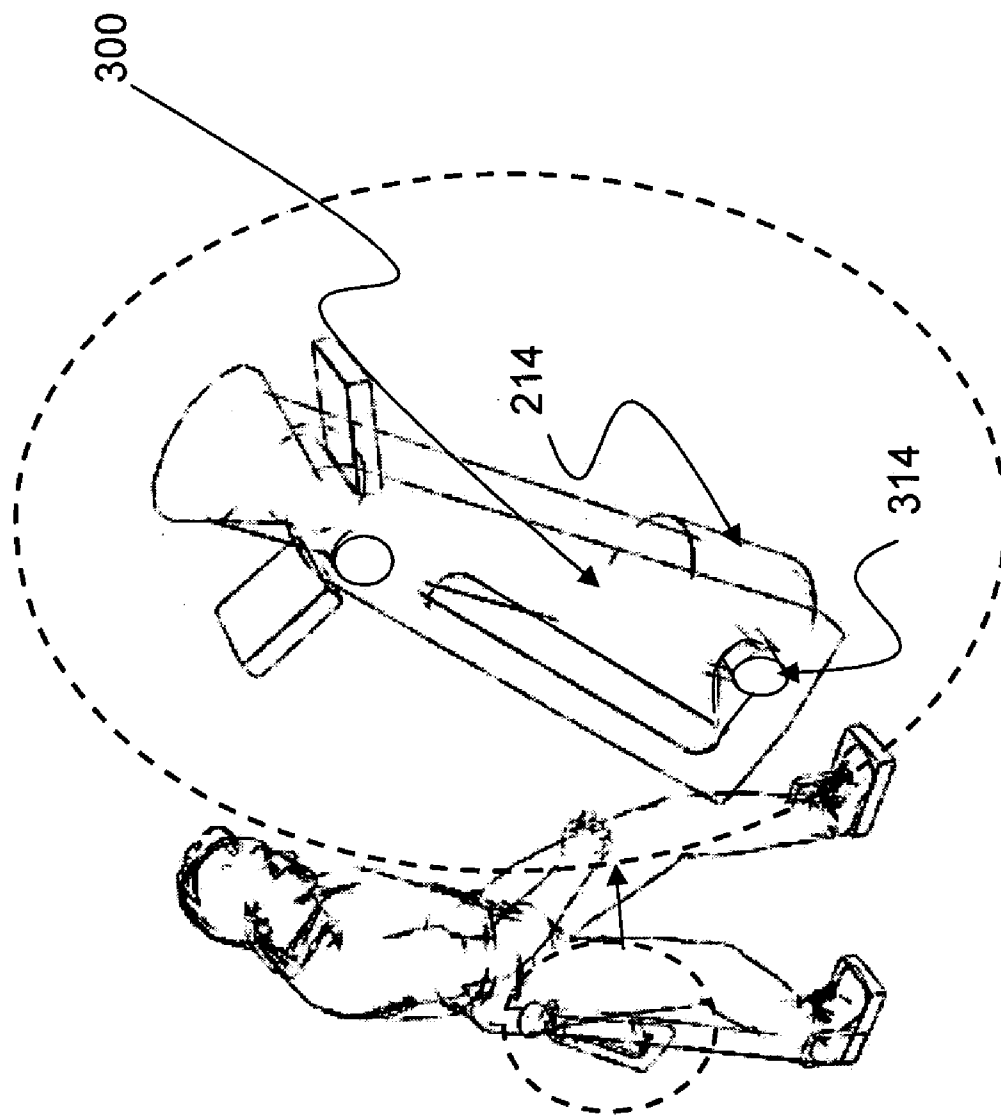

FIGURE 7

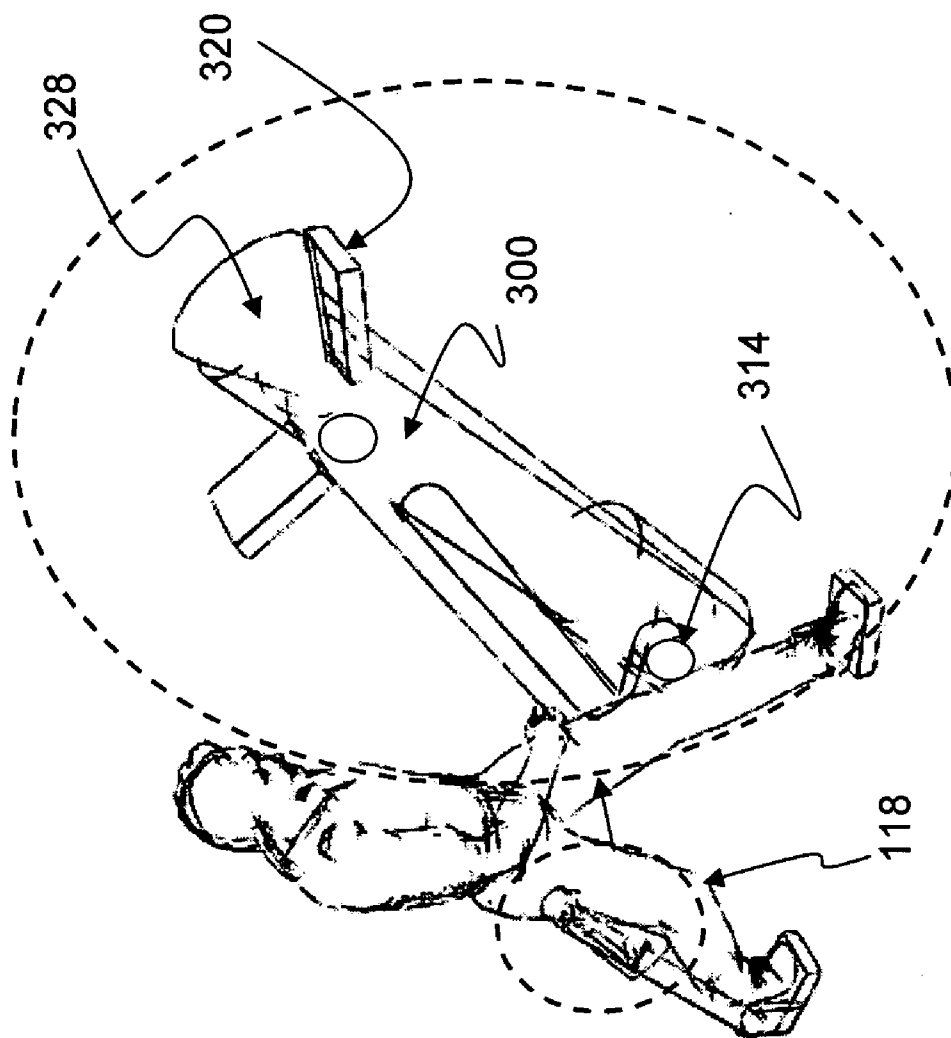

FIGURE 8

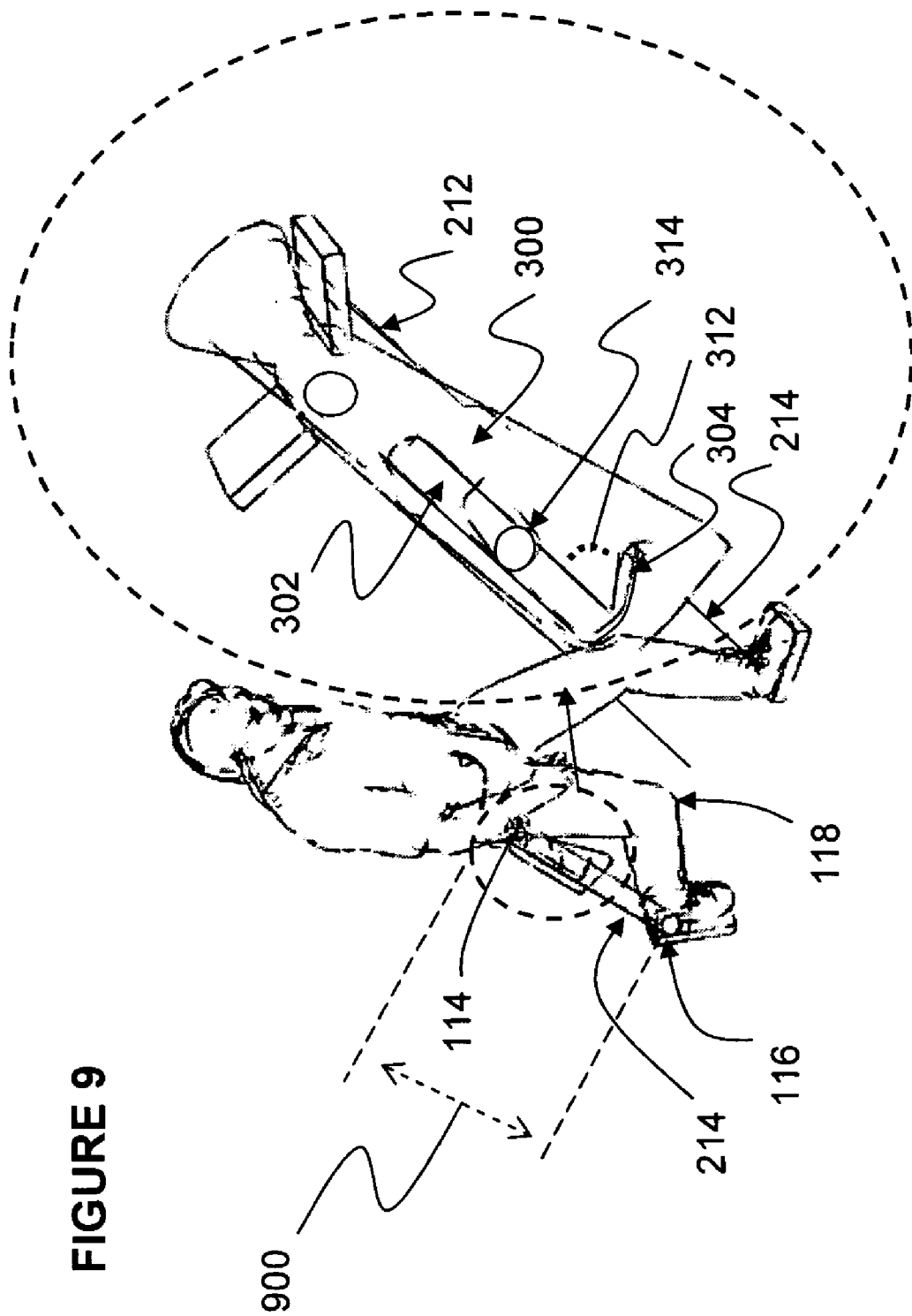

FIGURE 9

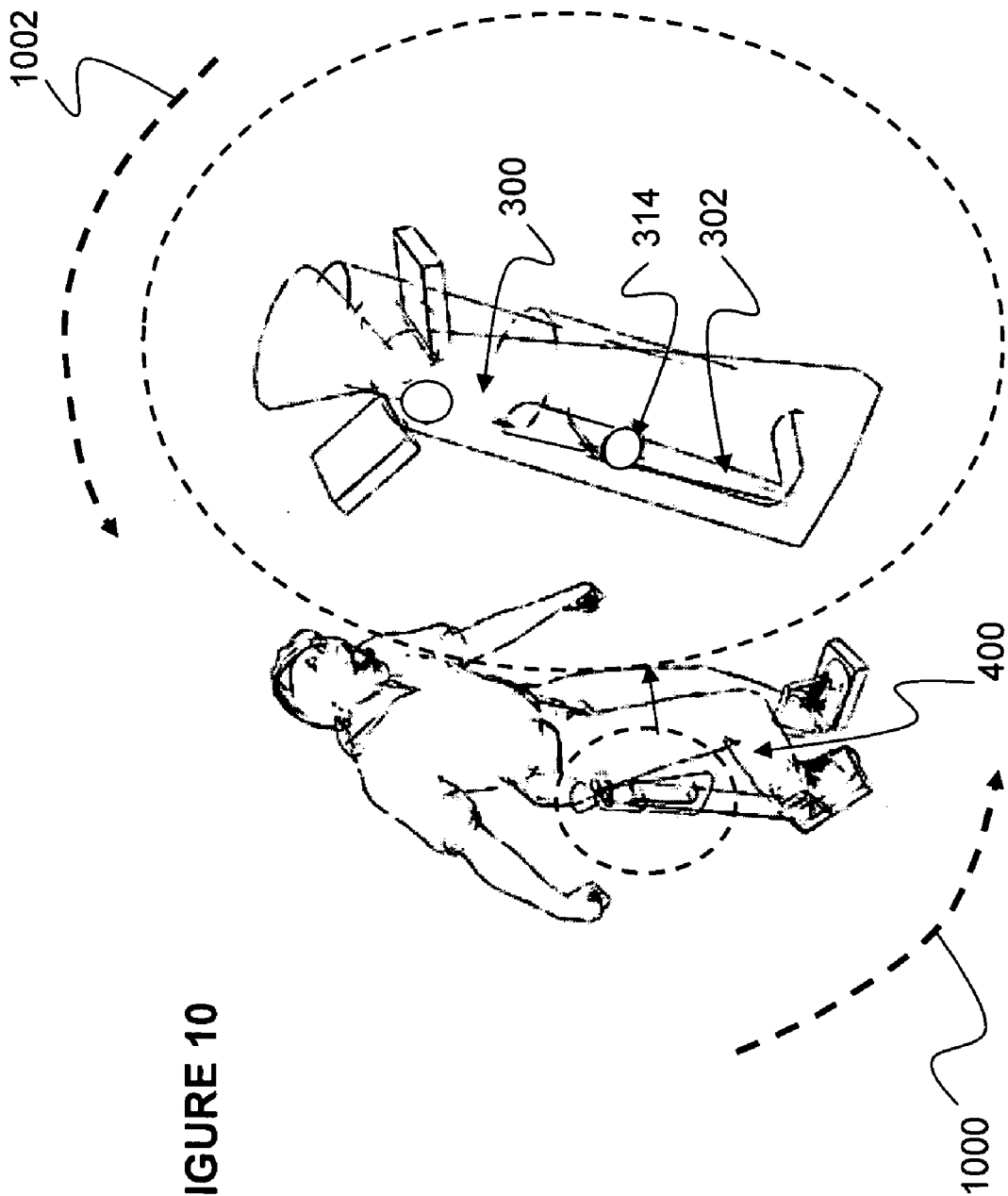

FIGURE 10

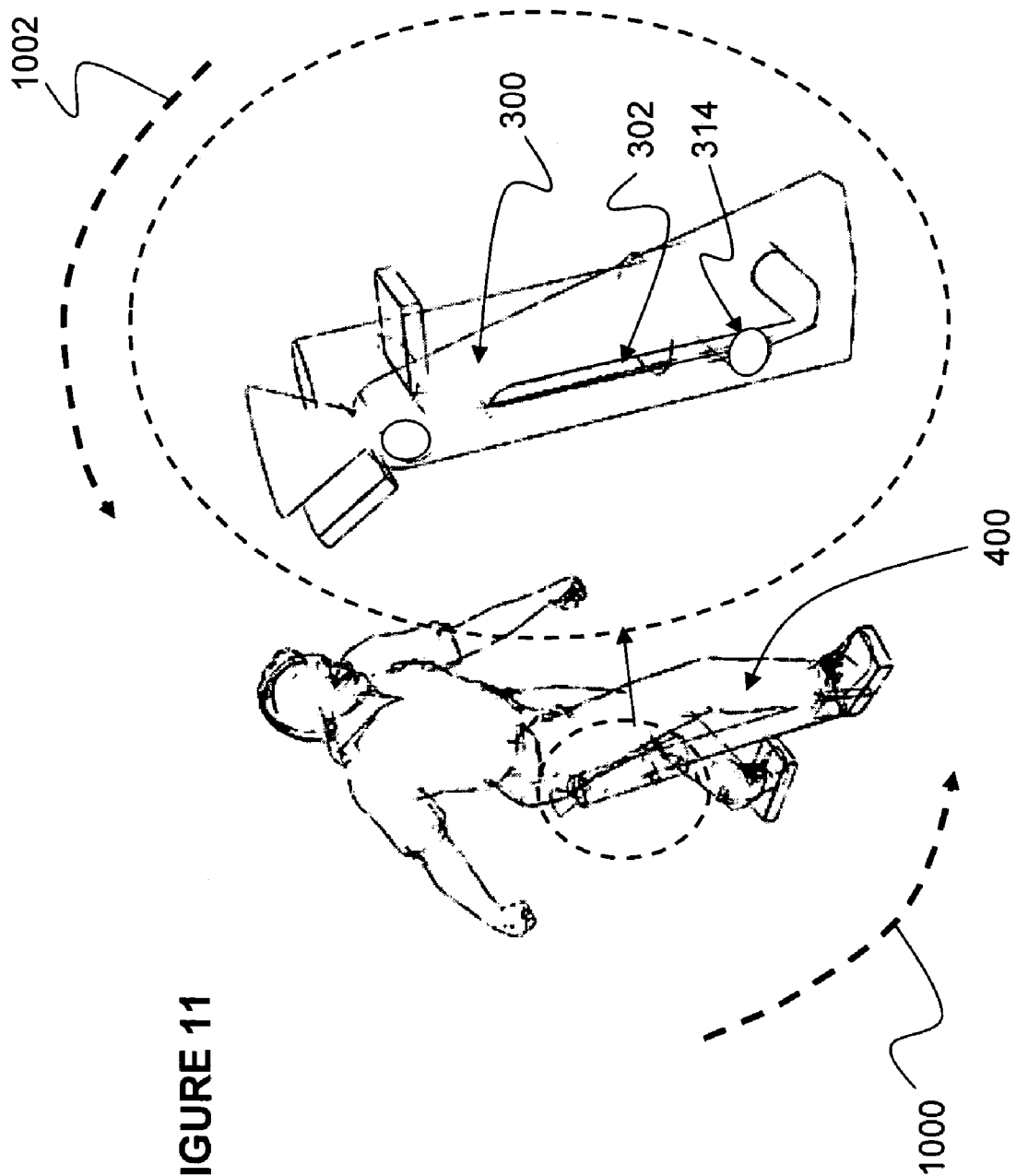

FIGURE 11

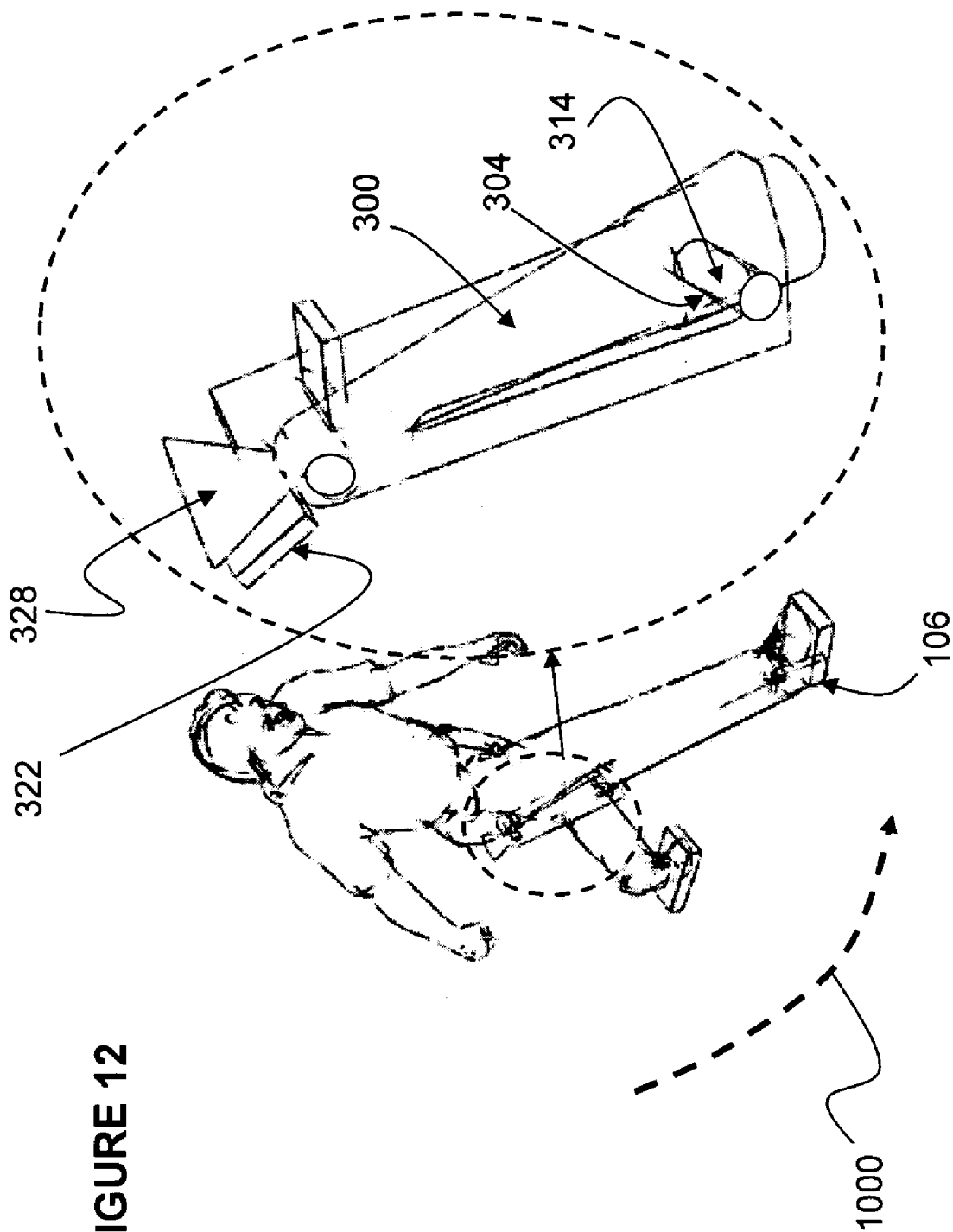

FIGURE 12

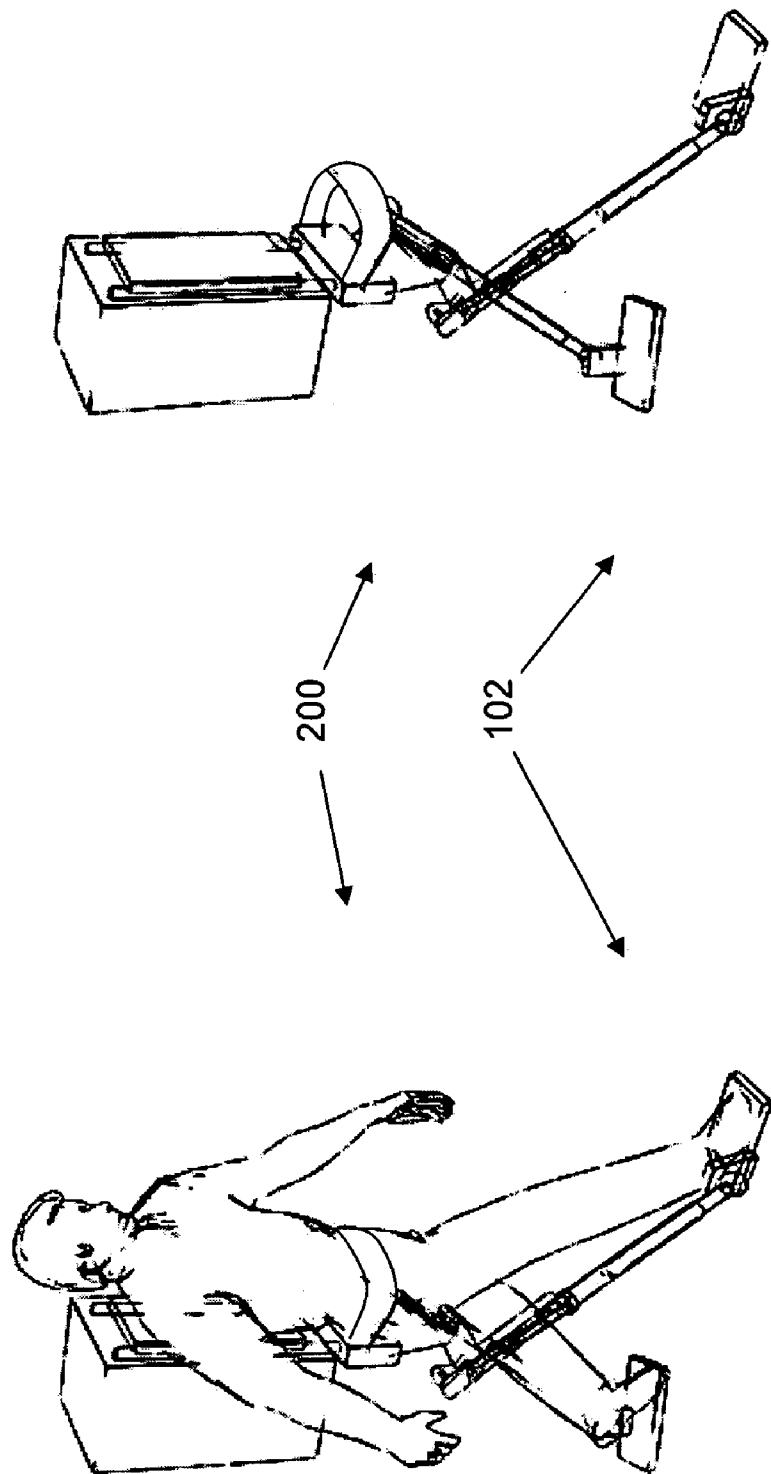

FIGURE 13B

FIGURE 13A

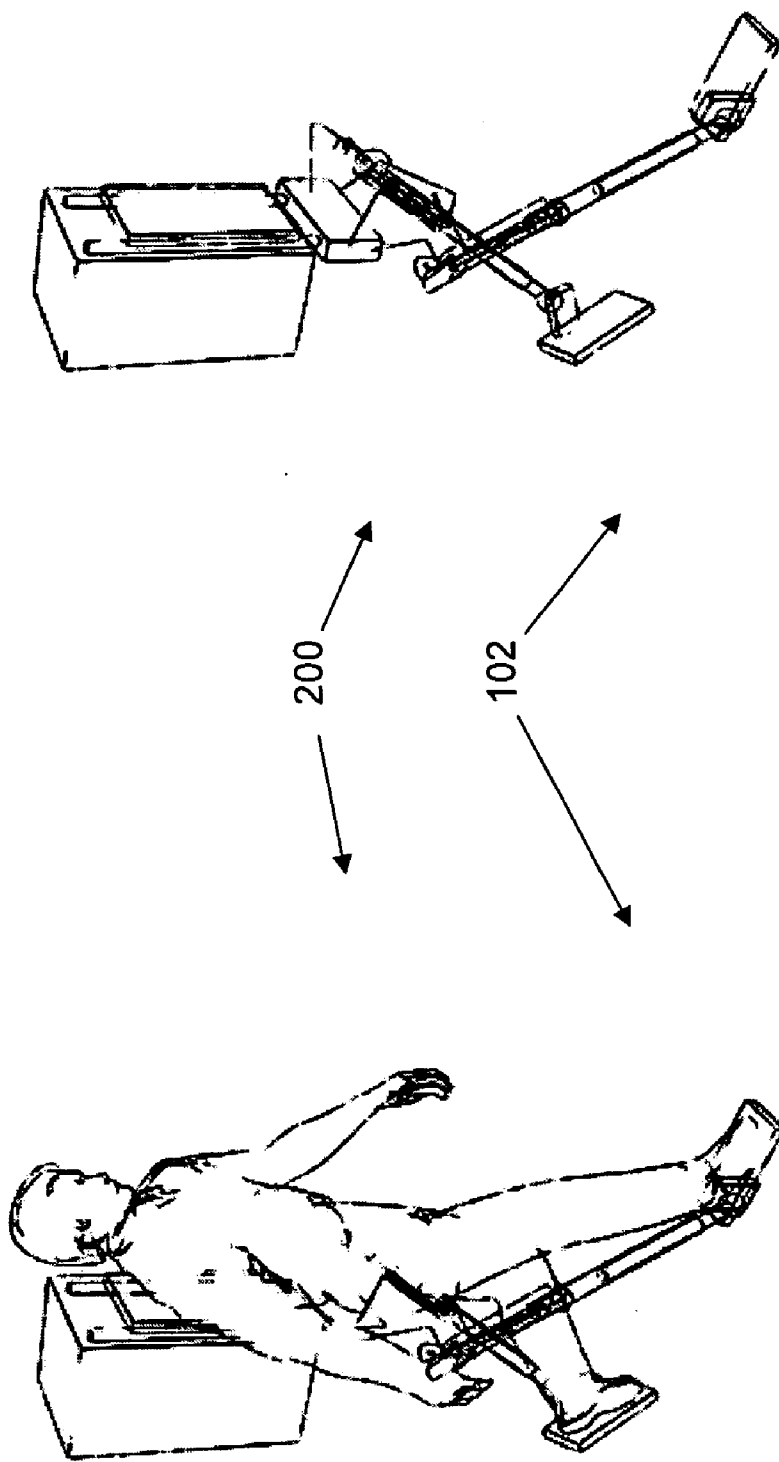

FIGURE 14B

FIGURE 14A

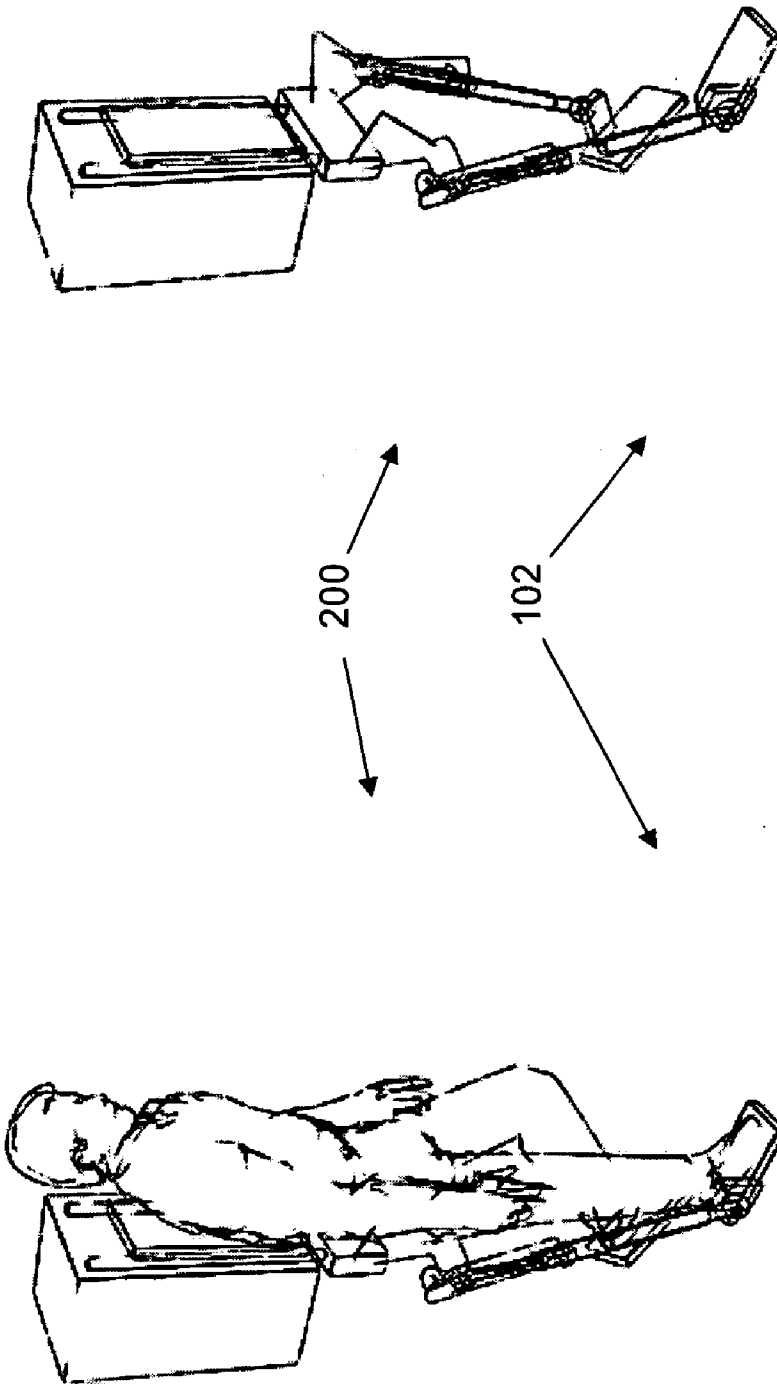

FIGURE 15B

FIGURE 15A

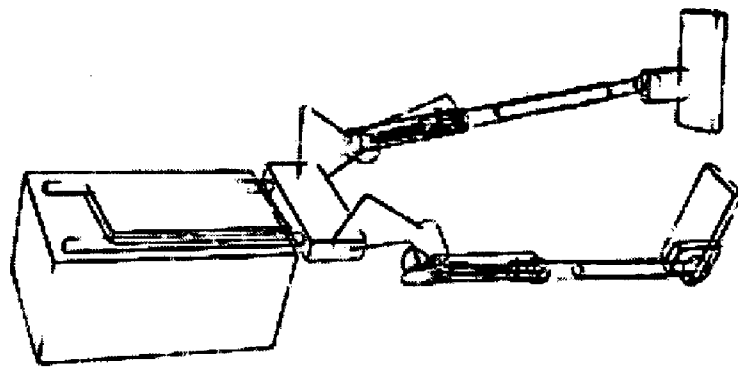

FIGURE 16B

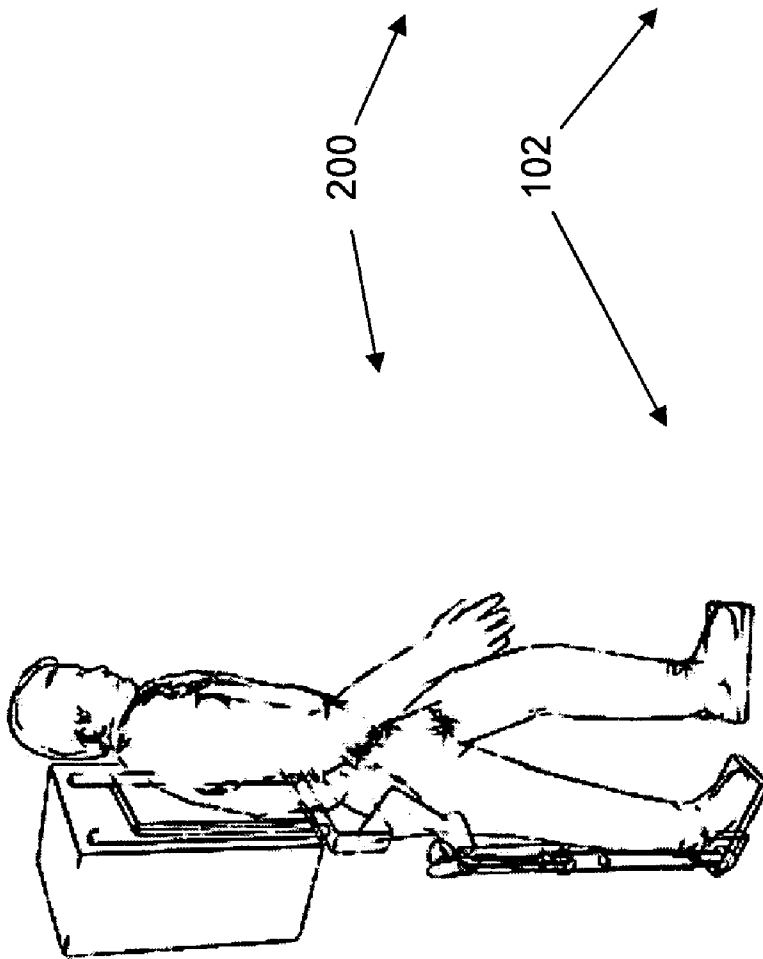

FIGURE 16A

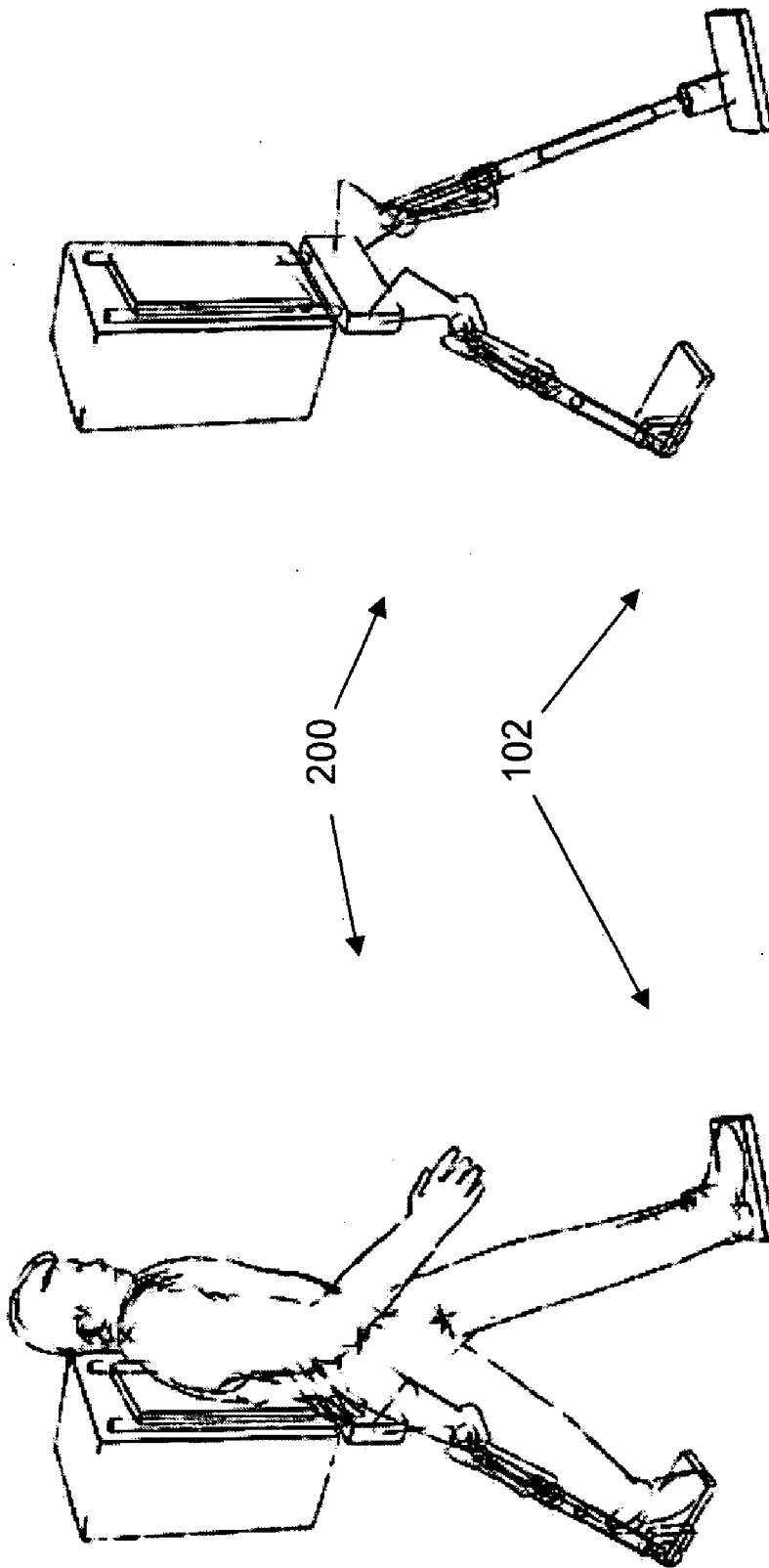

FIGURE 17B

FIGURE 17A

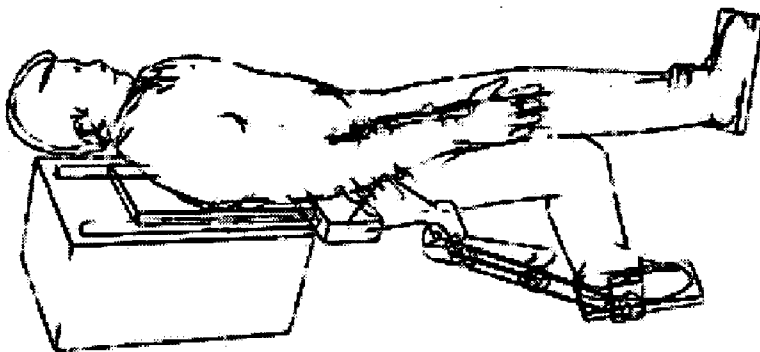
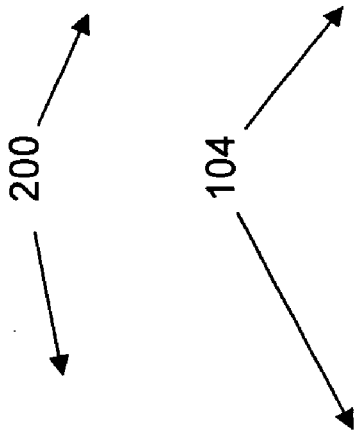
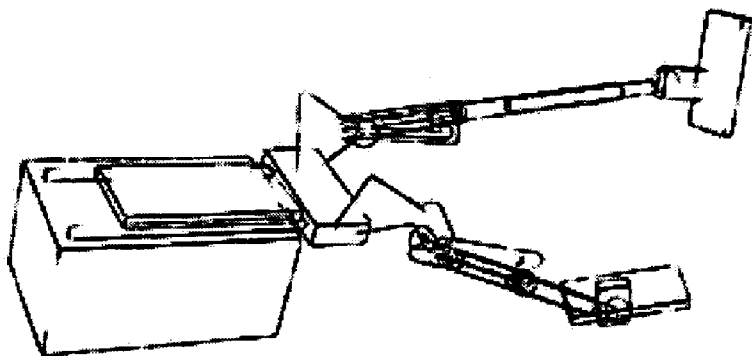

FIGURE 18B

FIGURE 18A

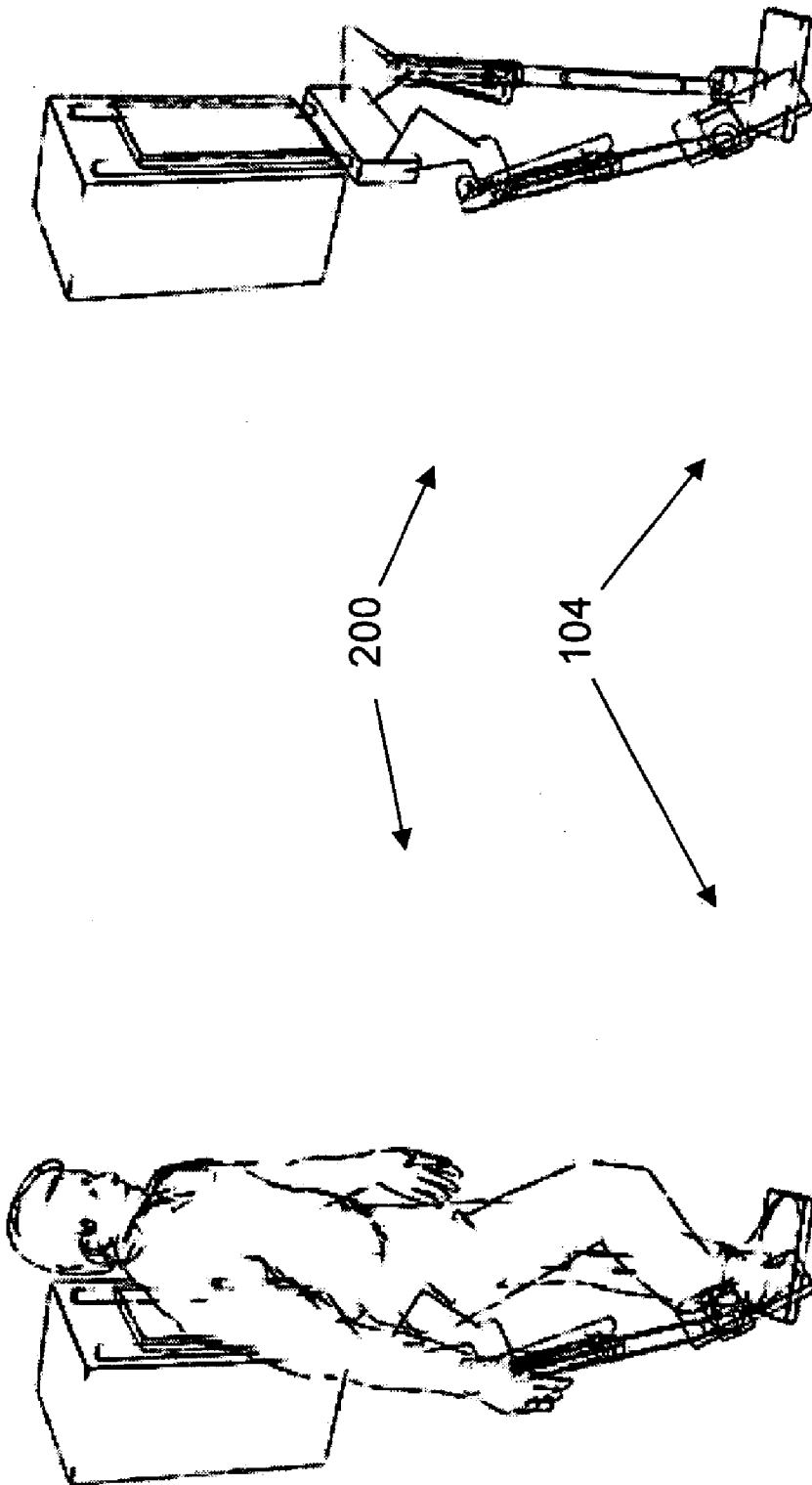

FIGURE 19B

FIGURE 19A

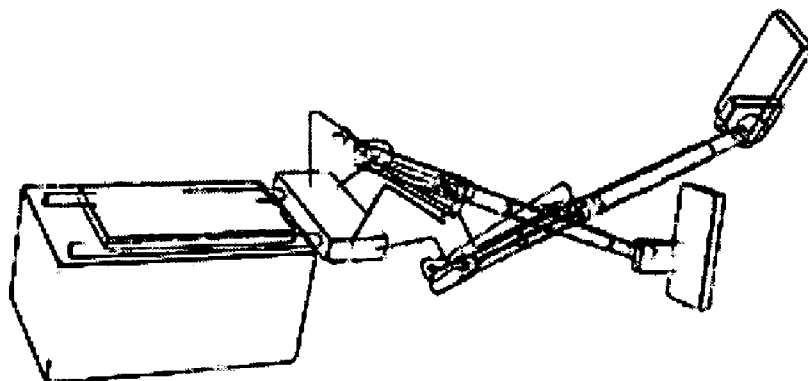

FIGURE 20B

200

104

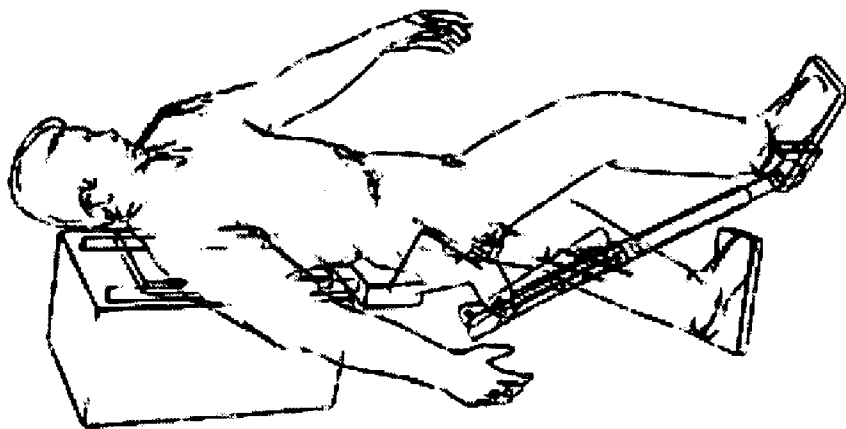

FIGURE 20A

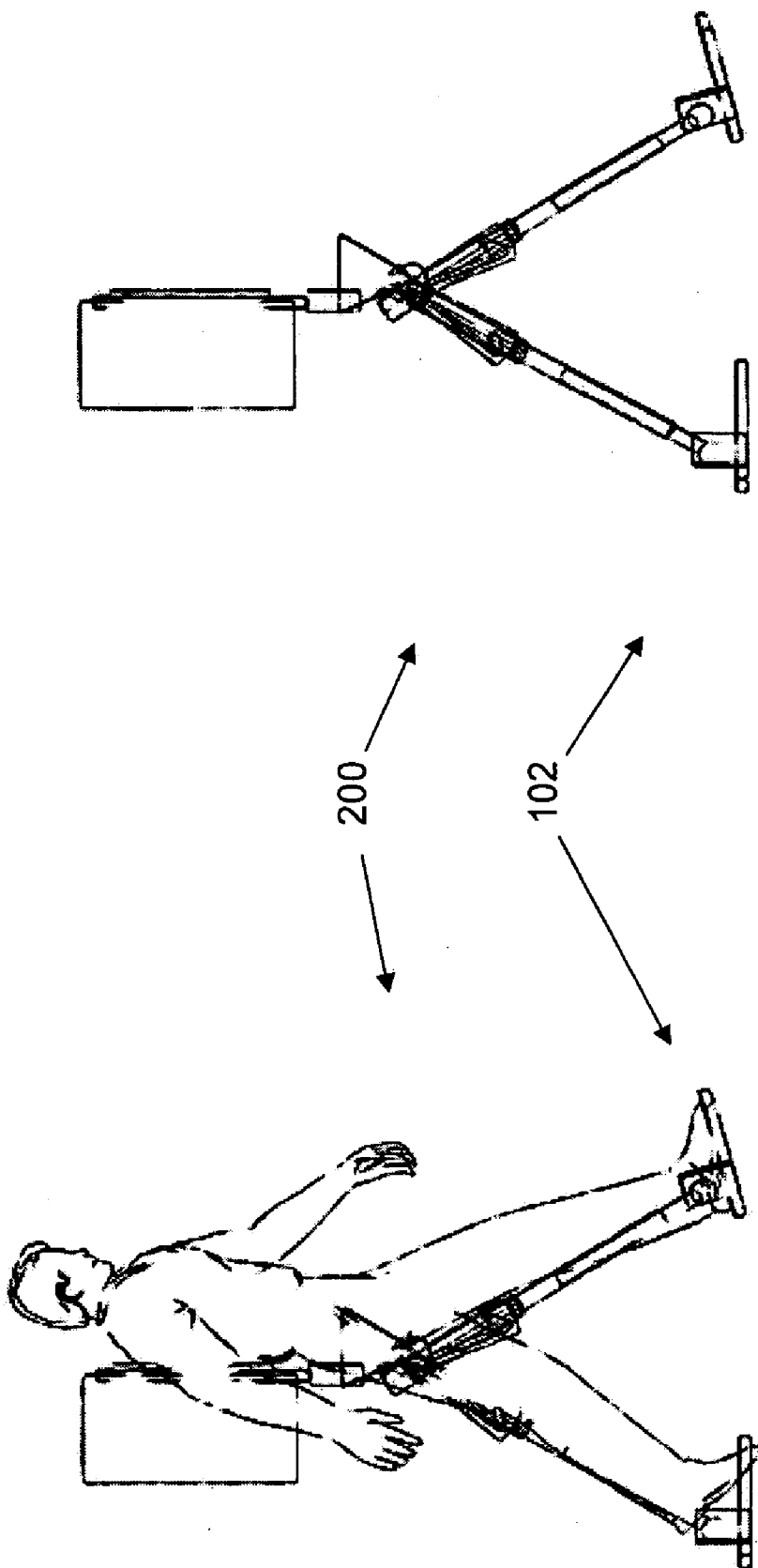

FIGURE 21B

FIGURE 21A

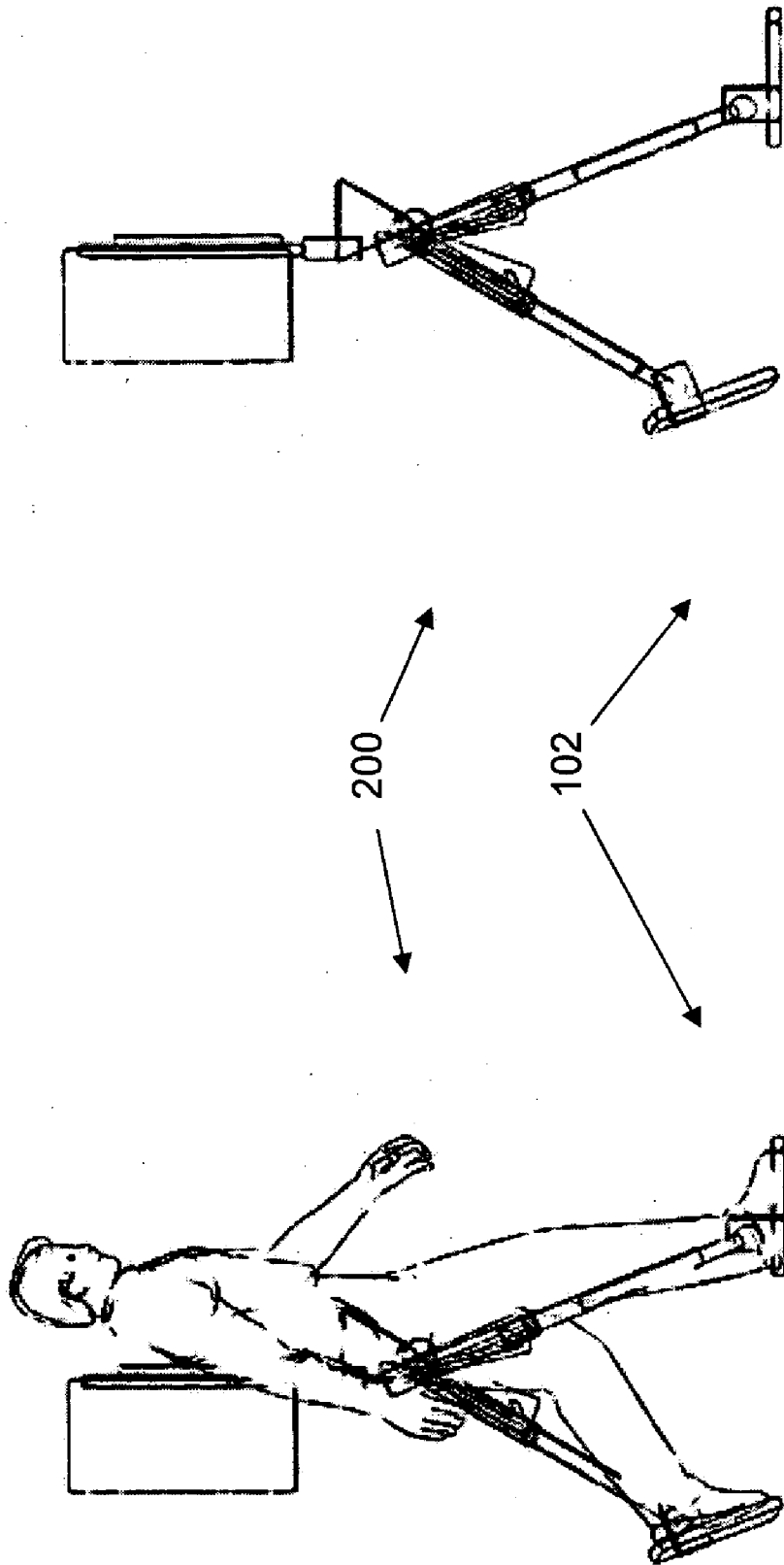

FIGURE 22B

FIGURE 22A

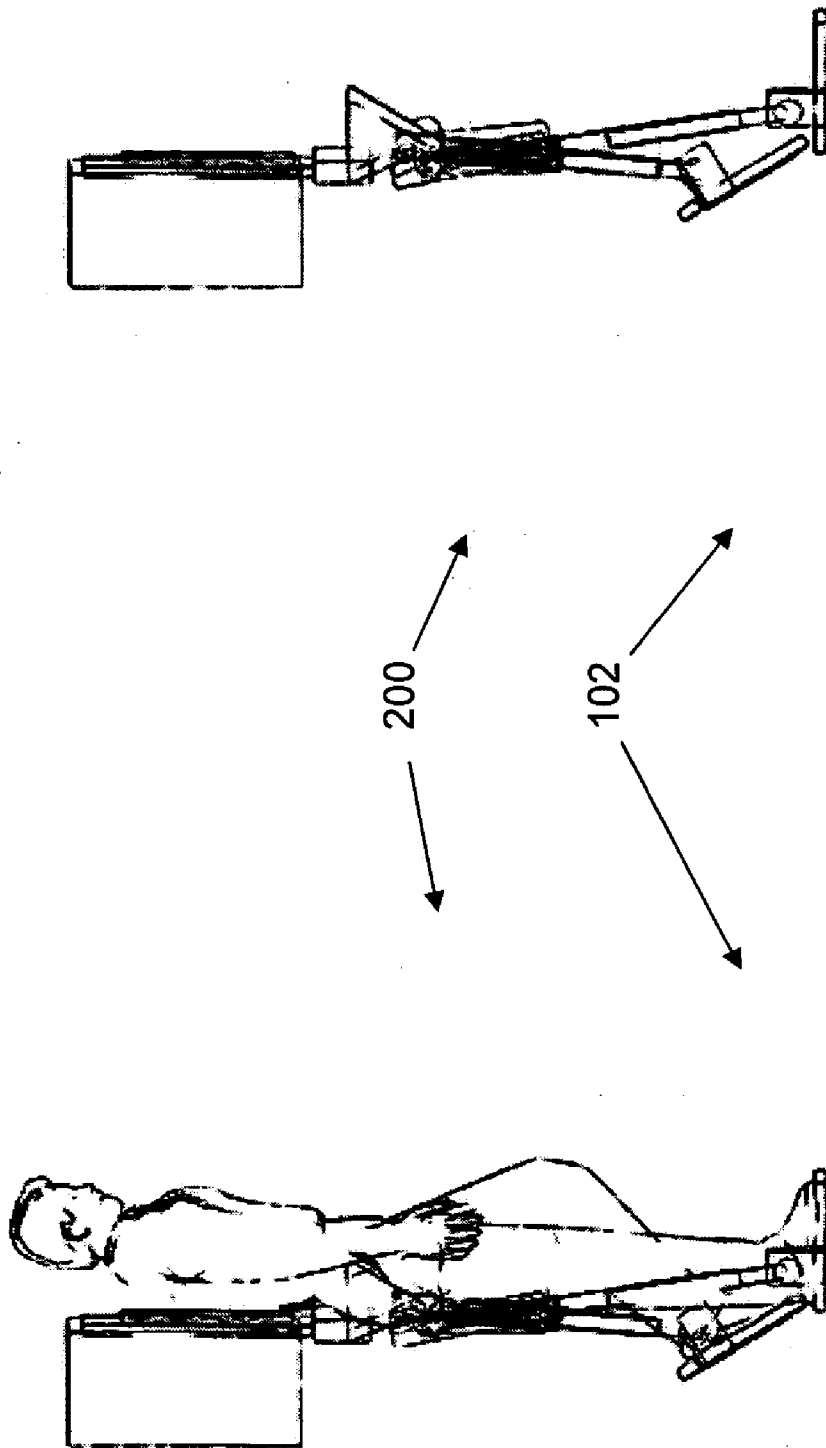

FIGURE 23B

FIGURE 23A

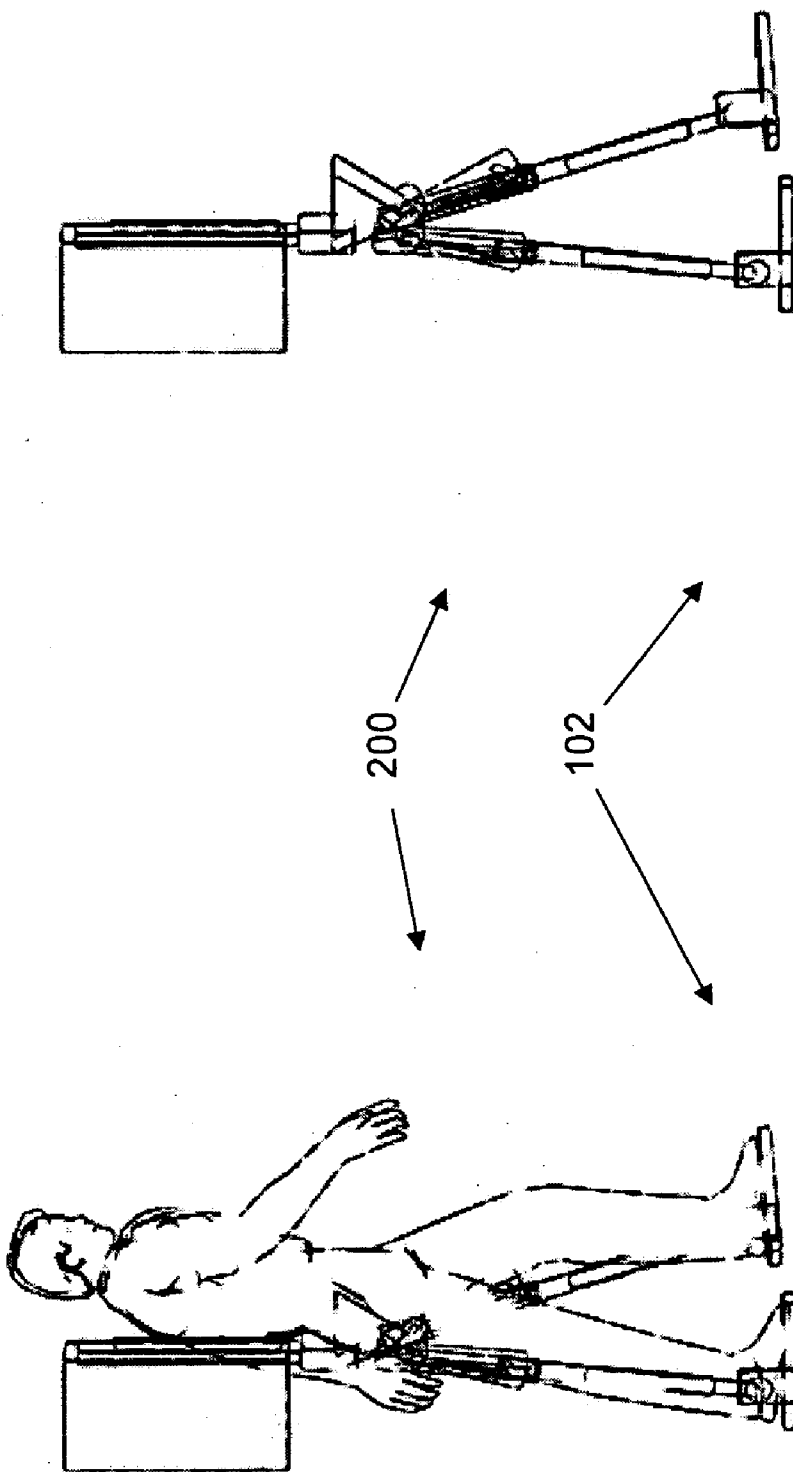

FIGURE 24B

FIGURE 24A

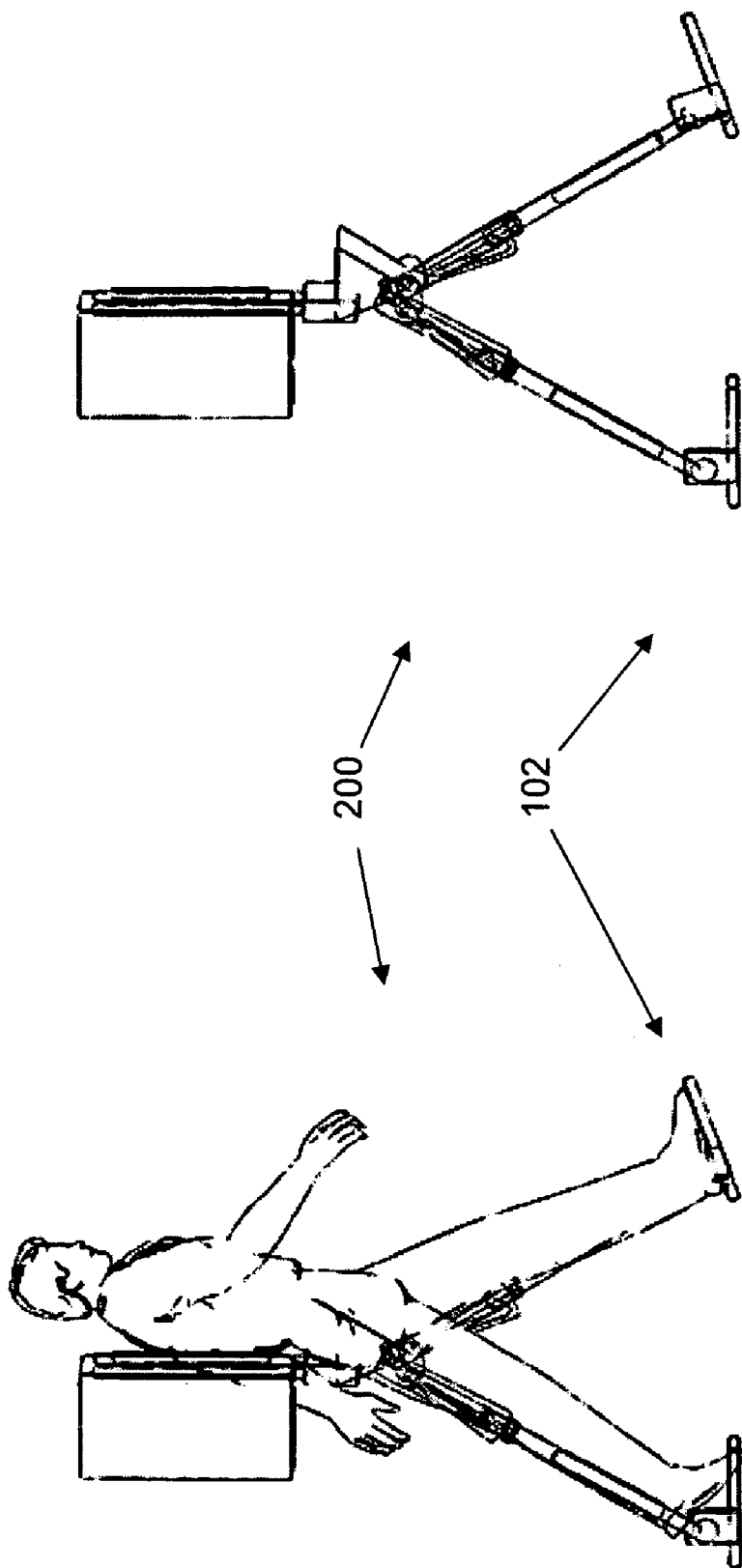

FIGURE 25B

FIGURE 25A

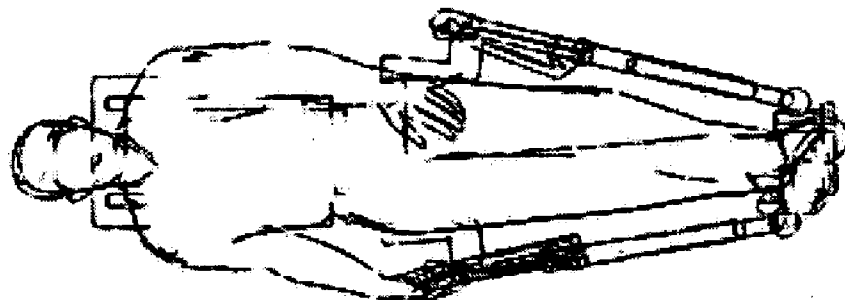

FIGURE 26A

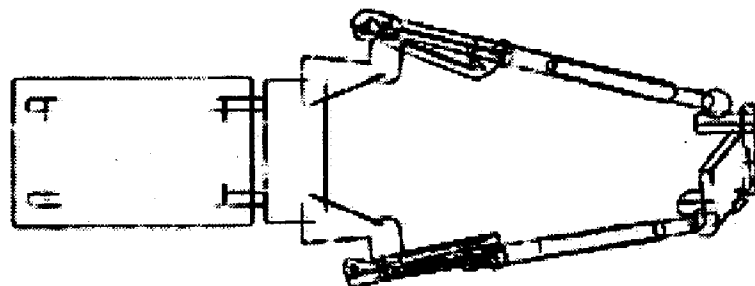
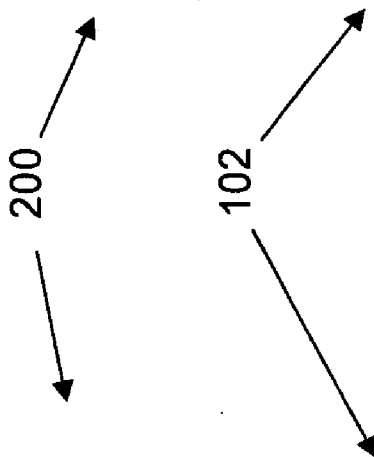

FIGURE 26B

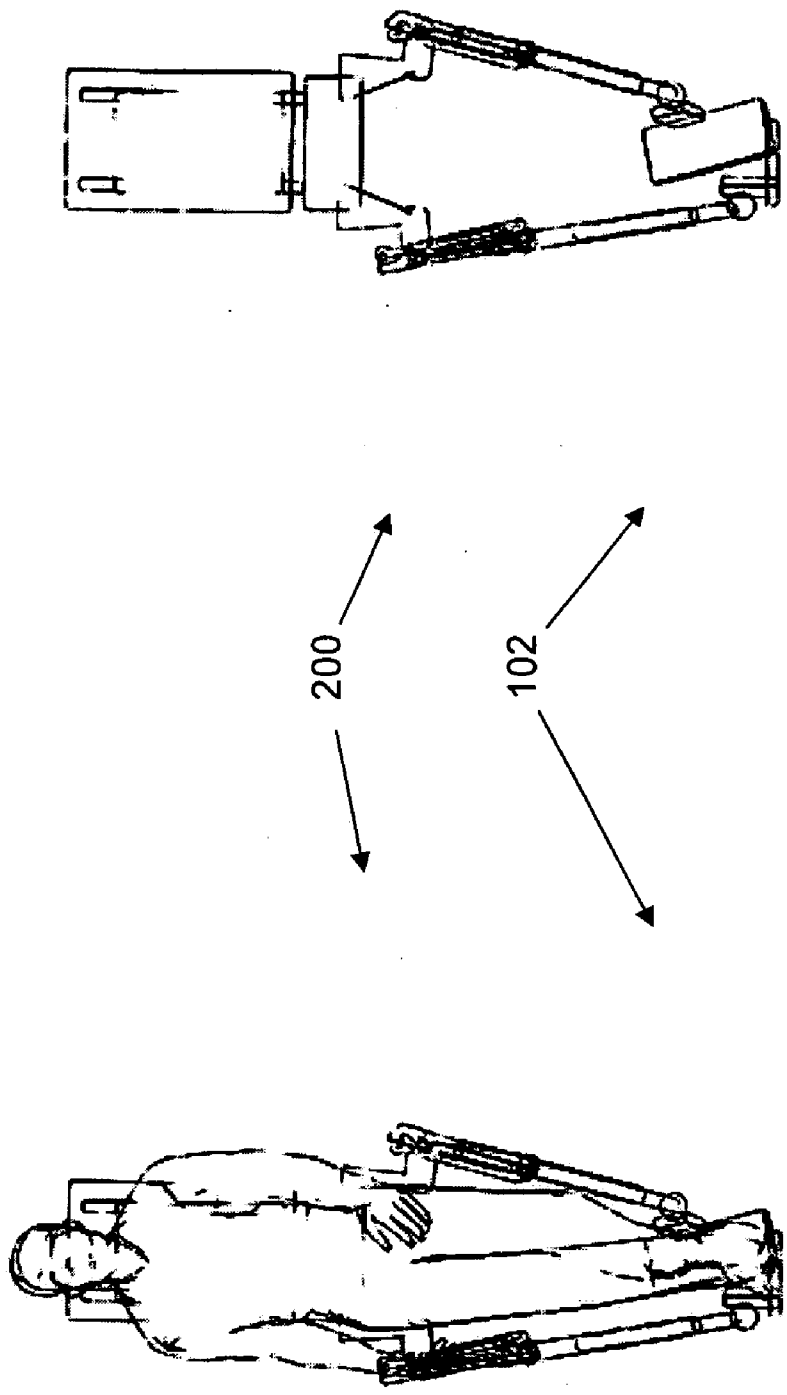

FIGURE 27B

FIGURE 27A

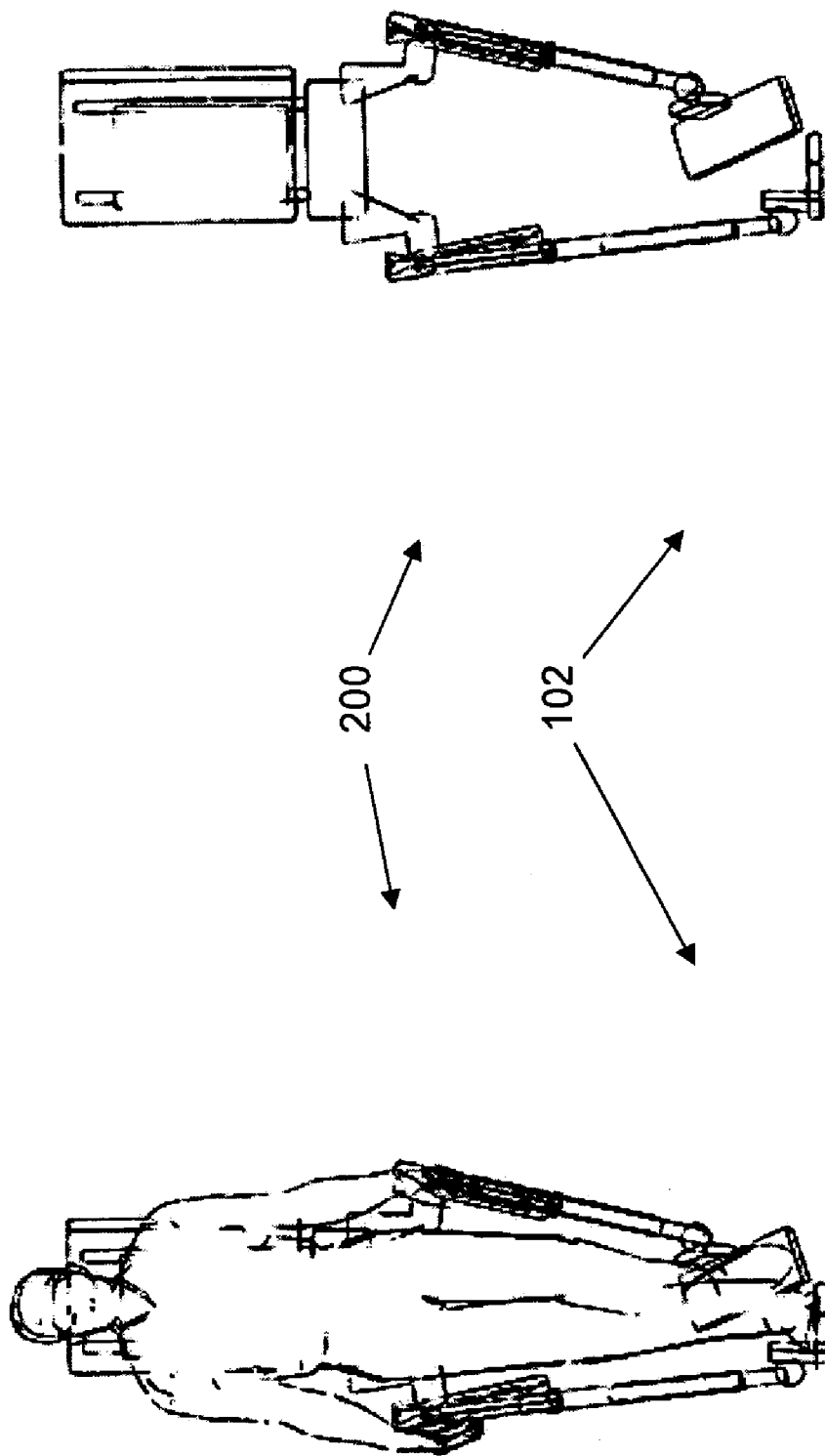

FIGURE 28B

FIGURE 28A

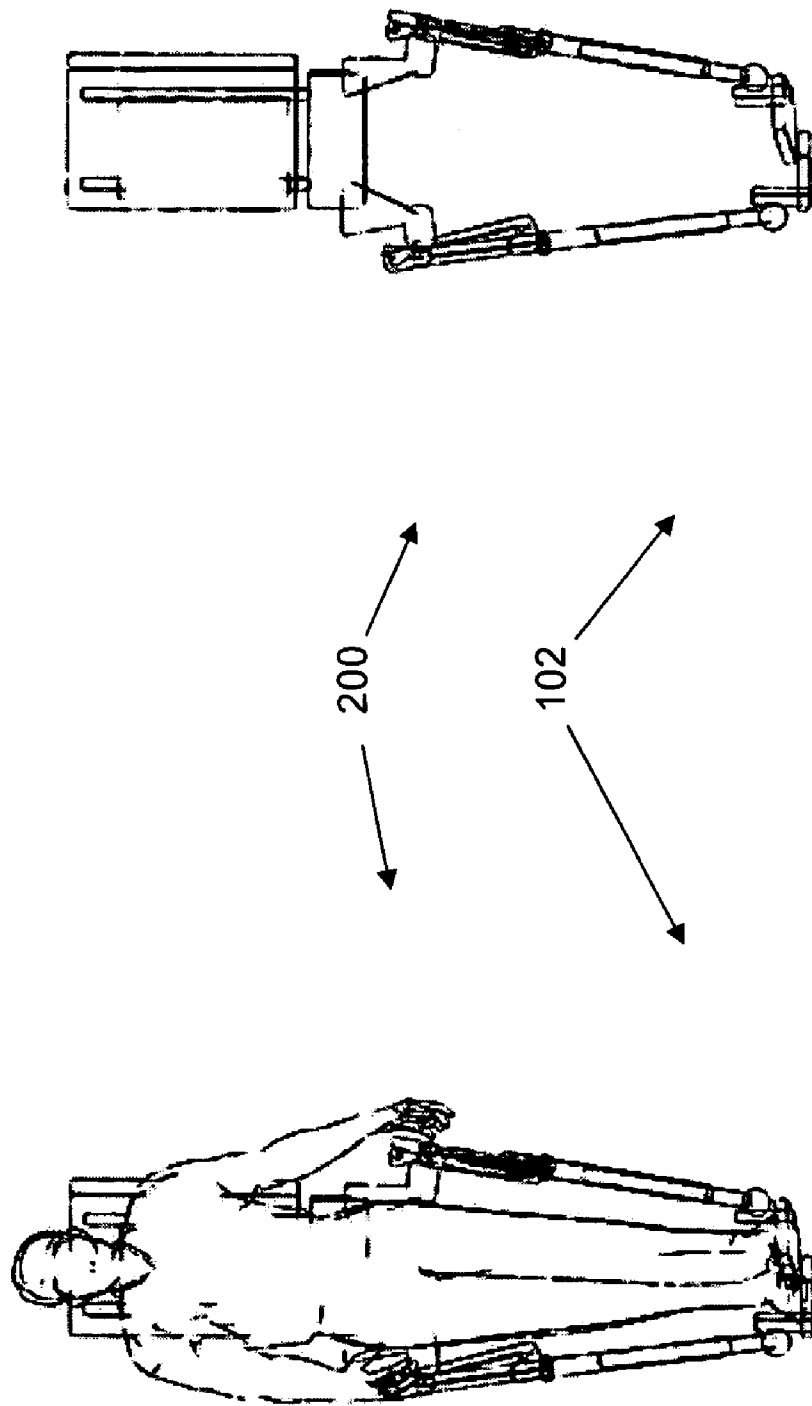

FIGURE 29B

FIGURE 29A

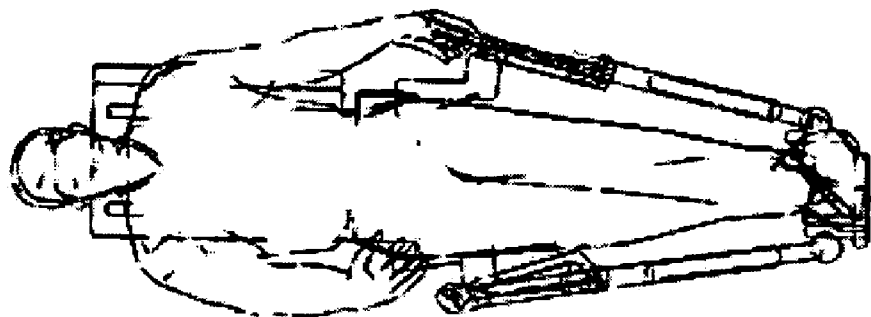

FIGURE 30A

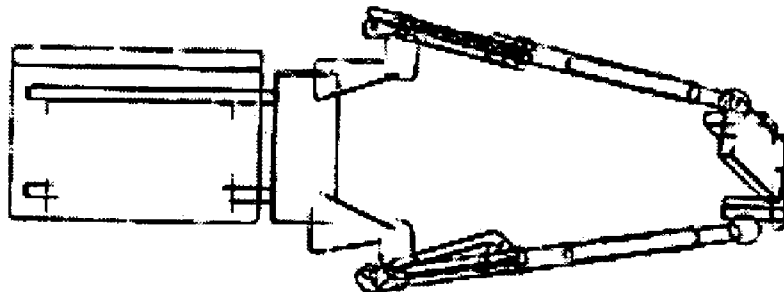
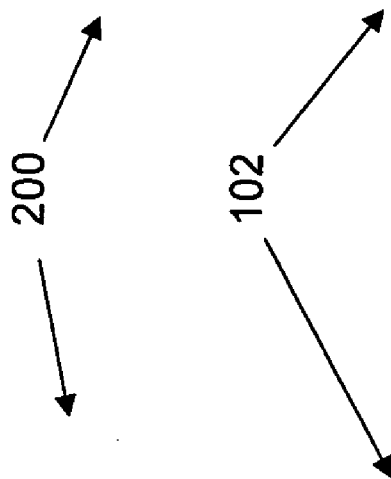

FIGURE 30B

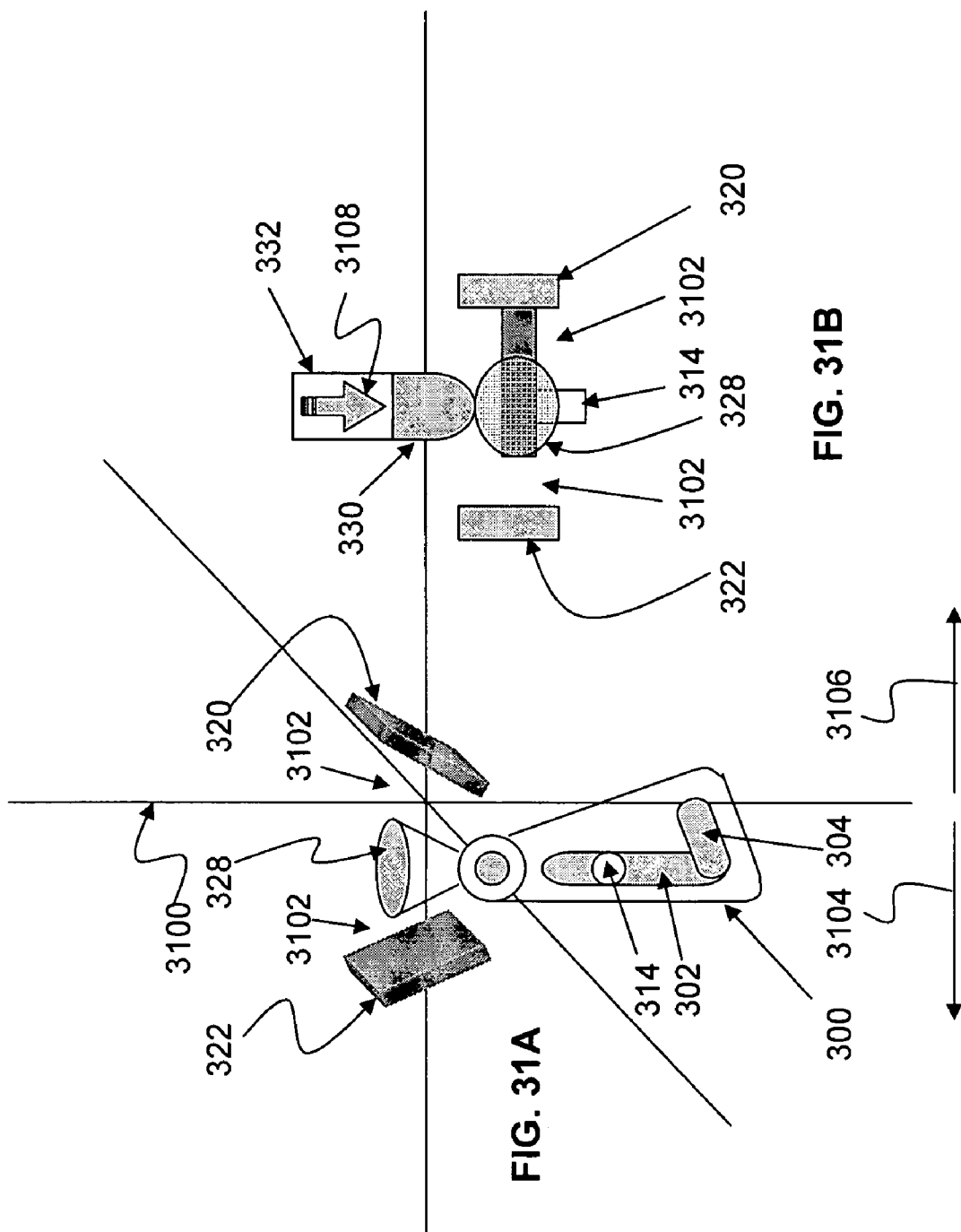

FIG. 31A

FIG. 31B

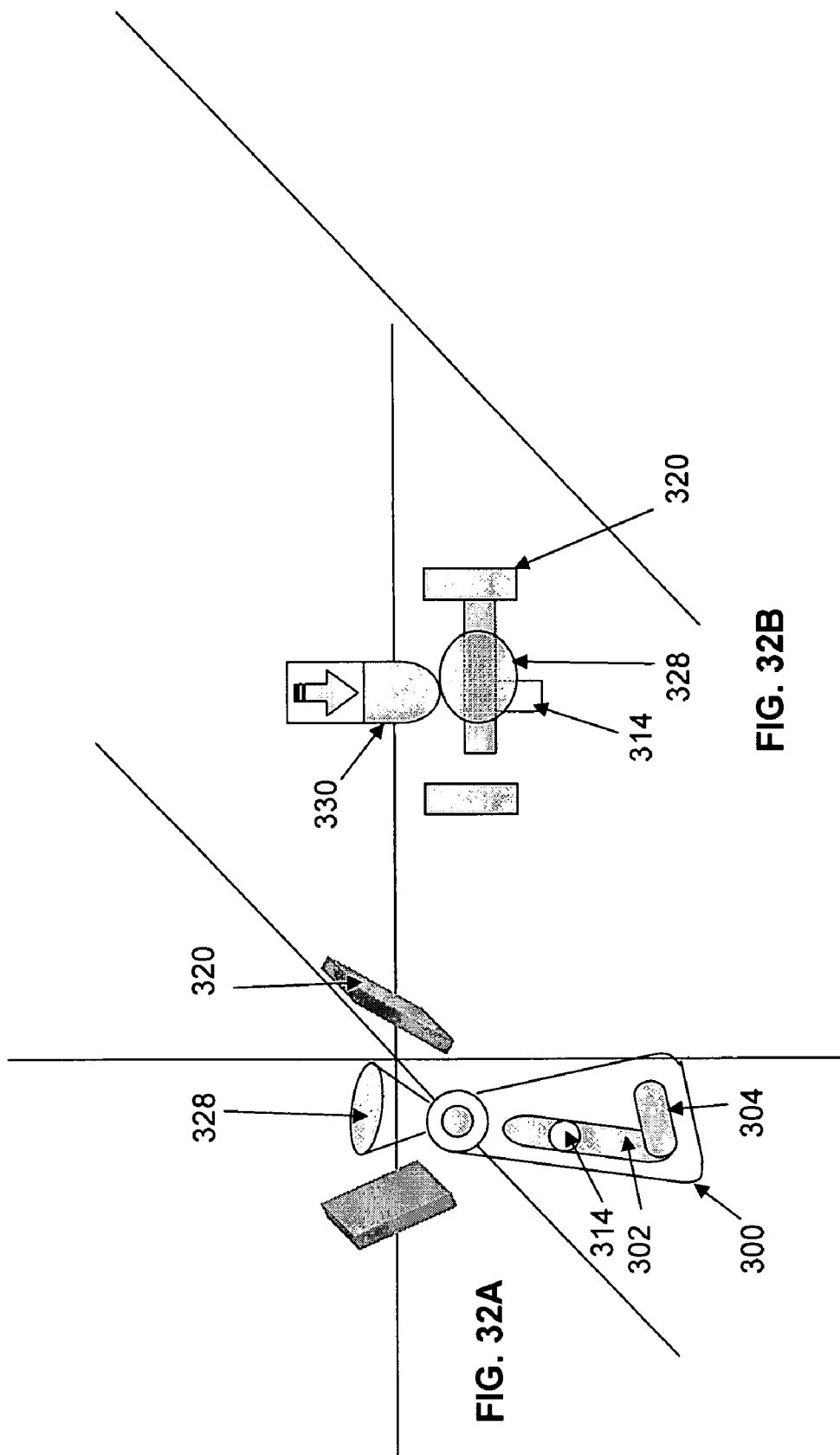

FIG. 32A

FIG. 32B

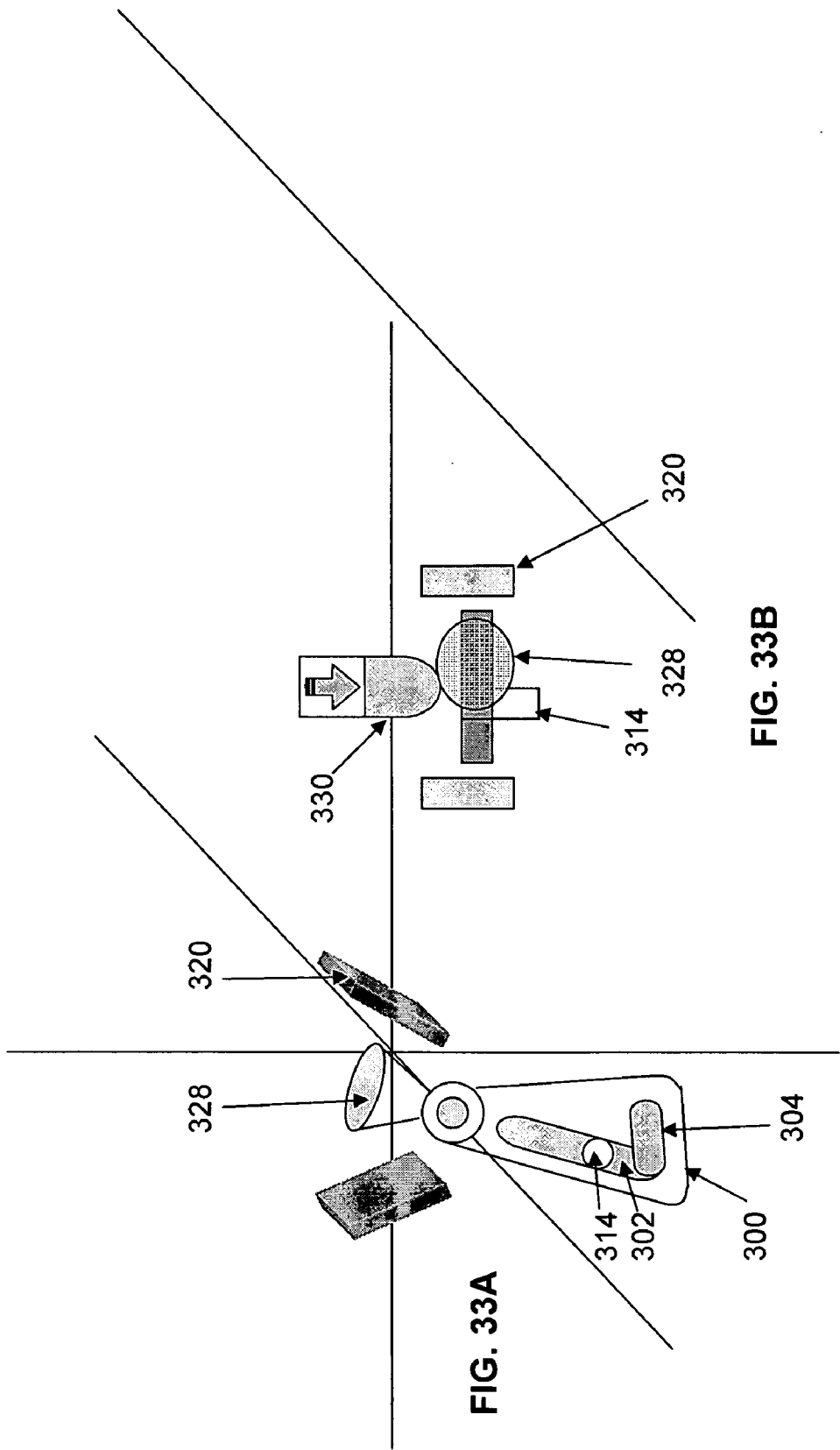

FIG. 33A

FIG. 33B

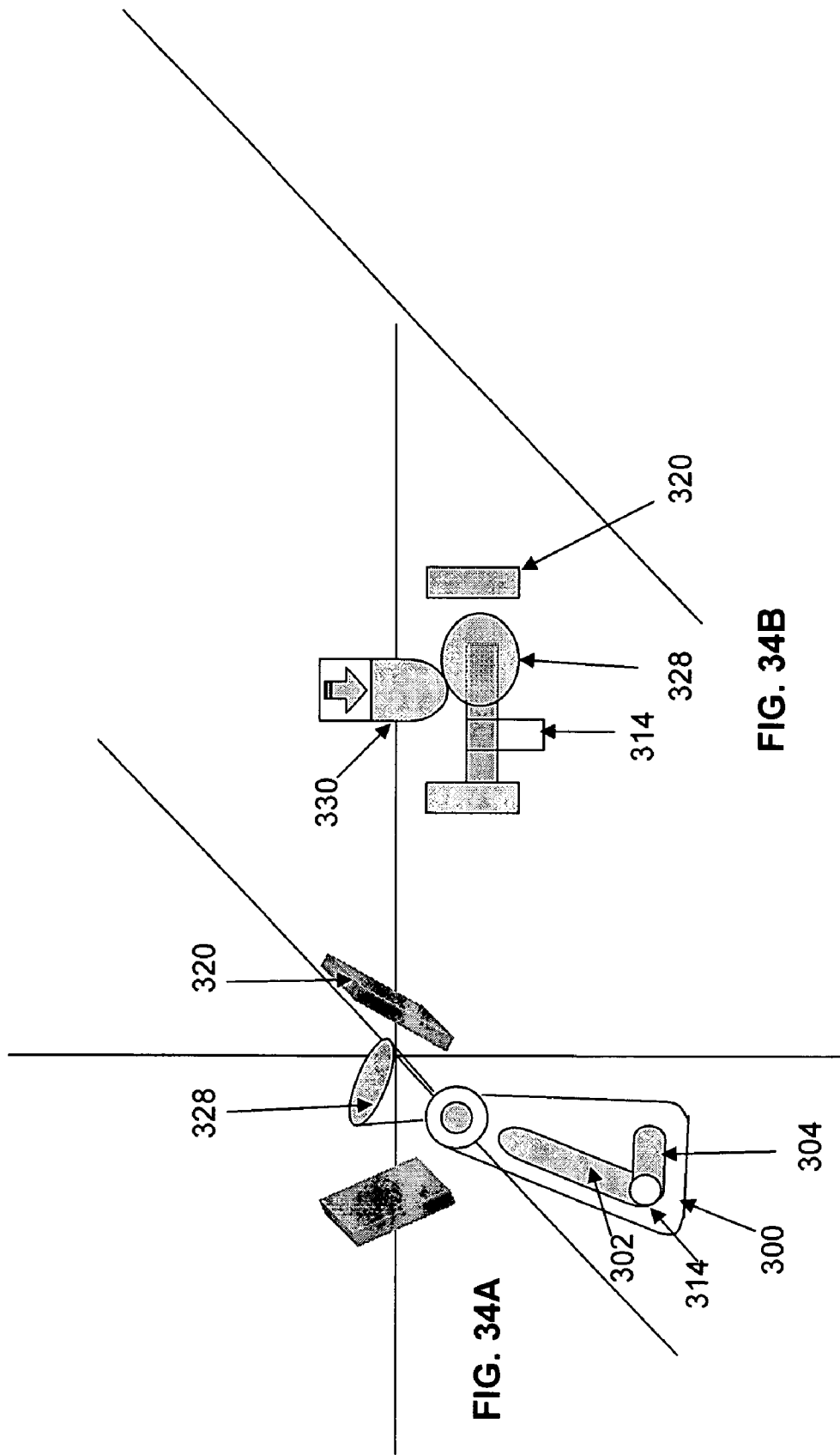
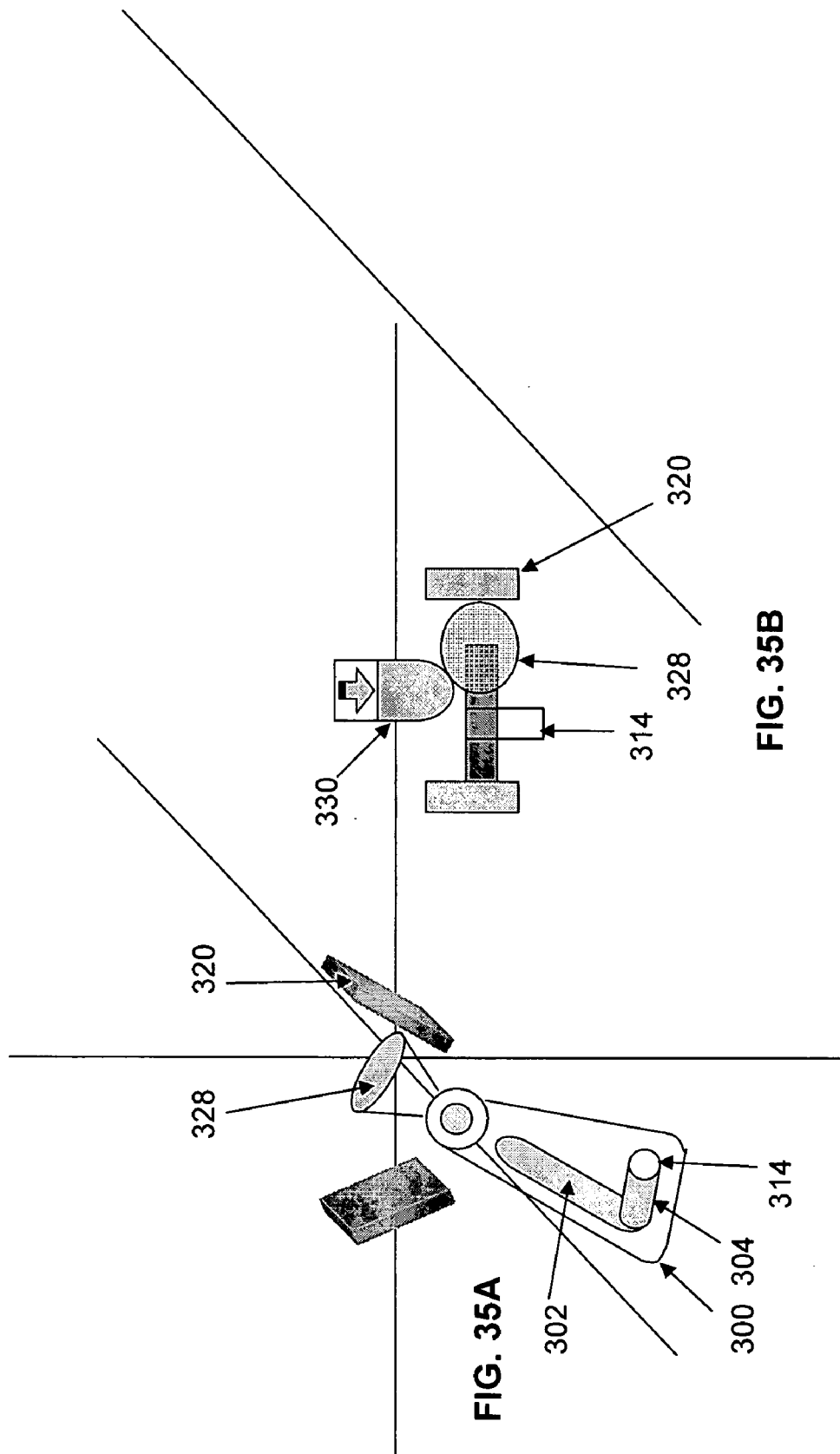

FIG. 34A

FIG. 34B



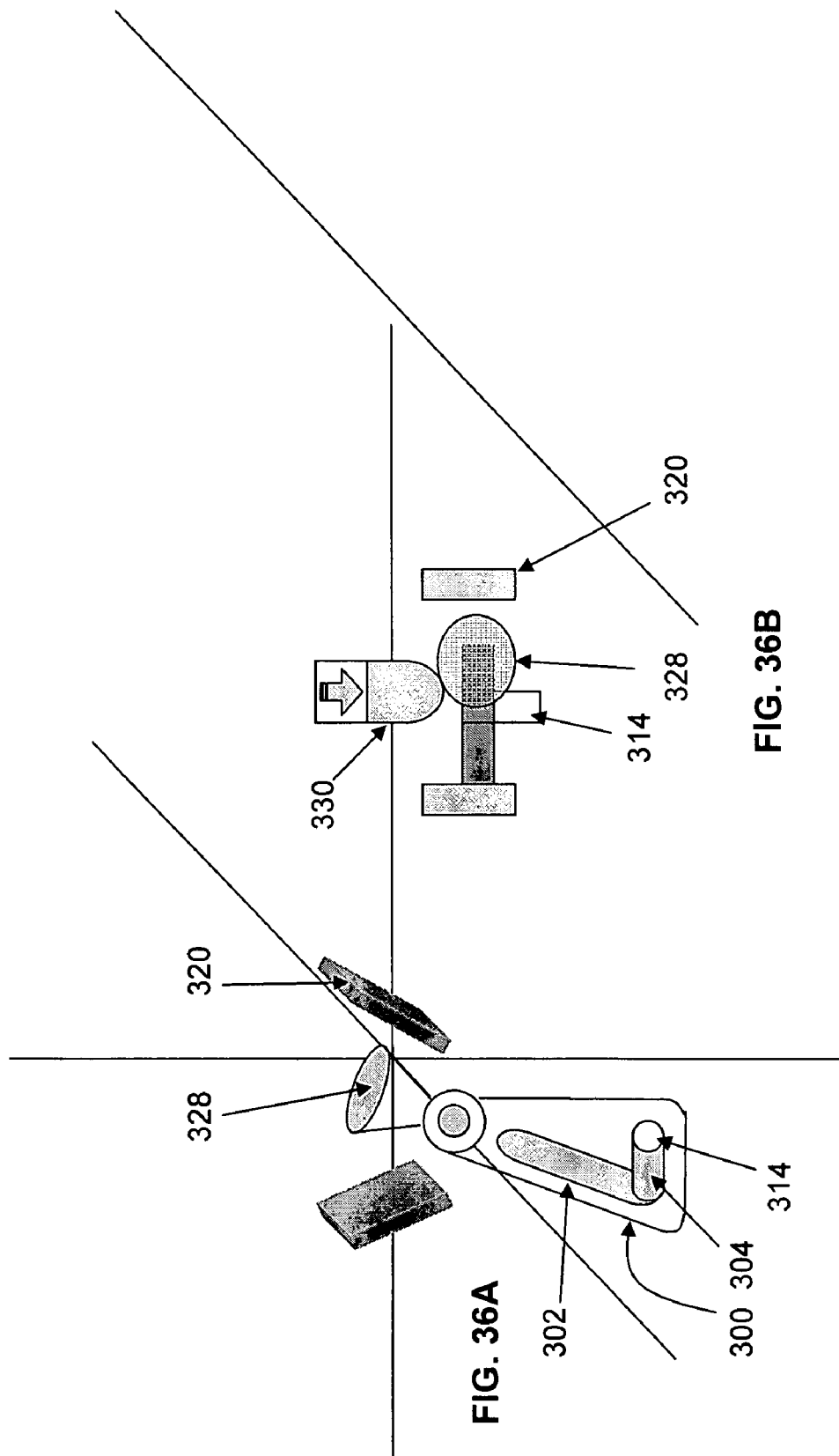

FIG. 36A

FIG. 36B

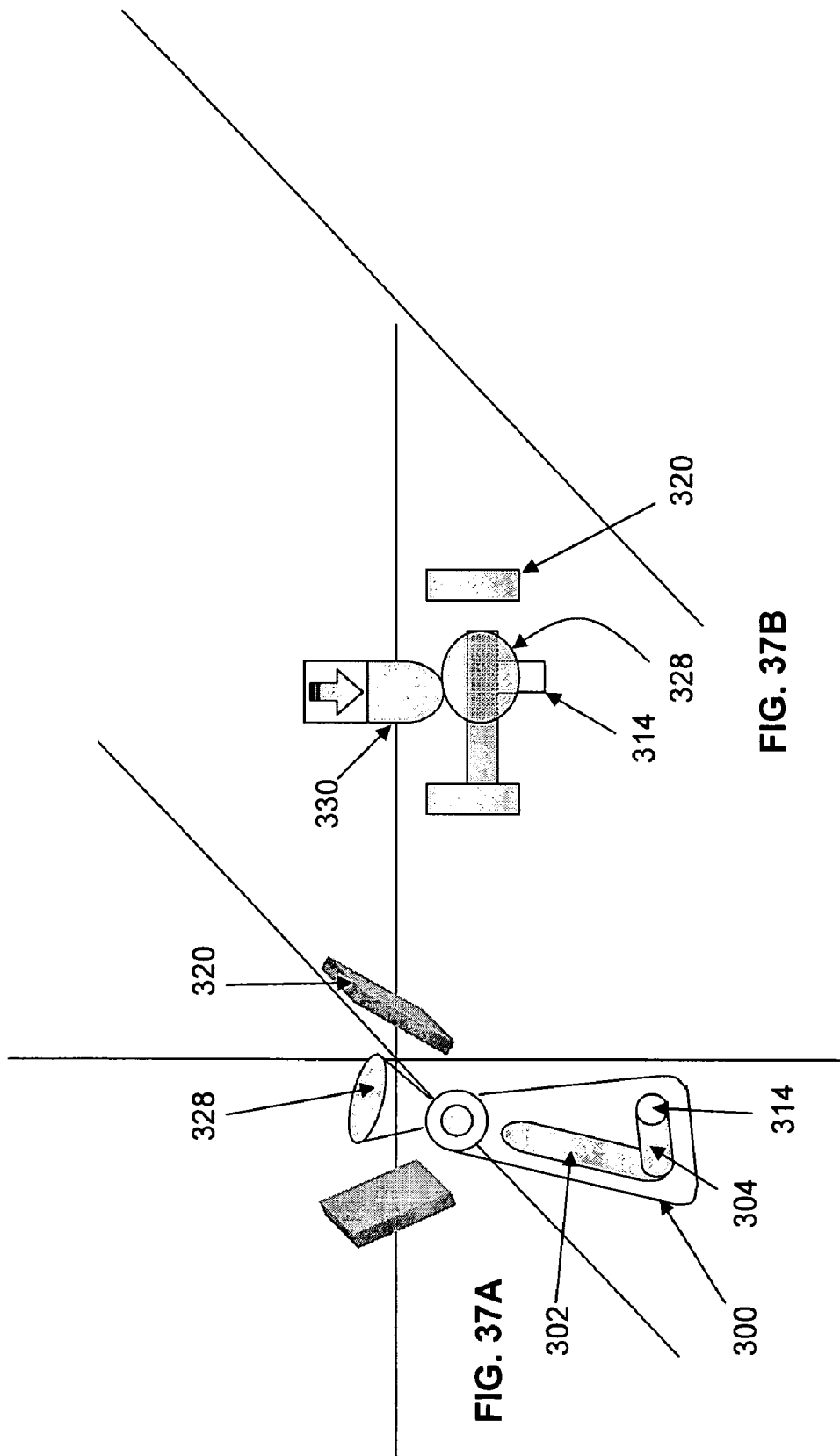

FIG. 37A

FIG. 37B

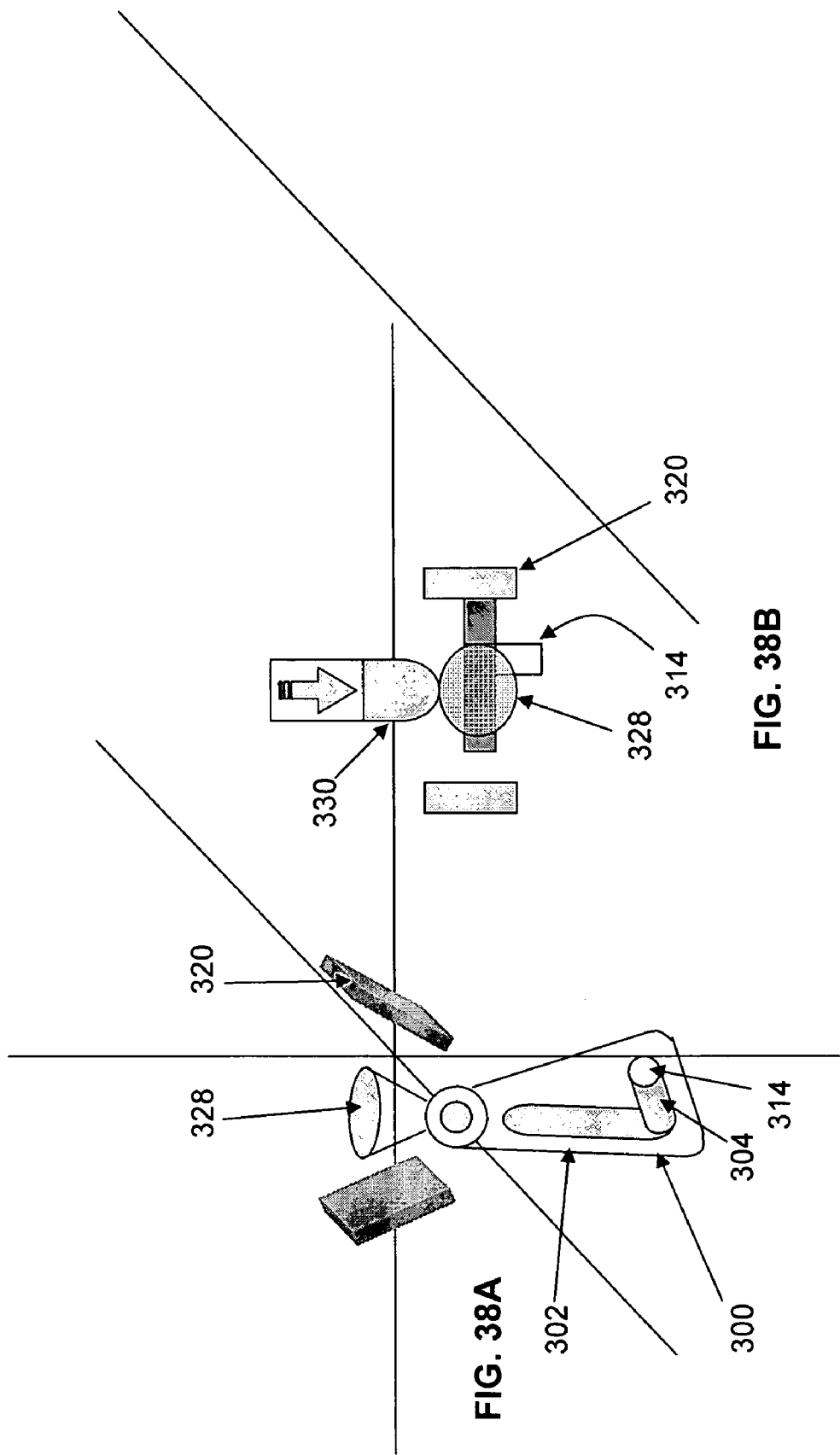

FIG. 38A

FIG. 38B

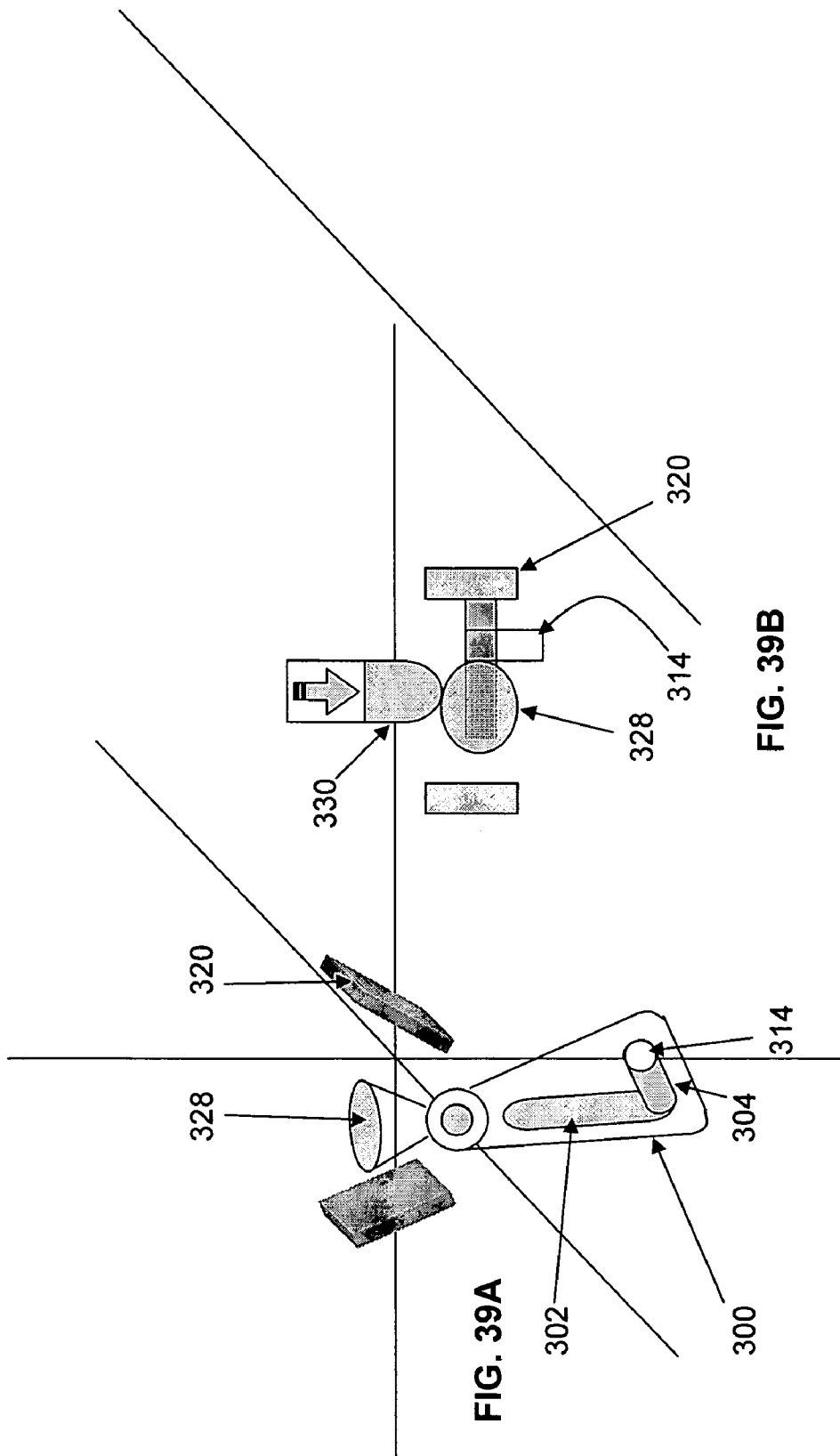

FIG. 39A

FIG. 39B

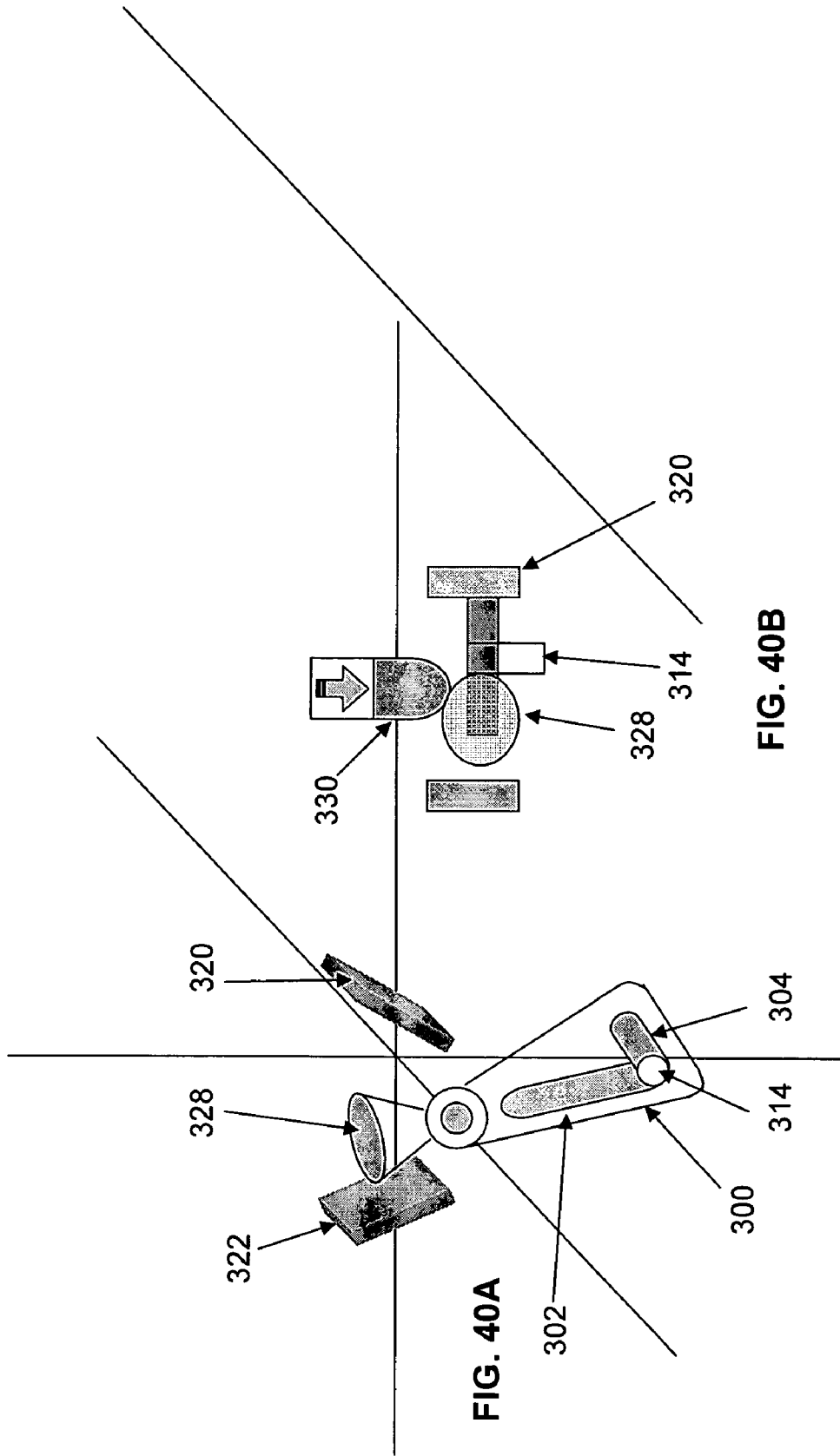

FIG. 40A

FIG. 40B

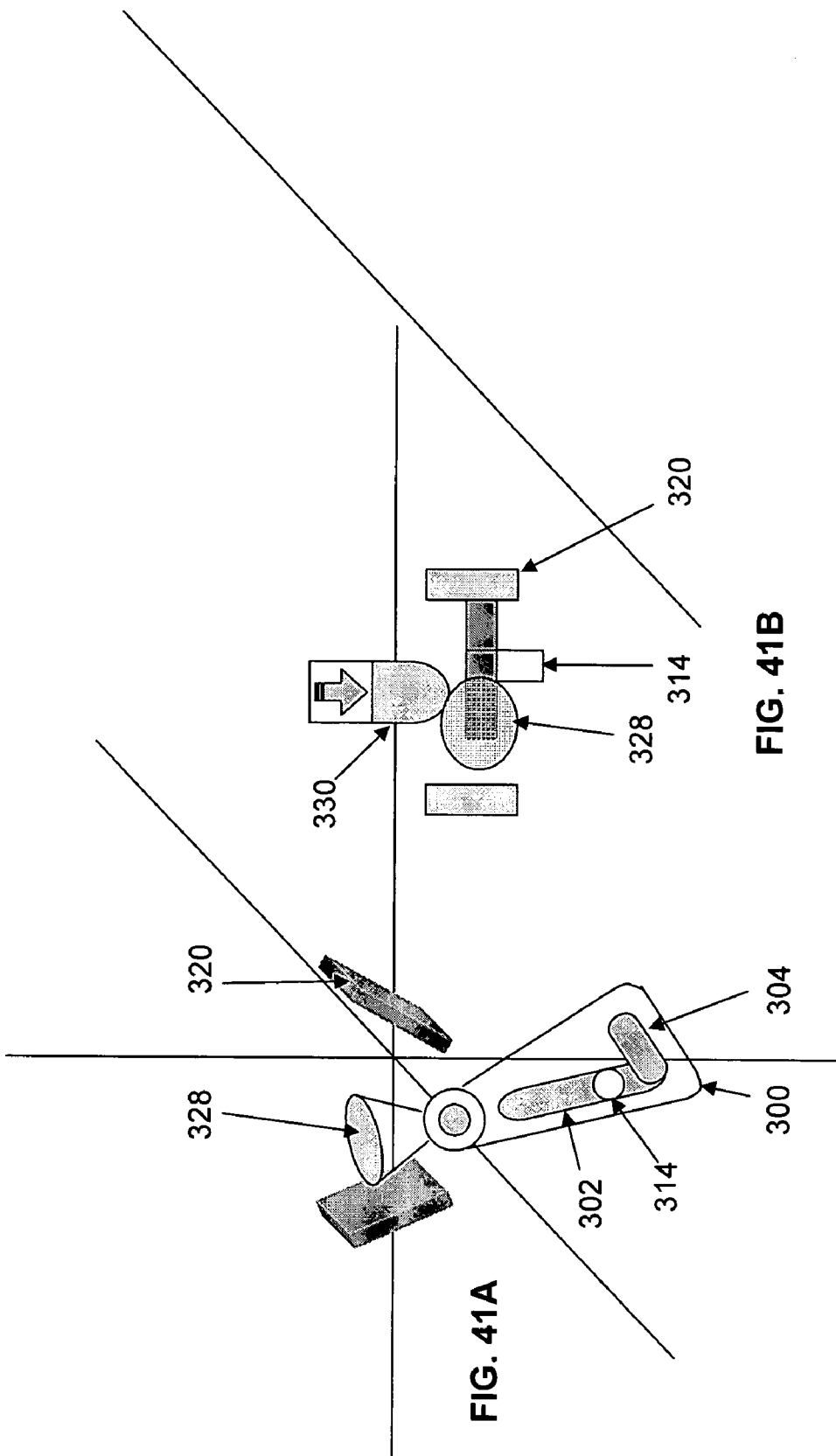

FIG. 41A

FIG. 41B

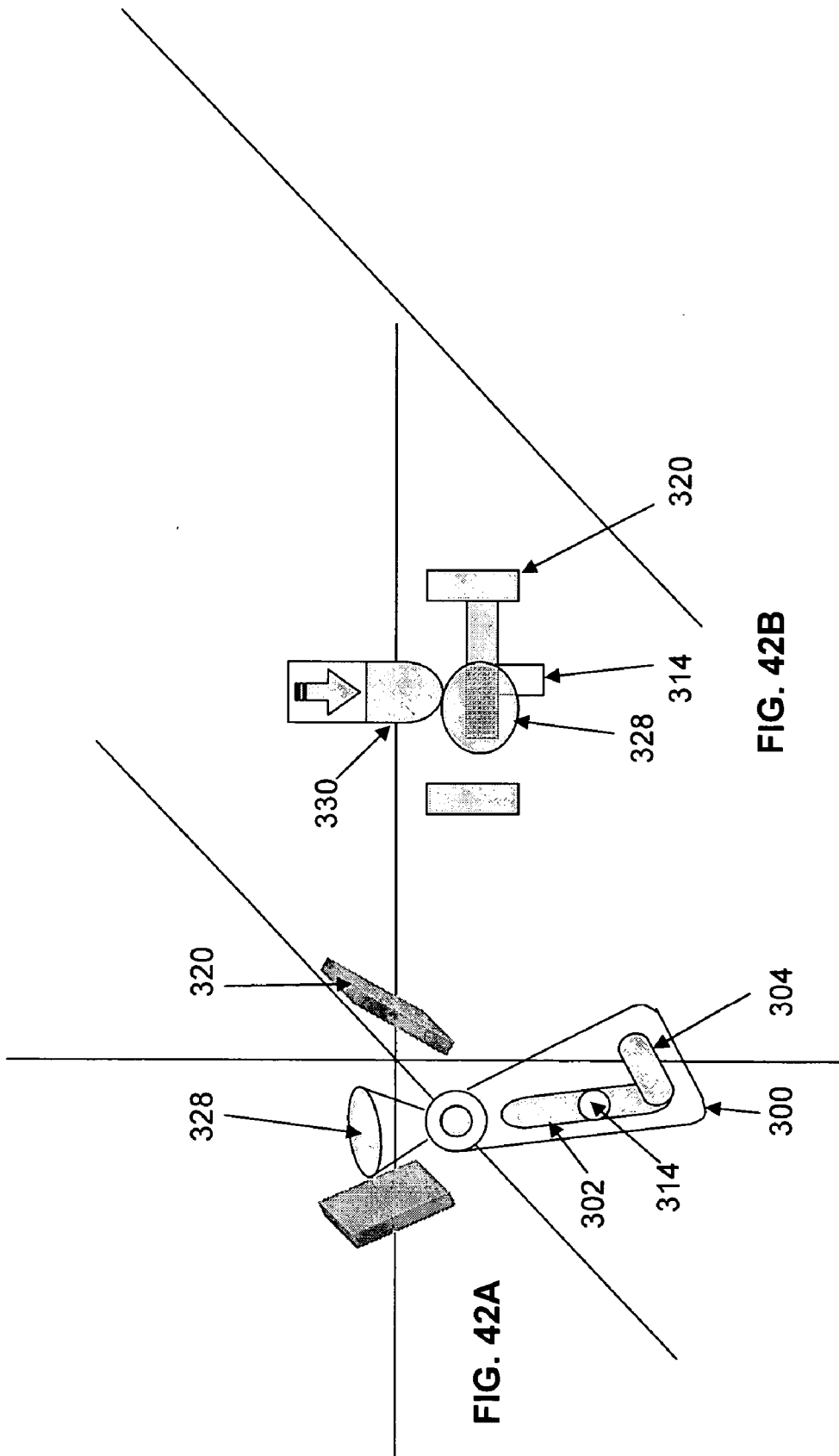

FIG. 42A

FIG. 42B

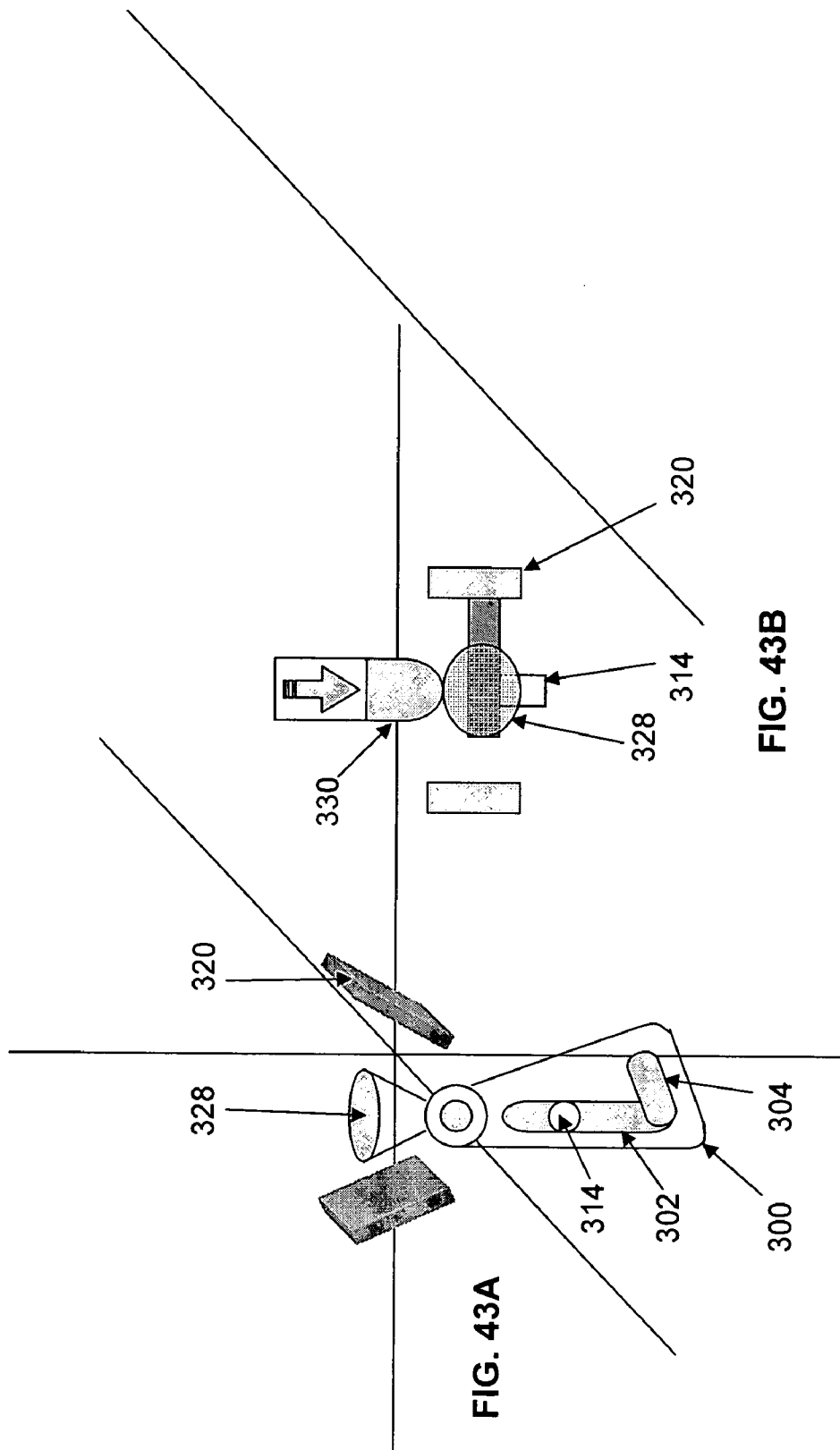

FIG. 43A

FIG. 43B

PASSIVE EXOSKELETON

PRIORITY CLAIM

[0001] This application is a Continuation-In-Part application, claiming the benefit of priority to non-provisional application Ser. No. 10/850,202, filed in the United States on May 19, 2004, and titled "Passive Exoskeleton."

BACKGROUND OF INVENTION

[0002] (1) Field of Invention

[0003] The present invention relates to a load-bearing apparatus, and more particularly to a passive exoskeleton onto which a load may be placed, with the weight of the load transferred from the passive exoskeleton to a ground surface, causing the passive exoskeleton to support at least a portion of the load.

[0004] (2) Background of Invention

[0005] Load bearing devices have long been known in prior art. For example, backpacks with frames have long been employed to reduce a load carried by an individual's shoulders. Although the backpack functions to distribute the load, the weight of the load is transferred to the individual's hips, forcing the individual to ultimately bear the burden of the load. Because of the necessity to bear the burden of the load, the amount of weight an individual may carry using a traditional backpack is limited.

[0006] Other examples of load-bearing devices include orthopedic devices such as canes, crutches, and walkers. Although orthopedic devices transfer the load to the ground, they generally are designed under an assumption that the user must be able to stand and carry his/her own weight. Many orthopedic devices require the user's upper torso to be continuously used and such devices generally are not useful when upper limbs must remain free and unoccupied.

[0007] Another example of an orthopedic device is disclosed in U.S. Pat. No. 6,015,076, issued to Pennington ("the Pennington patent"). The Pennington patent discloses a hip belt which reduces fatigue by bridging across muscles and nerves in the gluteal region. A drawback of devices made according to this particular prior art is that all of the weight is still carried by the individual's skeletal and muscular system.

[0008] In an effort to reduce the load placed on the user's skeletal and muscular system, powered exoskeletons have been proposed. Powered exoskeletons mimic the function of body joints by using actuators or artificial muscles. The actuators required for these exoskeleton concepts consume significant power, supplies for which are either difficult to produce or are currently unavailable. Additionally, the compact actuator (artificial muscle) technology has currently not progressed enough to make practical devices. As such, the development of a powered exoskeleton requires further developments in a variety of fields, including actuation, artificial muscles, and advanced energy storage. Given the current state of these technologies, powered exoskeletons may not be realized for decades to come.

[0009] In an effort to provide an exoskeleton without a power system, the applicant of the present invention previously devised a passive exoskeleton. The passive exoskeleton comprises a rigid body member for attaching proximate

a portion of a user's body, a rocker pivotally attached with the body member, a sliding rod attached with the rocker, and a ground surface engage-able foot analog attached with the sliding rod. The rocker has both a load channel and a travel channel, while a load pin attached with the sliding rod travels between the load and travel channels as a user walks. As a user places a load on the body member and walks forward, weight of the load is transferred from the body member, through the rocker's load channel, onto the load pin and its sliding rod. Thereafter, weight from the load passes into the foot analog, causing the passive exoskeleton to support at least a portion of the load. Rocker stops are attached with the body member, such that when a user is in a full stride gait, the rocker continues its motion until it hits the rocker stops at the limit of its travel. The rocker stops aid the load pin in transferring between the load and travel channels at the appropriate times during the user's forward gait. Although functional for forward motion, the problem with such a configuration is that it does not work as well for backwards (i.e., reverse) motion. With a single load channel, the rocker stops alone are not sufficient to aid in transferring the load pin between the load and travel channels when a user is traveling backwards.

[0010] Thus, it can be appreciated that there exists a continuing need for a passive exoskeleton that permits a user to walk both forward and backwards, such that in either direction, the load pin travels between the load and travel channels at the appropriate times during a user's gait. The present invention substantially fulfills this need.

SUMMARY OF INVENTION

[0011] The present invention relates to a load bearing apparatus, and more particularly, to a passive exoskeleton whereby a load may be placed on the passive exoskeleton and thereby transfer weight of the load from the passive exoskeleton to a ground surface.

[0012] The passive exoskeleton comprises a body member for attaching proximate a portion of a user's body; a sliding rod attached with the body member; a ground surface engage-able foot analog attached with the sliding rod; a rocker pivotally attached with the body member; a load pin attached with the sliding rod; and a bias block attached with the body member.

[0013] The rocker has a travel channel and a load channel incorporated therein. The travel channel is an elongated channel oriented directionally from proximate the body member to the ground surface. The load channel is formed as an elongated channel and positioned such that an angle between the load channel and the travel channel is less than ninety degrees. The rocker also includes a top component.

[0014] A load pin is attached with the sliding rod and operably attached with the rocker through both the travel channel and the load channel. The load pin is formed such that as a user walks and shifts from a swing phase to a stance phase, the load is transferred from the body member to the rocker, the shift causing the load pin to travel between the travel channel and the load channel.

[0015] A bias block is attached with the body member for engaging with the top component of the rocker. Both the bias block and the top component of the rocker are formed in such a manner such that as a user walks backwards and shifts

between the swing phase and stance phase, the top component of the rocker passes a point of equilibrium where the bias block turns the rocker to aid the load pin in transferring between the load channel and travel channel, thereby shifting the load from the rocker onto the sliding rod and thereafter through the sliding rod to the foot analog and ultimately a ground surface, causing the passive exoskeleton to support at least a portion of the load.

[0016] In another aspect, the passive exoskeleton further comprises a pressure mechanism attached with the bias block for forcing the bias block against the top component of the rocker, thereby aiding the bias block in turning the rocker after the top component of the rocker passes the point of equilibrium. The pressure mechanism is selected from a group consisting of a spring and hydraulics.

[0017] The passive exoskeleton further comprises a neutral block attached with the passive exoskeleton. The neutral block is formed in such a manner that it is engage-able with the rocker to prevent the rocker from moving, such that when engaged with the rocker and when the load pin is in the travel channel, the load pin is maintained in the travel channel and is unable to transfer to the load channel, thereby causing the user to bear the full weight of the load.

[0018] In yet another aspect, the passive exoskeleton further comprises a front rocker stop and a rear rocker stop. The front rocker stop and the rear rocker stop are attached with the body member. Additionally, the rocker further comprises a top component for engaging with both the front and rear rocker stops. The top component and rocker stops are formed such that when a user is walking, the rocker travels from a forward position to a rear position, and when the rocker is in a forward position, the top component engages with the rear rocker stop, and when the rocker is in a rear position, the top component engages with the front rocker stop.

[0019] In another aspect, the sliding rod further comprises an alignment rod and a load rod. The alignment rod has a top portion, a bottom portion, and a length with an axis there-through. The top portion of the alignment rod is pivotally attached with the body member. The load rod is in a fixed parallel alignment with the axis of the alignment rod. The load rod has a top part and a bottom part, where the load rod is connected with the alignment rod such that a length of the sliding rod is adjustable by sliding the top part of the load rod between the bottom portion and top portion of the alignment rod. Furthermore, the load pin is attached with the load rod, whereby as a user walks and shifts from a swing phase to a stance phase, the load is transferred from the body member to the rocker. The shift causes the load pin to travel between the travel channel and the load channel, thereby shifting the load from the rocker onto the load pin and thereafter through the load rod and the foot analog to the ground surface.

[0020] In yet another aspect, the body member is rigid, allowing the passive exoskeleton to transfer weight from the body member and through the passive exoskeleton to the ground surface.

[0021] Additionally, the load rod further comprises an ankle joint attached with the bottom part of the load rod, where the ankle joint pivotally connects the load rod with the foot analog.

[0022] In another aspect, the rocker has a first side and a second side, and both the travel channel and the load channel are formed through the rocker from the first side to the second side.

[0023] Additionally, the present invention further comprises a foot connector attached with the foot analog, whereby a user may utilize the foot connector to securely attach the foot analog with the user's foot or shoe, thereby allowing the foot analog to maintain a position proximate the user's foot.

[0024] In yet another aspect, the present invention further comprises a body attachment attached with the body member. The body attachment is selected from a group consisting of a flexible harness, a belt, and suspenders. The body attachment is for attaching with a torso portion of a user, allowing the user to operate the exoskeleton and maintain the exoskeleton in a position proximate the user.

[0025] Additionally, the present invention further comprises a load frame attached with the body member, whereby a user may attach a load with the load frame and thereby transfer weight from the load, through the exoskeleton and to the ground surface.

[0026] Finally, it can be appreciated by one in the art that the present invention also comprises a kit and method for forming and supporting a load using the apparatus described herein.

BRIEF DESCRIPTION OF THE DRAWINGS

[0027] The nature of the passive exoskeleton described herein will be readily apparent with reference to the description below, taken in conjunction with the following drawings, in which:

[0028] **FIG. 1** is an illustration of gait kinematics, illustrating a stance phase and a swing phase of an individual's gait;

[0029] **FIG. 2** is an illustration of a perspective view of a passive exoskeleton according to the present invention;

[0030] **FIG. 3** is an illustration of a perspective view of a rocker according to the present invention;

[0031] **FIG. 4** is an illustration of a magnified, perspective view of a rocker according to the present invention, illustrating a position of a load pin in relation to the rocker during a stance phase;

[0032] **FIG. 5** is an illustration of a magnified, perspective view of a rocker according to the present invention, illustrating a position of the load pin in relation to the rocker during another stance phase;

[0033] **FIG. 6** is an illustration of a magnified, perspective view of a rocker according to the present invention, illustrating a position of the load pin in relation to the rocker during still another stance phase;

[0034] **FIG. 7** is an illustration of a magnified, perspective view of a rocker according to the present invention, illustrating a position of the load pin in relation to the rocker during yet another stance phase;

[0035] **FIG. 8** is an illustration of a magnified, perspective view of a rocker according to the present invention, illus-

trating a position of the load pin in relation to the rocker during a further stance phase;

[0036] FIG. 9 is an illustration of a magnified, perspective view of a rocker according to the present invention, illustrating a position of the load pin in relation to the rocker during a swing phase;

[0037] FIG. 10 is an illustration of a magnified, perspective view of a rocker according to the present invention, illustrating a position of the load pin in relation to the rocker during another swing phase;

[0038] FIG. 11 is an illustration of a magnified, perspective view of a rocker according to the present invention, illustrating a position of the load pin in relation to the rocker during still another swing phase;

[0039] FIG. 12 is an illustration of a magnified, perspective view of a rocker according to the present invention, illustrating a position of the load pin in relation to the rocker during an end of the swing phase;

[0040] FIG. 13A is an illustration of a perspective view of a passive exoskeleton attached with a user, where a right leg of a user is in an initial contact of a stance phase;

[0041] FIG. 13B is an illustration of the passive exoskeleton in the position shown in FIG. 13A, without the user;

[0042] FIG. 14A is an illustration of a perspective view of a passive exoskeleton attached with a user, where a right leg of a user is in a loading response of another stance phase;

[0043] FIG. 14B is an illustration of the passive exoskeleton in the position shown in FIG. 14A, without the user;

[0044] FIG. 15A is an illustration of a perspective view of a passive exoskeleton attached with a user, where a right leg of a user is in a mid-stance of the stance phase;

[0045] FIG. 15B is an illustration of the passive exoskeleton in the position shown in FIG. 15A, without the user;

[0046] FIG. 16A is an illustration of a perspective view of a passive exoskeleton attached with a user, where a right leg of a user is in a terminal stance of the stance phase;

[0047] FIG. 16B is an illustration of the passive exoskeleton in the position shown in FIG. 16A, without the user;

[0048] FIG. 17A is an illustration of a perspective view of a passive exoskeleton attached with a user, where a right leg of a user is in a pre-swing of a stance phase;

[0049] FIG. 17B is an illustration of the passive exoskeleton in the position shown in FIG. 17A, without the user;

[0050] FIG. 18A is an illustration of a perspective view of a passive exoskeleton attached with a user, where a right leg of a user is in an initial swing of the swing phase;

[0051] FIG. 18B is an illustration of the passive exoskeleton in the position shown in FIG. 18A, without the user;

[0052] FIG. 19A is an illustration of a perspective view of a passive exoskeleton attached with a user, where a right leg of a user is in a mid-swing of the swing phase;

[0053] FIG. 19B is an illustration of the passive exoskeleton in the position shown in FIG. 19A, without the user;

[0054] FIG. 20A is an illustration of a perspective view of a passive exoskeleton attached with a user, where a right leg of a user is in an initial swing of the swing phase;

[0055] FIG. 20B is an illustration of the passive exoskeleton in the position shown in FIG. 20A, without the user;

[0056] FIG. 21A is a side view illustration of a passive exoskeleton attached with a user, where a right leg of a user is in an initial contact of the stance phase;

[0057] FIG. 21B is an illustration of the passive exoskeleton in the position shown in FIG. 21A, without the user;

[0058] FIG. 22A is a side view illustration of a passive exoskeleton attached with a user, where a right leg of a user is in a loading response portion of the stance phase;

[0059] FIG. 22B is an illustration of the passive exoskeleton in the position shown in FIG. 22A, without the user;

[0060] FIG. 23A is a side view illustration a passive exoskeleton attached with a user, where a right leg of a user is in a mid-stance of the stance phase;

[0061] FIG. 23B is an illustration of the passive exoskeleton in the position shown in FIG. 23A, without the user;

[0062] FIG. 24A is a side view illustration a passive exoskeleton attached with a user, where a right leg of a user is in a terminal stance of the stance phase;

[0063] FIG. 24B is an illustration of the passive exoskeleton in the position shown in FIG. 24A, without the user;

[0064] FIG. 25A is a side view illustration of a passive exoskeleton attached with a user, where a right leg of a user is in a pre-swing of the stance phase;

[0065] FIG. 25B is an illustration of the passive exoskeleton in the position shown in FIG. 25A, without the user;

[0066] FIG. 26A is front view illustration of a passive exoskeleton attached with a user, where a right leg of a user is in an initial contact of the stance phase;

[0067] FIG. 26B is an illustration of the passive exoskeleton in the position shown in FIG. 26A, without the user;

[0068] FIG. 27A is a front view illustration of a passive exoskeleton attached with a user, where a right leg of a user is in a loading response of the stance phase;

[0069] FIG. 27B is an illustration of the passive exoskeleton in the position shown in FIG. 27A, without the user;

[0070] FIG. 28A is a front view illustration of a passive exoskeleton attached with a user, where a right leg of a user is in a mid-stance of the stance phase;

[0071] FIG. 28B is an illustration of the passive exoskeleton in the position shown in FIG. 28A, without the user;

[0072] FIG. 29A is a front view of a passive exoskeleton attached with a user, where a right leg of a user is in a terminal-stance of the stance phase;

[0073] FIG. 29B is an illustration of the passive exoskeleton in the position shown in FIG. 29A, without the user;

[0074] FIG. 30A is a side view illustration of a passive exoskeleton attached with a user, where a right leg of a user is in a pre-swing of the stance phase;

[0075] FIG. 30B is an illustration of the passive exoskeleton in the position shown in FIG. 30A, without the user;

[0076] FIG. 31A is a side view illustration of a rocker according to the present invention, shown in a recovery phase;

[0077] FIG. 31B is a top view illustration of the rocker of FIG. 31A, engaging with a bias block according to the present invention;

[0078] FIG. 32A is a side view illustration of a rocker according to the present invention, shown in the recovery phase;

[0079] FIG. 32B is a top view illustration of the rocker of FIG. 32A, engaging with a bias block according to the present invention;

[0080] FIG. 33A is a side view illustration of a rocker according to the present invention, shown in the recovery phase;

[0081] FIG. 33B is a top view illustration of the rocker of FIG. 33A, engaging with a bias block according to the present invention;

[0082] FIG. 34A is a side view illustration of a rocker according to the present invention, showing a transition from the recovery phase to a stance phase;

[0083] FIG. 34B is top view illustration of the rocker of FIG. 34A, engaging with a bias block according to the present invention;

[0084] FIG. 35A is a side view of illustration of a rocker according to the present invention, shown in the stance phase;

[0085] FIG. 35B is a top view illustration of the rocker of FIG. 35A, engaging with a bias block according to the present invention;

[0086] FIG. 36A is a side view illustration of a rocker according to the present invention, shown in the stance phase;

[0087] FIG. 36B is a top view illustration of the rocker of FIG. 36A, engaging with a bias block according to the present invention;

[0088] FIG. 37A is a side view illustration of a rocker according to the present invention, shown in the stance phase;

[0089] FIG. 37B is a top view illustration of the rocker of FIG. 37A, engaging with a bias block according to the present invention;

[0090] FIG. 38A is a side view illustration of a rocker according to the present invention, shown in the stance phase;

[0091] FIG. 38B is a top view illustration of the rocker of FIG. 38A, engaging with a bias block according to the present invention;

[0092] FIG. 39A is a side view illustration of a rocker according to the present invention, shown in the stance phase;

[0093] FIG. 39B is a top view illustration of the rocker of FIG. 39A, engaging with a bias block according to the present invention;

[0094] FIG. 40A is a side view illustration of a rocker according to the present invention, showing a transition from the stance phase to a swing phase;

[0095] FIG. 40B is a top view illustration of the rocker of FIG. 40A, engaging with a bias block according to the present invention;

[0096] FIG. 41A is a side view illustration of a rocker according to the present invention, shown in the swing phase;

[0097] FIG. 41B is a top view illustration of the rocker of FIG. 41A, engaging with a bias block according to the present invention;

[0098] FIG. 42A is a side view illustration of a rocker according to the present invention, shown in the swing phase;

[0099] FIG. 42B is a top view illustration of the rocker of FIG. 42A, engaging with a bias block according to the present invention;

[0100] FIG. 43A is a side view illustration of a rocker according to the present invention, shown in a recovery phase after the rocker has returned to a quasi-equilibrium position; and

[0101] FIG. 43B is top view illustration of the rocker of FIG. 43A, engaging with a bias block according to the present invention.

DETAILED DESCRIPTION

[0102] The present invention relates to a load bearing apparatus, and more particularly to a passive exoskeleton that permits a load to be placed on the passive exoskeleton for at least a portion of the weight of the load to be transferred directly from the passive exoskeleton to a ground surface, causing the passive exoskeleton to support at least a portion of the load.

[0103] The following description, taken in conjunction with the referenced drawings, is presented to enable one of ordinary skill in the art to make and use the invention. Various modifications will be readily apparent to those skilled in the art, and the general principles defined herein may be applied to a wide range of aspects. Thus, the present invention is not intended to be limited to the aspects presented, but is to be accorded the widest scope consistent with the principles and novel features disclosed herein. Furthermore, it should be noted that unless explicitly stated otherwise, the figures included herein are illustrated qualitatively and without any specific scale, and are intended to generally present the concept of the present invention.

[0104] In order to provide a clear frame of reference, first a glossary of terms used in the description and claims is given as a central resource for the reader. Next, a description of gait kinematics is provided to give an understanding of motion as applicable to the present invention. Third, a detailed description is provided to give specific details of the present invention. Finally, a description of the present invention during various motions is provided to further illustrate the utility of the present invention.

[0105] (1) Glossary

[0106] Before describing the specific details of the present invention, a central location is provided in which various terms used herein and in the claims are defined. The glossary provided is intended to provide the reader with a general understanding for the intended meaning of the terms, but is not intended to convey the entire scope of each term. Rather, the glossary is intended to supplement the rest of the specification in more clearly explaining the terms used.

[0107] Bias Block—The term “bias block” refers to a mechanism or device attached with a body member for engaging with a top component of a rocker, such that as a user walks backwards and shifts between the swing phase and stance phase, the top component of the rocker passes a point of equilibrium, with the bias block turning the rocker to aid the load pin in transferring between a load channel and a travel channel. The bias block is overridden when normal (i.e., forward) locomotion occurs.

[0108] Exoskeleton—The term “exoskeleton” refers to a load bearing apparatus for attaching with a user.

[0109] Foot-Analog—The term “foot-analog” refers to a structure or device that is similar to a human foot in that it is engageable with a ground surface and may be used for transferring weight to the ground surface.

[0110] Gait Kinematics—The term “gait kinematics” refers to body mechanics associated with walking or stepping.

[0111] (2) Gait Kinematics

[0112] The present invention relates to a load-bearing passive exoskeleton. In order to better understand the invention, some introductory remarks are provided to help explain gait kinematics. As shown in **FIG. 1**, the gait cycle **100** can be divided into two phases: a stance phase **102** and a swing phase **104**. As shown in **FIG. 1**, the stance phase **102** accounts for approximately sixty percent (60%) of the gait cycle **100** during walking. It starts at heel-strike (initial contact) **106** and ends at toe-off (pre-swing) **108**. The swing phase **104** accounts for approximately 40% of the gait cycle **100** and is when the limb is not loaded. So, for example, when one limb is in a loading response **110**, the other limb is in a pre-swing **108**.

[0113] In order for the passive exoskeleton to function properly, two fundamental criteria should be met: (1) a rod (brace) should support a load during the stance phase **102**, but not inhibit motion during the swing phase **104**, and (2) the rod (brace) must allow a normal range of motion, while comfortably supporting a load.

[0114] There are a number of ways that such a structure could support a load. One possibility is to have a rigid rod that maintains a fixed distance between a hip **114** and an ankle **116**. Since a user's knee **118** would be locked in this case (i.e., it doesn't bend), the user would be forced to walk unnaturally, with unbending knees. Although the rod could hold part of the weight of the load, such a device would be uncomfortable because of this “unbent knee” problem.

[0115] Another possibility would be to have two rods connected by a hinge joint at the knee **118**. A problem with this, however, is that a hinge cannot support weight by itself. In this case, a user would need to use leg muscles acting at

the knee **118** to prevent falling. Similarly, a hinged brace would require a muscle or actuator to mimic the function of the knee **118**. Such a system, however, is not practical using current actuator technologies. Instead of adding complexity and requiring self-contained power to drive these actuators, the present invention pursues a different strategy, to create a simple device that requires no electrical power.

[0116] One possible passive solution would be to use a spring at the hinged knee joint. The spring could take up part of the load and act as the constant muscle for the knee joint. Adding a spring would allow some bending of the knee **118** and better gait kinematics. A problem with this approach, however, is that the system should carry the load during the stance phase **102**, but not resist the leg force during the swing phase **104** (when the leg is swinging forward and is not supporting the weight). Otherwise, the benefit in having the device support the load during the stance phase **102** of the stride would be negated during the swing phase **104** of the stride. In this example, any time the knee **118** is bent, force must be exerted to compress the spring. After heel-strike **106**, during the stance phase **102** of the gait cycle **100**, a spring would be desirable because the weight of the load is used to compress the spring. However, after toe-off and during the swing phase **104**, the spring is undesirable because the user must use considerable force to bend the knee **118** and bring up the heel **119** to allow the toe **120** to clear the ground during the swing phase **104**. During the swing phase **104**, the user would be “fighting the spring.”

[0117] Another possible solution is to have one rigid rod between the hip **114** and ankle **116**, but to allow the user's knee **118** to bend. The difficulty with this solution is that when the user's knee **118** bends, the distance between the hip **114** and ankle **116** varies. With a single rod, this would result in the rod protruding above the user's hip **114** when the knee **118** is bent. In this configuration, the load may be attached with the end of the rod to allow its weight to be transferred to the rod. Therefore, the load would bounce up and down during walking. Furthermore, this system would still require the user to lift the entire weight of the load when bring up their heel, similar to the “fighting the spring” problem previously described.

[0118] The solution proposed by the present invention decouples the stance **102** and swing **104** phases of walking. This allows the exoskeleton to bear a load during the stance phase **102**, but to bear substantially no load during the swing phase **104** (recovery), so the individual does not fight the device when swinging a leg forward. This can be accomplished through use of the exoskeleton described herein. Since the distance between the hip **114** and ankle **116** is also allowed to vary, the knee **118** can be bent and the user does not have the “unbent knee” problem. On the other hand, the rod bears no load during the swing phase **104** (recovery) so there is no “fighting the spring” problem. In addition, a mechanism at the ankle **116** allows the weight of the load to be transferred to a ground surface and eliminates the need for the user to exert extra effort to lift their ankle **116** during the swing phase **104**. The details of the exoskeleton described herein are further described below.

[0119] (3) Description

[0120] **FIG. 2** illustrates a passive exoskeleton **200** according to the present invention. The exoskeleton **200** comprises a body member **202** for transferring weight of a

load **204** to a sliding rod **205**, and thereafter to a ground surface **206**. Additionally, a load frame **207** may be attached with the body member **202**, thereby allowing the load **204** to be secured with the exoskeleton **200**. The body member **202** may be any suitable mechanism for transferring and bearing weight, non-limiting examples of which include a rigid plate and a rigid hip attachment. For example, the rigid hip attachment may be a metallic bar that wraps around a user's hip. In this aspect, the weight of the load **204** would be transferred to the metallic bar, and thereafter through the connected sliding rod **205** and on to the ground surface **206**.

[0121] Additionally, a body attachment **208** may be attached with the body member **202**. The body attachment **208** is for attaching the exoskeleton **200** with a torso portion of a user, allowing the user to operate the exoskeleton **200** and maintain the exoskeleton **200** in a position proximate the user. The body attachment **208** may be any suitable mechanism or device for maintaining one object proximate another, non-limiting examples of which include a flexible harness, a belt, and suspenders.

[0122] The sliding rod **205** is attached with the body member **202**. The sliding rod **205** is constructed of any suitably rigid material, a non-limiting example of which includes metal, plastic, and composite materials. The sliding rod **205** comprises

[0123] an alignment rod **212** and a load rod **214**. The alignment rod **212** has a top portion **216**, a bottom portion **218**, and a length with an axis **220** there-through. The alignment rod **212** may be any suitable mechanism or device for maintaining an alignment of an object, non-limiting examples of which include a cylindrical tube, an elongated plate, a rod, and a metallic bar. The top portion **216** of the alignment rod **212** is attached with the body member **202** through a mechanism that allows movement therebetween, a non-limiting example of which includes being pivotally attached through use of a pin, or ball joint such as a hip joint.

[0124] The load rod **214** is in a fixed parallel alignment with the axis **220** of the alignment rod **212**. The load rod **214** is a mechanism or device for bearing a load, non-limiting examples of which include a cylindrical tube, an elongated plate, a rod, and a metallic bar. The load rod **214** has a top part **222** and a bottom part **224**, and is connected with the alignment rod **212** such that a length of the sliding rod **205** is adjustable by sliding the top part **222** of the load rod **214** between the bottom portion **218** and top portion **216** of the alignment rod **212**. As a non-limiting example, the alignment rod **212** is a cylindrical tube and is positioned within a larger cylindrical tube of the load rod **214**, allowing the two rods to be slid past each other, thereby varying the length of the sliding rod **205**.

[0125] In order to transmit the weight of the load **204** to the ground, the load rod **214** must be connected to something in contact with the ground. This is accomplished through use of a ground surface engage-able foot analog **226** that is attached with the bottom part **224** of the load rod **214**. The foot analog **226** is attached with the load rod **214** through a suitable mechanism or device allowing movement therebetween, a non-limiting example of which includes being pivotally attached through use of an ankle joint **228**. The foot analog **226** is constructed such that it is engageable with

both a ground surface and with a user's foot. As a non-limiting example, the foot analog **226** may be a platform for connecting with a bottom side of a user's shoe.

[0126] If the load rod **214** was only attached to the user's boot at the ankle with no foot analog **226**, during toe-off the user would need to use a calf muscle to lift up the heel and thus the entire weight of the load **204**. Having to lift the entire weight of the load **204** at each toe-off would be difficult to do and could present a significant mechanical burden. By using a foot analog **226** such as a platform, the load rod **214** is able to support the weight of the load **204** and transmit it to the ground without requiring additional effort from the user's calf muscle.

[0127] A foot connector **230** is attached with the foot analog **226**, allowing a user to securely attach the foot analog **226** with the user's foot or shoe, thereby allowing the foot analog **226** to maintain a position proximate the user's foot. The foot connector **230** may be any suitable mechanism or device for fastening one object against another, non-limiting examples of which include Velcro™ straps, clips, and buckles.

[0128] A user's leg can only support a load during the stance phase. For example, a user has two legs and as the user walks, each leg shifts between the stance and swing phases. While one leg is substantially in the swing phase, the other leg is substantially in the stance phase. Accordingly, during the swing phase, the other leg is supporting the load as it is in the stance phase. Therefore, the exoskeleton further comprises a rocker **300**, as shown in FIG. 3. The rocker **300** helps support the weight of a load during the stance phase, but does not inhibit motion during the swing phase. The rocker **300** is attached with the body member **202** through a mechanism or device allowing movement therebetween, a non-limiting example of which includes being pivotally attached through use of a hip pin or a ball joint. The rocker **300** has a travel channel **302** and a load channel **304** incorporated therein. Furthermore, both the travel channel **302** and the load channel **304** pass through the rocker **300** from a first side **306** to a second side **308**.

[0129] The travel channel **302** is an elongated channel constructed such that it is oriented directionally from proximate the body member **202** to the ground surface **206**. The load channel **304** is an elongated channel positioned such that an angle **312** between the load channel **304** and the travel channel **302** is less than ninety degrees.

[0130] A load pin **314** is attached with the top part **222** of the load rod **214**. The load pin **314** is positioned such that it is operably attached with the rocker **300** through both the travel channel **302** and the load channel **304**. When the load pin **314** is in the travel channel **302**, the two rods can slide relative to one another and substantially no weight is carried by that particular rocker **300**.

[0131] When a user walks and shifts from a swing phase to a stance phase, the shift causes the load pin **314** to travel down **315** the travel channel **302** and into the load channel **304**, thereby shifting the load from the rocker **300**, onto the load pin **314**, and thereafter through the load rod **214** and the foot analog to the ground surface **206**.

[0132] The body member **202** has a front side **316** and a rear side **318**. A front rocker stop **320** is attached with the front side **316** of the body member **202** and a rear rocker stop

322 is attached with the rear side **318** of the body member **202**. When a user is walking, the rocker **300** swings between a forward position **324** and a rear position **326**. When the rocker is in a forward position **324**, a top component **328** of the rocker **300** engages with the rear rocker stop **322**. When the rocker **300** is in a rear position **326**, the top component **328** engages with the front rocker stop **320**.

[0133] A bias block **330** is attached with the body member **202** to divide the region between the two rocker stops **320/322**. Without the bias block **330**, the rocker **300** has no interaction at its top component **328** until it hits the rocker stops **320/322** at the limit of its travel in a full stride gait. To aid the bias block **330** in interacting with the top component **328**, a pressure mechanism **332** is attached with the bias block **330**. The pressure mechanism **332** is attached with the bias block in a suitable manner to force the bias block **330** against the top component **328** of the rocker **300**. As a non-limiting example, the pressure mechanism **332** is placed between the body member **202** and the bias block **330**, and is a mechanism with suitable expansion and contraction properties. As non-limiting examples of suitable mechanisms, the pressure mechanism **332** may be a spring or hydraulic system forcing the bias block **330** against the top component **328**. For example, if a hydraulic system, a hydraulic mechanism (e.g., such as a shock similar to those used in automobiles) may be attached with the bias block **330** to force it against the top component **328**, such that as the top component **328** moves, the hydraulic system adjusts itself to continually force the bias block **330** into the top component **328**.

[0134] The bias block **330** serves to rotate the rocker **300** such that the load pin **314** is moved from the load channel **304** to the travel channel **302**, or back. The pressure applied by the bias block **330** against the top component **328** of the rocker **300** (i.e., via the pressure mechanism **332**) is sufficient to rotate the rocker **300** either clockwise or counter clockwise when the stride/gait shifts the load off the load pin **314**. When under load, the load pin **314** will be locked in the load channel **304** and the bias block **330** will not be able to rotate the rocker **300**.

[0135] The bias block **330** rotates the rocker **300** in the same direction as the top is inclined (with respect to the quasi-equilibrium point). This means when walking backwards, the top of the rocker is inclined clockwise as the user steps backward. As the load pin **314** reaches the intersection of the load **304** and travel channels **302**, the bias block **330** further rotates the rocker **300** clockwise which moves the load pin **314** from the travel channel **302** into the load channel **304**. This works in the same way as the user (still walking backwards) goes into the recovery part of the stride and lifts up their foot (having shifted the weight off that leg onto the other), with the bias block **330** rotating the rocker **300** counterclockwise to move the load pin **314** from the load channel **304** into the travel channel **302**, permitting the user to lift their foot without opposition of the passive exoskeleton **200**.

[0136] Further, the bias block **330** can be angled to permit vertical engagement when taking stairs either upward or downward. Ascent techniques depend on proper bias block **330** angle and a proper travel channel **302** length (i.e., minimum length must exceed the height of a stair step). However, the stair ascent is a matter of technique. The

important part is the bias block **330** which permits the rocker **300** to engage and disengage during the gait. Details of the stair ascent or descent are dependent on the particular configuration (i.e., orientation) of the bias block **330**.

[0137] For example, the bias block **330** assumes a smaller step backward than forward, where the rocker stops must be set far enough apart to provide the bias block **330** with sufficient space to function. The bias block **330** function is dependent on the orientation of the load channel **304** to the travel channel **302**. Thus, if the rocker **300** were flipped, and the load channel **304** were to head in the opposite direction, then small steps forward would be enabled by the bias block **330** and large steps backward by the rocker stops.

[0138] To neutralize (i.e., turn off) the passive exoskeleton, a neutral block **334** is attached with the top portion **216** of the alignment rod **212**. The neutral block **334** is configured such that it is engage-able with the top component **328** of the rocker **300**. When the load pin is in the travel channel, the rocker is aligned with the sliding rods **205** and, more particularly, with the alignment rod **212**. An engaging portion **336** (a non-limiting example of which includes a slot) exists in the top component **328** of the rocker **300**, such that when the engaging portion **336** is engaged between the alignment rod **212** and the top component **328** (i.e., when directly aligned), the rocker **300** will remain aligned with the sliding rod **205**. This alignment keeps the load pin **314** affixed in the travel channel **302**.

[0139] When the neutral block is engaged **334** and the load pin **314** is affixed in the travel channel **302**, the passive exoskeleton **200** does not bear any of the load and therefore does not benefit a user. This is because the load pin **314** remains in the travel channel **302**, the travel channel **302** remains aligned with the sliding rod **205**, and the load pin **314** does not enter the load channel **304**. Additionally, when the neutral block **334** is engaged, the rocker **300** is not free to rotate and therefore does not interfere with the stride of the user during the user's gait.

[0140] (4) The Present Invention in Motion

[0141] The passive exoskeleton of the present invention is well-suited for both forward and reverse motion. Although the rocker and rocker stops are sufficient for forward motion, the rocker and rocker stops alone do not allow for sufficient reverse motion. Accordingly, the present invention includes the bias block and pressure mechanism which aids in rotating the rocker during reverse motion. To improve clarity, this section is divided into two subsections, forward motion and reverse motion. FIGS. 4 through 30B illustrate forward motion, showing the function of the rocker and rocker stops. FIGS. 31A through 43B illustrate reverse motion, showing the function of the rocker, the bias block, and the pressure mechanism, as taken from a right hip view. Although the bias block is also functional during forward motion, it is illustrated herein to emphasize its applicability to reverse motion. As can be appreciated by one in the art, the described motions of the bias block (i.e., while in backward motion), can be reversed to illustrate the bias block in a forward motion.

[0142] (i) Forward Motion

[0143] As shown in FIG. 4, during heel-strike **106** (initial contact), the load pin **314** is in the load channel **304**. As weight is transferred to a user's right leg **400**, the weight of

a load is transferred through the body member and rocker **300**, via the load pin **314**, to the load rod **214** and the ground **206**. The rocker **300** continues to bear weight of the load during the stance phase as the load pin **314** remains in the load channel **304**.

[0144] FIGS. 5, 6, and 7 illustrate the loading response, mid-stance and terminal stance positions respectively. As shown in FIGS. 5, 6, and 7, during these positions the weight of the load continues to be borne by the load pin **314**, which transfers the weight from the rocker **300** to the load rod **214**.

[0145] As shown in FIG. 8, the weight of the load continues to be borne by the load pin **314** until the pre-swing phase, just before toe-off. At this point, the top component **328** of the rocker **300** reaches the front rocker stop **320**, which prevents further rotation of the rocker **300**. Before completing the stance phase, the load pin **314** continues to move up and to the left since the right knee **118** is bending. However, once the rocker **300** can no longer rotate, the load pin **314** is forced up into the travel channel **302**.

[0146] As shown in FIG. 9, during the initial swing and as the knee **118** bends, the distance between the ankle **116** and hip **114** joint decreases. The load pin **314** then travels along the travel channel **302** and substantially no weight is transferred from the rocker **300** to the load rod **214**.

[0147] The majority of variation in the hip-to-ankle distance **900** occurs during the swing phase. This is not a problem because the load pin **314** is in the travel channel **302** during this portion of the stride and the two rods (i.e., alignment rod **212** and load rod **214**) can slide freely relative to one another. As long as the stance and swing phases can be de-coupled using the rocker **300**, it is possible to use the rocker's **300** geometry in conjunction with a variety of springs and dashpots to smooth the motion. A spring placed in the load channel **304**, for example, would help smooth the motion of the load pin **314** during the stance phase. This would also prevent the load pin **314** from reaching the base of the load channel **304** and would therefore allow a smaller angle **312** between the load channel **304** and the travel channel **302**. This angle **312** could compensate for some variation in the hip-to-ankle distance **900** during the stance phase.

[0148] FIGS. 10 and 11 illustrate the mid swing and terminal swing positions respectively. As shown in FIGS. 10 and 11, as the user continues to walk and the leg **400** swings forward **1000**, the rocker **300** rotates in a counter-clockwise direction **1002**, with the load pin **314** continuing to travel along the travel channel **302**. While traveling in the travel channel **302**, the load pin **314** carries no load until the point where the right leg **400** is about to touch the ground again.

[0149] As shown in FIG. 12, before the end of the swing phase, the top component **328** hits the rear rocker stop **322**. Any further motion of the leg forward **1000** causes the load pin **314** to move into and along the load channel **304**, allowing the rocker **300** to take up the weight of the load after heel-strike **106**.

[0150] FIGS. 13A through 20B are perspective view illustrations of a passive exoskeleton **200**, both attached proximate a user (i.e., FIGS. 13A, 14A, 15A, 16A, 17A, 18A, 19A, and 20A) and without a user (i.e., FIGS. 13B, 14B, 15B, 16B, 17B, 18B, 19B, and 20B) as one side of the

exoskeleton **200** travels through a stance phase **102** and thereafter a swing phase **104**.

[0151] FIGS. 21A through 25B are side view illustrations of a passive exoskeleton **200**, both attached proximate a user (i.e., FIGS. 21A, 22A, 23A, 24A, and 25A) and without a user (i.e., FIGS. 21B, 22B, 23B, 24B, and 25B) as one side of the exoskeleton **200** travels through a stance phase **102**.

[0152] FIGS. 26A through 30B are front view illustrations of a passive exoskeleton **200**, both attached proximate a user (i.e., FIGS. 26A, 27A, 28A, 29A, and 30A) and without a user (i.e., FIGS. 26B, 27B, 28B, 29B, and 30B) as one side of the exoskeleton **200** travels through a stance phase **102**.

[0153] (ii) Reverse Motion

[0154] FIGS. 31A through 43B are side and top view illustrations of the rocker **300** and bias block **330** motion while a user is walking backwards **3104** (i.e., reverse motion). As shown in FIGS. 31A through 43B, the bias block **330** is added to divide the region between the two rocker stop **320/322** into five zones. The two rocker stops **320/322** represent two zones, allowing for give/compression. A quasi-equilibrium point **3100** represents a zone of division between the two divided zones **3102**. The two divided zones **3102** represent the area between the rocker stops **320/322** and the quasi-equilibrium point **3100**. The bias block **330** is curved, and aligned radially with the main pin (i.e., hip pin) so that the quasi-equilibrium point **3100** is aligned such that when loaded, the user's posture at rest when both feet are close together (i.e., standing) positions the rocker **300** and the bias block **330** in the quasi-equilibrium position **3100**.

[0155] Also, the bias block **330** functions in the two divided zones **3102** between the rocker stops **320/322**. A user wearing the exoskeleton can walk backwards **3104** when the bias block **330** is engaged, provided the user takes a smaller stride backwards **3104** than the rocker stops **320/322** are set for forward **3106** motion.

[0156] Also, as noted in FIGS. 31A through 43B, the spring force of the pressure mechanism **332** is represented by an arrow **3108**. Although not to scale, the size of the arrow **3108** is proportional to the amount of force on the bias block **330**.

[0157] FIGS. 31A and 31 are side and top view illustrations of the rocker **300** and bias block **330** in a default quasi-equilibrium position. As shown, the load pin **314** is in the travel channel **302**. The quasi-equilibrium position generally occurs during the recovery phase, when the foot is off of the ground. FIG. 31A is a side view of the rocker **300**, while FIG. 31B is a top view of the rocker **300** and bias block **330**.

[0158] FIGS. 32A and 32B are side and top view illustrations of the rocker **300** and the bias block **330** as a user begins a backward step during the recovery phase (i.e., with the foot off of the ground). As shown, the load pin **314** is still in the travel channel **302** as the bias block **330** begins exerting pressure against the top component **328** of the rocker **300**, thereby forcing the top component **328** toward the front rocker stop **320**. FIG. 32A is a side view of the rocker **300**, while FIG. 32B is a top view of the rocker **300** and bias block **330**.

[0159] FIGS. 33A and 33B are side and top view illustrations of the rocker 300 and the bias block 330 during a backward step extension of the recovery phase (i.e., with the foot still off of the ground). As shown, the load pin 314 is still in the travel channel 302 as the bias block 330 continues exerting pressure against the top component 328 of the rocker 330, thereby forcing the top component 328 toward the front rocker stop 320. FIG. 33A is a side view of the rocker 300, while FIG. 33B is a top view of the rocker 300 and bias block 330.

[0160] FIGS. 34A and 34B are side and top view illustrations of the rocker 300 and the bias block 330 during a backward step as the foot has just touched the ground (i.e., transition to stance phase). As shown, the load pin 314 is at the intersection of the travel channel 302 and the load channel 304, with the bias block 330 continuing to exert pressure against the top component 328 of the rocker 330, thereby forcing the top component 328 toward the front rocker stop 320 and the load pin 314 into the load channel 304. FIG. 34A is a side view of the rocker 300, while FIG. 34B is a top view of the rocker 300 and bias block 330.

[0161] FIGS. 35A and 35B are side and top view illustrations of the rocker 300 and the bias block 330 during a stance phase of the backward step with the foot on the ground. As shown, the load pin 314 is in the load channel 304. FIG. 35A is a side view of the rocker 300, while FIG. 35B is a top view of the rocker 300 and bias block 330.

[0162] FIGS. 36A and 36B are side and top view illustrations of the rocker 300 and the bias block 330 during a furtherance of the backward step stance phase with the foot still on the ground. As shown, the load pin 314 is still in the load channel 304. FIG. 36A is a side view of the rocker 300, while FIG. 36B is a top view of the rocker 300 and bias block 330.

[0163] FIGS. 37A and 37B are side and top view illustrations of the rocker 300 and the bias block 330 during a furtherance of the backward step stance phase with the foot still on the ground. As shown, the load pin 314 is still in the load channel 304. FIG. 37A is a side view of the rocker 300, while FIG. 37B is a top view of the rocker 300 and bias block 330.

[0164] FIGS. 38A and 38B are side and top view illustrations of the rocker 300 and the bias block 330 during a furtherance of the backward step stance phase with the foot still on the ground. As shown, the load pin 314 is still in the load channel 304. FIG. 38A is a side view of the rocker 300, while FIG. 38B is a top view of the rocker 300 and bias block 330.

[0165] FIGS. 39A and 39B are side and top view illustrations of the rocker 300 and the bias block 330 during a furtherance of the backward step stance phase with the foot still on the ground. As shown, the load pin 314 is still in the load channel 304, while the top component 328 of the rocker 300 passes the quasi-equilibrium point. FIG. 39A is a side view of the rocker 300, while FIG. 39B is a top view of the rocker 300 and bias block 330.

[0166] FIGS. 40A and 40B are side and top view illustrations of the rocker 300 and the bias block 330 during a backward step as the foot still touches the ground but is no longer loaded (i.e., transition to swing phase). As shown, the load pin 314 is at the intersection of the travel channel 302

and the load channel 304, with the bias block 330 exerting pressure against the top component 328 of the rocker 330, thereby forcing the top component 328 toward the rear rocker stop 322 and the load pin 314 toward the intersection of the load channel 304 and travel channel 302. FIG. 40A is a side view of the rocker 300, while FIG. 40B is a top view of the rocker 300 and bias block 330.

[0167] FIGS. 41A and 41B are side and top view illustrations of the rocker 300 and the bias block 330 during a furtherance of the backward step swing phase with the foot no longer touching the ground (i.e., in the air). As shown, the load pin 314 has shifted into the travel channel 302, while the top component 328 of the rocker 300 begins returning toward the quasi-equilibrium point. FIG. 41A is a side view of the rocker 300, while FIG. 41B is a top view of the rocker 300 and bias block 330.

[0168] FIGS. 42A and 42B are side and top view illustrations of the rocker 300 and the bias block 330 during a furtherance of the backward step swing phase with the foot still in the air. As shown, the load pin 314 is in the travel channel 302, while the top component 328 of the rocker 300 continues returning mid-stance the quasi-equilibrium point. FIG. 42A is a side view of the rocker 300, while FIG. 42B is a top view of the rocker 300 and bias block 330.

[0169] FIGS. 43A and 43B are side and top view illustrations of the rocker 300 and bias block 330 after having returned to the default quasi-equilibrium position during the recovery phase, with the foot still off of the ground. As shown, the load pin 314 is still in the travel channel 302. FIG. 43A is a side view of the rocker 300, while FIG. 43B is a top view of the rocker 300 and bias block 330.

[0170] As mentioned previously, motion of the bias block was illustrated herein during backward motion. However, and as can be appreciated by one in the art, the motion of the bias block is not limited to backward motion and operates in a similar fashion while a user is traveling forward.

What is claimed is:

1. A passive exoskeleton for aiding a user in bearing a load, the passive exoskeleton comprising:

a rocker for attaching with a body member, the rocker having a travel channel and a load channel incorporated therein, the travel channel being an elongated channel oriented directionally from proximate the body member to a ground surface, and the load channel formed as an elongated channel and positioned such that an angle between the load channel and the travel channel is less than ninety degrees, both the load channel and the travel channel formed to accommodate a load pin, the rocker also including a top component;

a bias block for attaching with the body member and for engaging with the top component of the rocker, both the bias block and the top component of the rocker are formed in such a manner that as a user walks and shifts between a swing phase and a stance phase, the top component of the rocker passes a point of equilibrium where the bias block turns the rocker to aid the load pin in transferring between the load channel and travel channel, thereby shifting the load from the rocker onto the load pin and ultimately to a ground surface, causing the passive exoskeleton to support at least a portion of the load.

2. A passive exoskeleton as set forth in claim 1, further comprising a body member for attaching proximate a portion of a user's body, with the rocker pivotally attached with the body member.

3. A passive exoskeleton as set forth in claim 2, further comprising a sliding rod attached with the body member.

4. A passive exoskeleton as set forth in claim 3, further comprising a load pin attached with the sliding rod and operably attached with the rocker through both the travel channel and the load channel, formed such that as a user walks and shifts from a swing phase to a stance phase, the load is transferred from the body member to the rocker, the shift causing the load pin to travel between the travel channel and the load channel, with weight from the load being transferred from the load channel to the load pin and the sliding rod, and thereafter through the sliding rod and ultimately a ground surface, causing the passive exoskeleton to support at least a portion of the load.

5. A passive exoskeleton as set forth in claim 4, further comprising a ground surface engage-able foot analog attached with the sliding rod, whereby weight from the load is transferred from the sliding rod to the foot analog and ultimately a ground surface, causing the passive exoskeleton to support at least a portion of the load.

6. A passive exoskeleton as set forth in claim 5, further comprising a pressure mechanism attached with the bias block for forcing the bias block against the top component of the rocker, thereby aiding the bias block in turning the rocker after the top component of the rocker passes the point of equilibrium.

7. A passive exoskeleton as set forth in claim 6, wherein the pressure mechanism is selected from a group consisting of a spring and hydraulics.

8. A passive exoskeleton as set forth in claim 7, further comprising a neutral block attached with the passive exoskeleton, the neutral block formed in such a manner that it is engage-able with the rocker to prevent the rocker from moving, such that when engaged with the rocker and when the load pin is in the travel channel, the load pin is maintained in the travel channel and is unable to transfer to the load channel, thereby causing the user to bear the full weight of the load.

9. A passive exoskeleton as set forth in claim 8, wherein the sliding rod further comprises:

an alignment rod, where the alignment rod has a top portion, a bottom portion, and a length with an axis therethrough, and where the top portion of the alignment rod is pivotally attached with the body member;

a load rod in a fixed parallel alignment with the axis of the alignment rod, where the load rod has a top part and a bottom part, and where the load rod is connected with the alignment rod such that a length of the sliding rod is adjustable by sliding the top part of the load rod between the bottom portion and top portion of the alignment rod; and

wherein the load pin is attached with the load rod, whereby as a user walks and shifts from a swing phase to a stance phase, the load is transferred from the body member to the rocker, the shift causing the load pin to travel between the travel channel and the load channel, thereby shifting the load from the rocker onto the load pin and thereafter through the load rod and the foot analog to the ground surface.

10. A passive exoskeleton as set forth in claim 9, wherein the body member is rigid, allowing the passive exoskeleton to transfer weight from the body member and through the passive exoskeleton to the ground surface.

11. A passive exoskeleton as set forth in claim 10, wherein the load rod further comprises an ankle joint attached with the bottom part of the load rod, where the ankle joint pivotally connects the load rod with the foot analog.

12. A passive exoskeleton as set forth in claim 11, wherein the rocker has a first side and a second side, and both the travel channel and the load channel are formed through the rocker from the first side to the second side.

13. A passive exoskeleton as set forth in claim 12, further comprising a front rocker stop and a rear rocker stop, the front rocker stop and the rear rocker stop being attached with the body member, and wherein the rocker further comprises a top component for engaging with both the front and rear rocker stops, formed such that when a user is walking, the rocker travels from a forward position to a rear position, and when the rocker is in a forward position, the top component engages with the rear rocker stop, and when the rocker is in a rear position, the top component engages with the front rocker stop.

14. A passive exoskeleton as set forth in claim 13, further comprising a foot connector attached with the foot analog, whereby a user may utilize the foot connector to securely attach the foot analog with the user's foot or shoe, thereby allowing the foot analog to maintain a position proximate the user's foot.

15. A passive exoskeleton as set forth in claim 14, further comprising a body attachment attached with the body member, the body attachment being selected from a group consisting of a flexible harness, a belt, and suspenders, where the body attachment is for attaching with a torso portion of a user, allowing the user to operate the exoskeleton and maintain the exoskeleton in a position proximate the user.

16. A passive exoskeleton as set forth in claim 15, further comprising a load frame attached with the body member, whereby a user may attach a load with the load frame and thereby transfer weight from the load, through the exoskeleton and to the ground surface.

17. A passive exoskeleton as set forth in claim 5, further comprising a foot connector attached with the foot analog, whereby a user may utilize the foot connector to securely attach the foot analog with the user's foot or shoe, thereby allowing the foot analog to maintain a position proximate the user's foot.

18. A passive exoskeleton as set forth in claim 3, wherein the sliding rod further comprises:

an alignment rod, where the alignment rod has a top portion, a bottom portion, and a length with an axis therethrough, and where the top portion of the alignment rod is pivotally attached with the body member;

a load rod in a fixed parallel alignment with the axis of the alignment rod, where the load rod has a top part and a bottom part, and where the load rod is connected with the alignment rod such that a length of the sliding rod is adjustable by sliding the top part of the load rod between the bottom portion and top portion of the alignment rod; and

wherein the load pin is attached with the load rod, whereby as a user walks and shifts from a swing phase

to a stance phase, the load is transferred from the body member to the rocker, the shift causing the load pin to travel between the travel channel and the load channel, thereby shifting the load from the rocker onto the load pin and thereafter through the load rod and the foot analog to the ground surface.

19. A passive exoskeleton as set forth in claim 18, wherein the load rod further comprises an ankle joint attached with the bottom part of the load rod, where the ankle joint is formed to pivotally connect the load rod with a foot analog.

20. A passive exoskeleton as set forth in claim 2, further comprising a front rocker stop and a rear rocker stop, the front rocker stop and the rear rocker stop being attached with the body member, and wherein the rocker further comprises a top component for engaging with both the front and rear rocker stops, formed such that when a user is walking, the rocker travels from a forward position to a rear position, and when the rocker is in a forward position, the top component engages with the rear rocker stop, and when the rocker is in a rear position, the top component engages with the front rocker stop.

21. A passive exoskeleton as set forth in claim 2, further comprising a body attachment attached with the body member, the body attachment being selected from a group consisting of a flexible harness, a belt, and suspenders, where the body attachment is for attaching with a torso portion of a user, allowing the user to operate the exoskeleton and maintain the exoskeleton in a position proximate the user.

22. A passive exoskeleton as set forth in claim 2, wherein the body member is rigid, allowing the passive exoskeleton to transfer weight from the body member and through the passive exoskeleton to the ground surface.

23. A passive exoskeleton as set forth in claim 1, further comprising a pressure mechanism attached with the bias block for forcing the bias block against the top component of the rocker, thereby aiding the bias block in turning the rocker after the top component of the rocker passes the point of equilibrium.

24. A passive exoskeleton as set forth in claim 23, wherein the pressure mechanism is selected from a group consisting of a spring and hydraulics.

25. A passive exoskeleton as set forth in claim 1, further comprising a neutral block attached with the passive exoskeleton, the neutral block formed in such a manner that it is engage-able with the rocker to prevent the rocker from moving, such that when engaged with the rocker and when the load pin is in the travel channel, the load pin is maintained in the travel channel and is unable to transfer to the load channel, thereby causing the user to bear the full weight of the load.

26. A passive exoskeleton as set forth in claim 1, wherein the rocker has a first side and a second side, and both the travel channel and the load channel are formed through the rocker from the first side to the second side.

27. A passive exoskeleton as set forth in claim 1, further comprising a load frame attached with the body member, whereby a user may attach a load with the load frame and thereby transfer weight from the load, through the exoskeleton and to the ground surface.

28. A kit for building a passive exoskeleton, the kit comprising:

a rocker for attaching with a body member, the rocker having a travel channel and a load channel incorporated

therein, the travel channel being an elongated channel oriented directionally from proximate the body member to a ground surface, and the load channel formed as an elongated channel and positioned such that an angle between the load channel and the travel channel is less than ninety degrees, both the load channel and the travel channel formed to accommodate a load pin, the rocker also including a top component;

a bias block for attaching with the body member and for engaging with the top component of the rocker, both the bias block and the top component of the rocker are formed in such a manner that as a user walks and shifts between a swing phase and a stance phase, the top component of the rocker passes a point of equilibrium where the bias block turns the rocker to aid the load pin in transferring between the load channel and travel channel, thereby shifting the load from the rocker onto the load pin and ultimately to a ground surface, causing the passive exoskeleton to support at least a portion of the load.

29. A kit for building a passive exoskeleton as set forth in claim 28, further comprising a body member for attaching proximate a portion of a user's body, with the rocker pivotally attached with the body member.

30. A kit for building a passive exoskeleton as set forth in claim 29, further comprising a sliding rod attached with the body member.

31. A kit for building a passive exoskeleton as set forth in claim 30, further comprising a load pin attached with the sliding rod and operably attached with the rocker through both the travel channel and the load channel, formed such that as a user walks and shifts from a swing phase to a stance phase, the load is transferred from the body member to the rocker, the shift causing the load pin to travel between the travel channel and the load channel, with weight from the load being transferred from the load channel to the load pin and the sliding rod, and thereafter through the sliding rod and ultimately a ground surface, causing the passive exoskeleton to support at least a portion of the load.

32. A kit for building a passive exoskeleton as set forth in claim 31, further comprising a ground surface engage-able foot analog attached with the sliding rod, whereby weight from the load is transferred from the sliding rod to the foot analog and ultimately a ground surface, causing the passive exoskeleton to support at least a portion of the load.

33. A kit for building a passive exoskeleton as set forth in claim 32, further comprising a foot connector attached with the foot analog, whereby a user may utilize the foot connector to securely attach the foot analog with the user's foot or shoe, thereby allowing the foot analog to maintain a position proximate the user's foot.

34. A kit for building a passive exoskeleton as set forth in claim 30, wherein the sliding rod further comprises:

an alignment rod, where the alignment rod has a top portion, a bottom portion, and a length with an axis therethrough, and where the top portion of the alignment rod is pivotally attached with the body member;

a load rod in a fixed parallel alignment with the axis of the alignment rod, where the load rod has a top part and a bottom part, and where the load rod is connected with the alignment rod such that a length of the sliding rod

is adjustable by sliding the top part of the load rod between the bottom portion and top portion of the alignment rod; and

wherein the load pin is attached with the load rod, whereby as a user walks and shifts from a swing phase to a stance phase, the load is transferred from the body member to the rocker, the shift causing the load pin to travel between the travel channel and the load channel, thereby shifting the load from the rocker onto the load pin and thereafter through the load rod and the foot analog to the ground surface.

35. A kit for building a passive exoskeleton as set forth in claim 34, wherein the load rod further comprises an ankle joint attached with the bottom part of the load rod, where the ankle joint is formed to pivotally connect the load rod with a foot analog.

36. A kit for building a passive exoskeleton as set forth in claim 29, further comprising a front rocker stop and a rear rocker stop, the front rocker stop and the rear rocker stop being attached with the body member, and wherein the rocker further comprises a top component for engaging with both the front and rear rocker stops, formed such that when a user is walking, the rocker travels from a forward position to a rear position, and when the rocker is in a forward position, the top component engages with the rear rocker stop, and when the rocker is in a rear position, the top component engages with the front rocker stop.

37. A kit for building a passive exoskeleton as set forth in claim 29, further comprising a body attachment attached with the body member, the body attachment being selected from a group consisting of a flexible harness, a belt, and suspenders, where the body attachment is for attaching with a torso portion of a user, allowing the user to operate the exoskeleton and maintain the exoskeleton in a position proximate the user.

38. A kit for building a passive exoskeleton as set forth in claim 29, wherein the body member is rigid, allowing the passive exoskeleton to transfer weight from the body member and through the passive exoskeleton to the ground surface.

39. A kit for building a passive exoskeleton as set forth in claim 28, further comprising a pressure mechanism attached with the bias block for forcing the bias block against the top component of the rocker, thereby aiding the bias block in turning the rocker after the top component of the rocker passes the point of equilibrium.

40. A kit for building a passive exoskeleton as set forth in claim 39, wherein the pressure mechanism is selected from a group consisting of a spring and hydraulics.

41. A kit for building a passive exoskeleton as set forth in claim 28, further comprising a neutral block attached with the passive exoskeleton, the neutral block formed in such a manner that it is engage-able with the rocker to prevent the rocker from moving, such that when engaged with the rocker and when the load pin is in the travel channel, the load pin is maintained in the travel channel and is unable to transfer to the load channel, thereby causing the user to bear the full weight of the load.

42. A kit for building a passive exoskeleton as set forth in claim 28, wherein the rocker has a first side and a second side, and both the travel channel and the load channel are formed through the rocker from the first side to the second side.

43. A kit for building a passive exoskeleton as set forth in claim 28, further comprising a load frame attached with the body member, whereby a user may attach a load with the load frame and thereby transfer weight from the load, through the exoskeleton and to the ground surface.

44. A method for forming a passive exoskeleton, the method comprising acts of:

forming a body member for attaching proximate a portion of a user's body;

attaching a sliding rod with the body member;

attaching a ground surface engage-able foot analog with the sliding rod;

pivotally attaching a rocker with the body member, the rocker having a travel channel and a load channel incorporated therein, the travel channel being an elongated channel oriented directionally from proximate the body member to the ground surface, and the load channel formed as an elongated channel and positioned such that an angle between the load channel and the travel channel is less than ninety degrees, the rocker also including a top component;

attaching a load pin with the sliding rod and operably attaching the load pin with the rocker through both the travel channel and the load channel, the load pin formed such that as a user walks and shifts from a swing phase to a stance phase, the load is transferred from the body member to the rocker with the shift causing the load pin to travel between the travel channel and the load channel;

attaching a bias block with the body member for engaging with the top component of the rocker, both the bias block and the top component of the rocker are formed in such a manner that as a user walks and shifts between the swing phase and stance phase, the top component of the rocker passes a point of equilibrium where the bias block turns the rocker to aid the load pin in transferring between the load channel and travel channel, thereby shifting the load from the rocker onto the sliding rod and thereafter through the sliding rod to the foot analog and ultimately a ground surface, causing the passive exoskeleton to support at least a portion of the load.

45. A method for forming a passive exoskeleton as set forth in claim 55, further comprising an act of attaching a pressure mechanism with the bias block for forcing the bias block against the top component of the rocker, thereby aiding the bias block in turning the rocker after the top component of the rocker passes the point of equilibrium.

46. A method for supporting a load, the method comprising an act of:

attaching a passive exoskeleton with a user's body, the passive exoskeleton comprising:

a body member for attaching proximate a portion of a user's body;

a sliding rod attached with the body member;

a ground surface engage-able foot analog attached with the sliding rod;

a rocker pivotally attached with the body member, the rocker having a travel channel and a load channel incorporated therein, the travel channel being an

elongated channel oriented directionally from proximate the body member to the ground surface, and the load channel formed as an elongated channel and positioned such that an angle between the load channel and the travel channel is less than ninety degrees, the rocker also including a top component;

- a load pin attached with the sliding rod and operably attached with the rocker through both the travel channel and the load channel, formed such that as a user walks and shifts from a swing phase to a stance phase, the load is transferred from the body member to the rocker, the shift causing the load pin to travel between the travel channel and the load channel;

a bias block attached with the body member for engaging with the top component of the rocker, both the bias block and the top component of the rocker are formed in such a manner that as a user walks and shifts between the swing phase and stance phase, the top component of the rocker passes a point of equilibrium where the bias block turns the rocker to aid the load pin in transferring between the load channel and travel channel, thereby shifting the load from the rocker onto the sliding rod and thereafter through the sliding rod to the foot analog and ultimately a ground surface, causing the passive exoskeleton to support at least a portion of the load.

* * * * *