



US 20080195005A1

(19) **United States**

(12) **Patent Application Publication**
Horst et al.

(10) **Pub. No.: US 2008/0195005 A1**

(43) **Pub. Date: Aug. 14, 2008**

(54) **METHODS AND DEVICES FOR DEEP VEIN THROMBOSIS PREVENTION**

Publication Classification

(76) Inventors: **Robert W. Horst**, San Jose, CA (US); **Kern Bhugra**, San Jose, CA (US); **Thomas J. Fogarty**, (US)

(51) **Int. Cl.**
A61H 1/00 (2006.01)
A61F 5/00 (2006.01)
A63B 24/00 (2006.01)
A63B 26/00 (2006.01)

Correspondence Address:
PERKINS COIE LLP
P.O. BOX 2168
MENLO PARK, CA 94026

(52) **U.S. Cl.** **601/22; 482/7; 482/78; 602/23**

(21) Appl. No.: **11/932,799**
(22) Filed: **Oct. 31, 2007**

(57) **ABSTRACT**

Portable devices and methods for preventing deep vein thrombosis (DVT) by assuring that the ankle is flexed and extended sufficiently to promote blood flow in the lower leg are disclosed. The device includes an actuator with a free movement mode that allows a patient to move freely between activations or to initiate movement to delay a next automatic activation.

Related U.S. Application Data

(60) Provisional application No. 60/901,614, filed on Feb. 14, 2007.

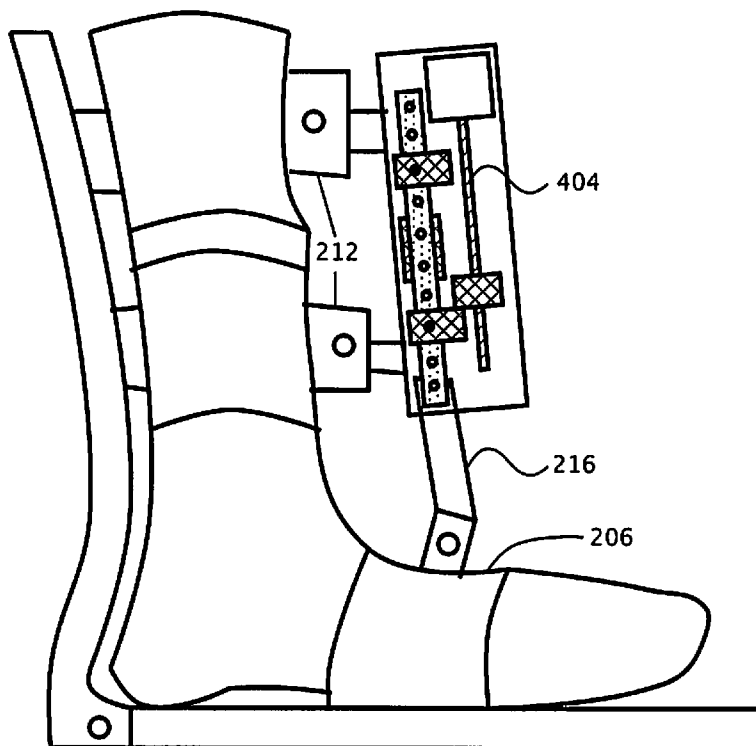

ACTUATOR AND ANKLE ATTACHMENT

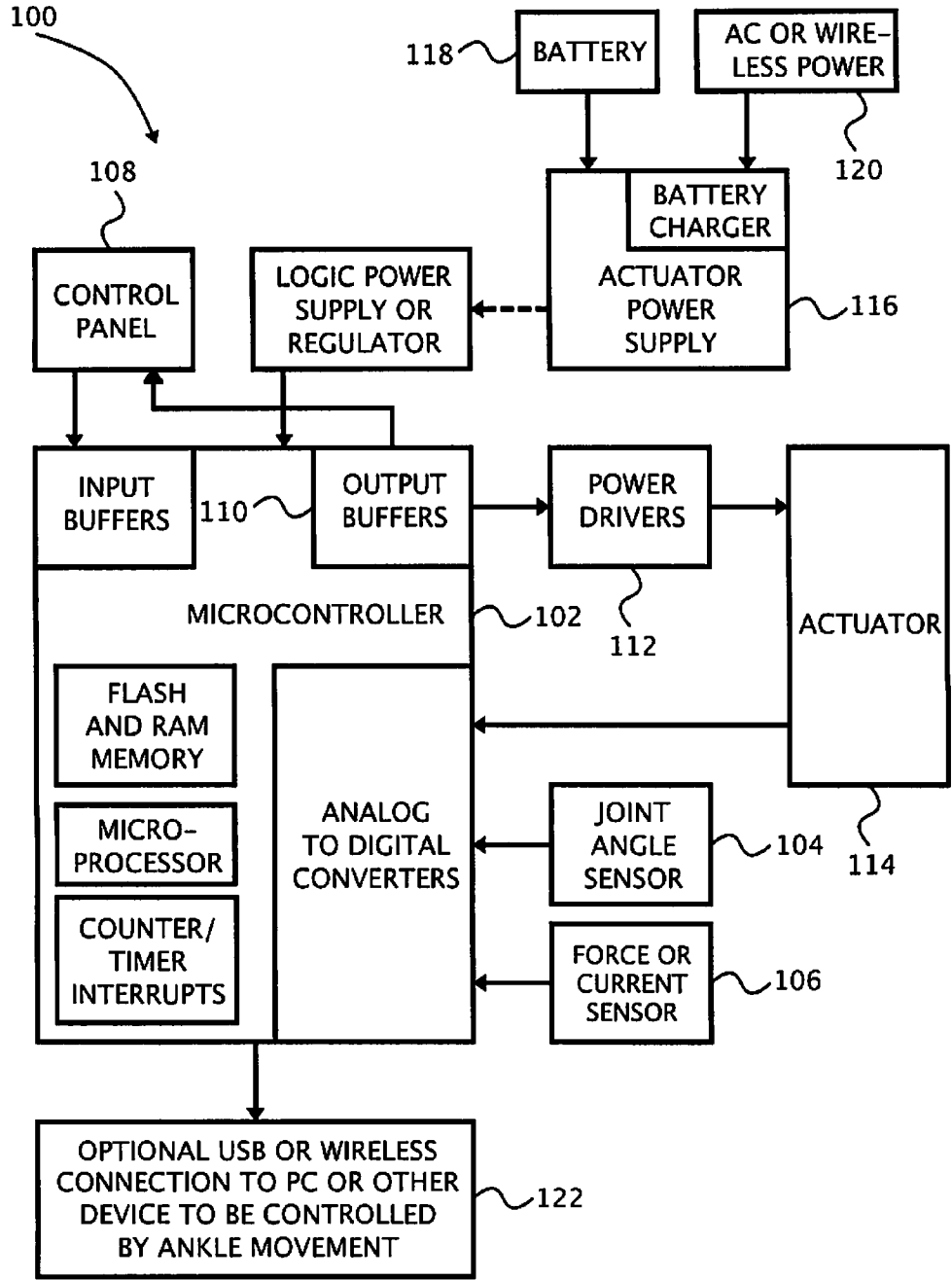
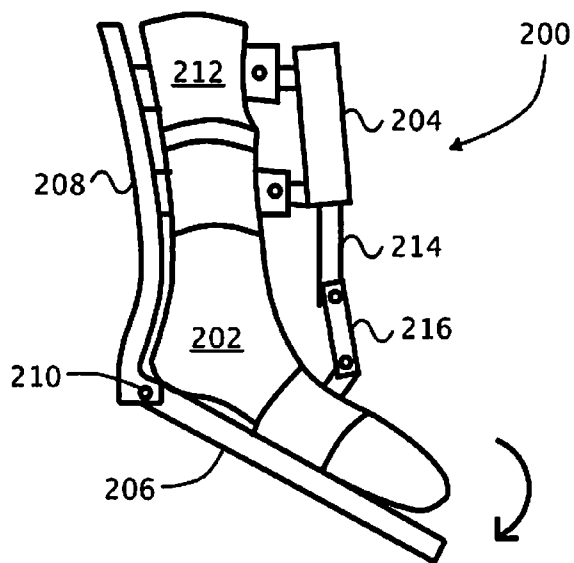
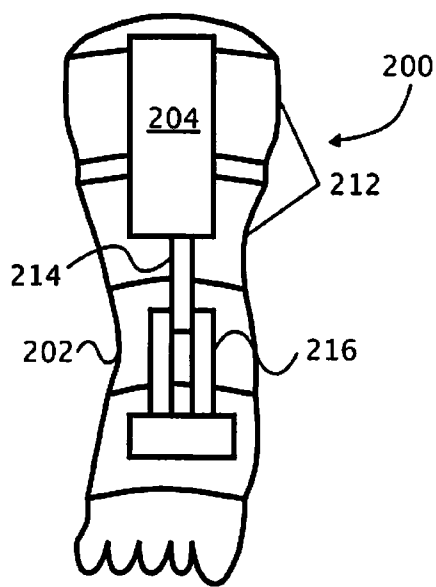
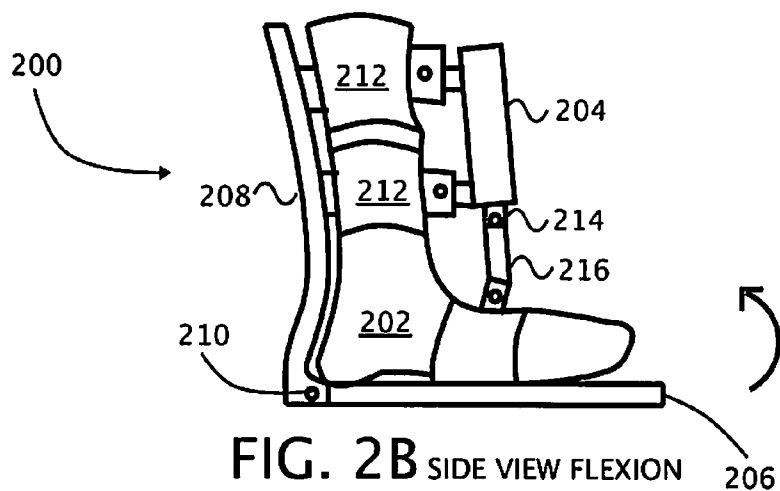

FIG. 1 BLOCK DIAGRAM



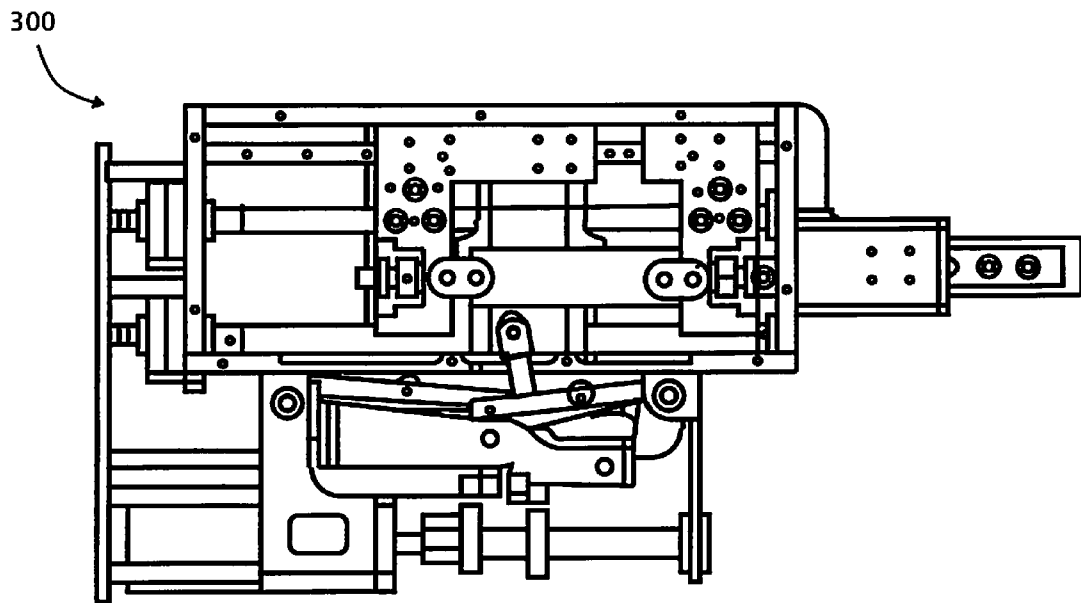

FIG. 3 Continuously Variable Actuator

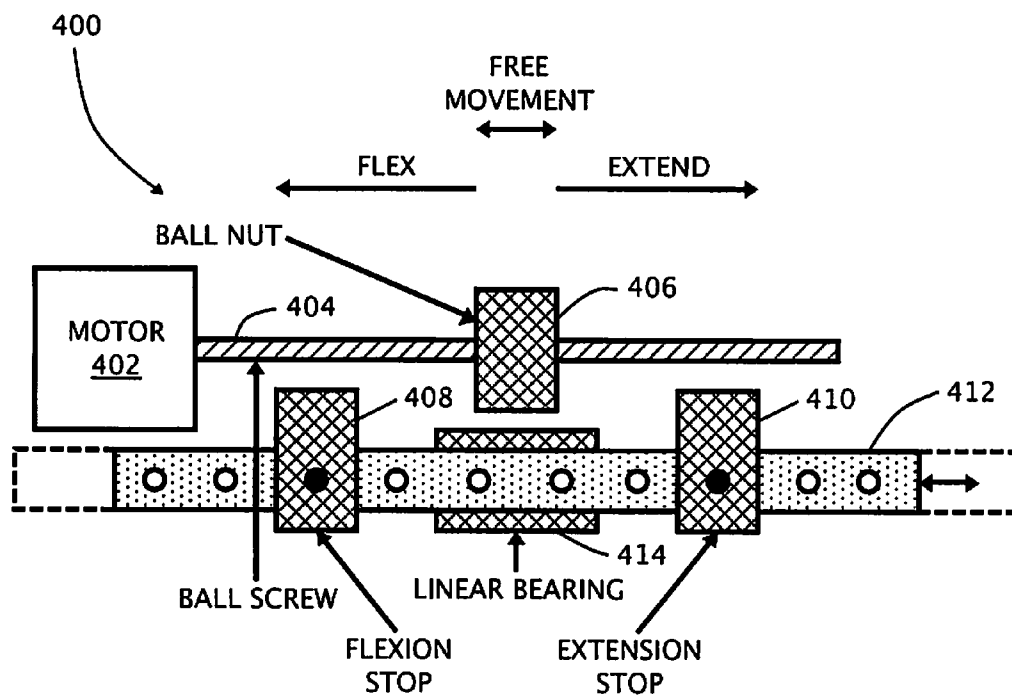

FIG. 4 SINGLE MOTOR ACTUATOR

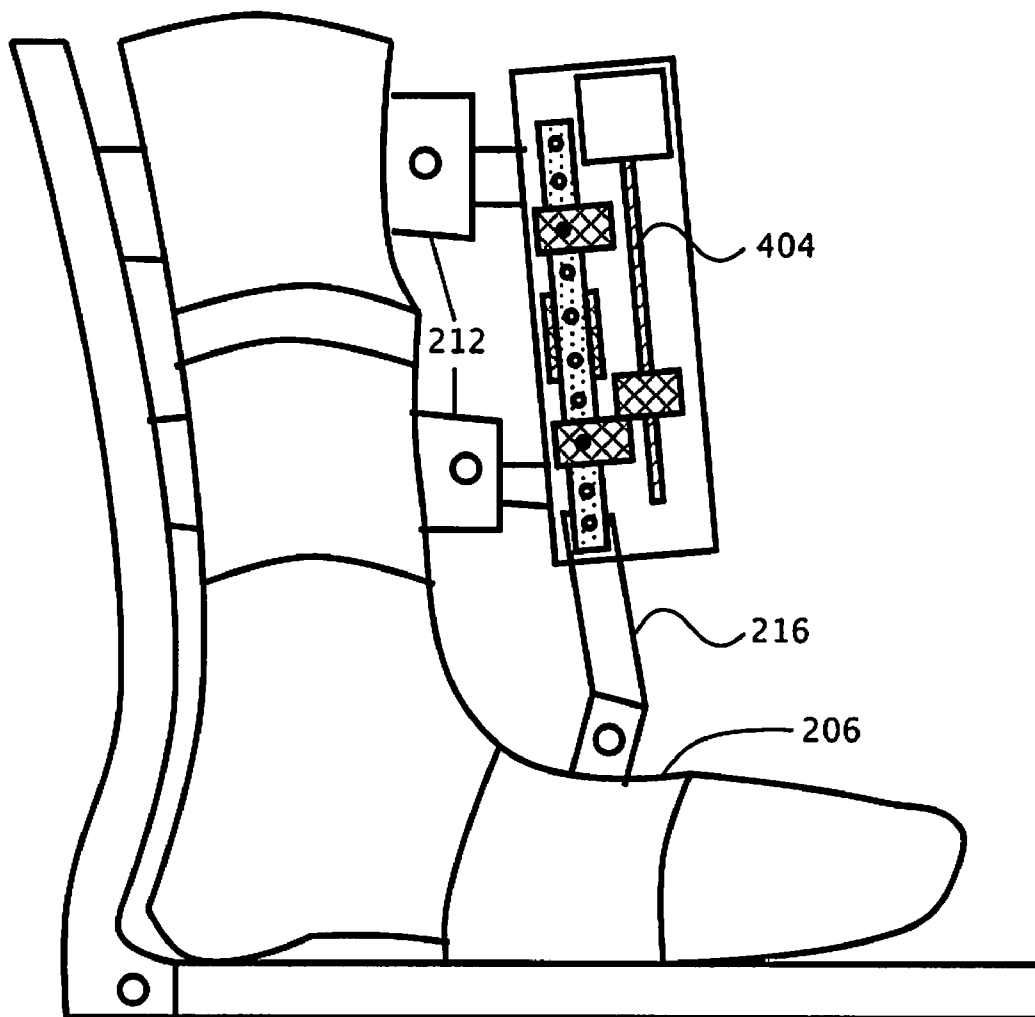

FIG. 5 ACTUATOR AND ANKLE ATTACHMENT

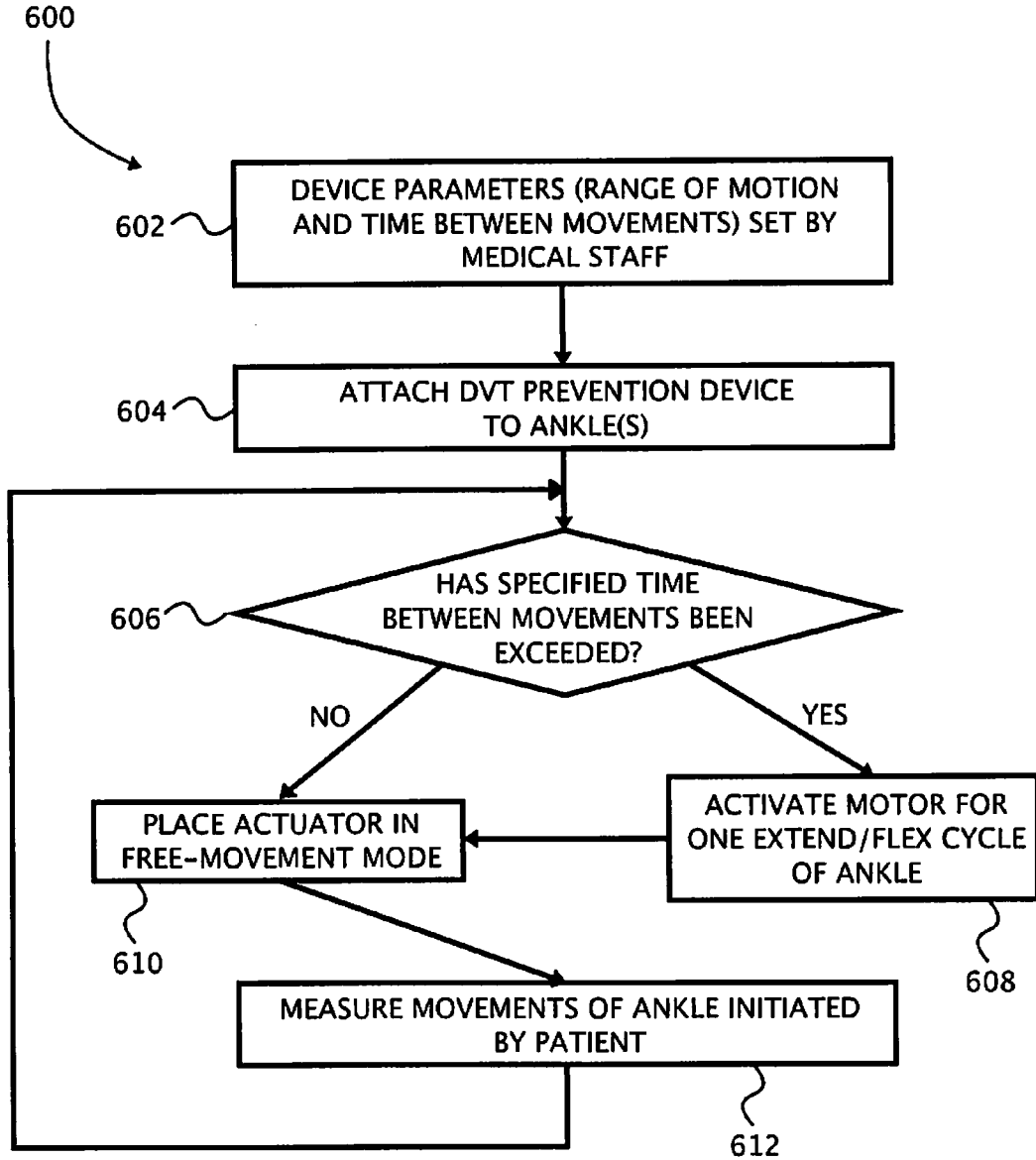

FIG. 6 FLOWCHART OF DVT PREVENTION ALGORITHM

METHODS AND DEVICES FOR DEEP VEIN THROMBOSIS PREVENTION

CLAIM OF PRIORITY

[0001] This application claims priority to U.S. Provisional Patent Application No. 60/901,614 entitled "Password Generator And Storage Device", which was filed on Feb. 14, 2007, the contents of which are expressly incorporated by reference herein.

BACKGROUND OF THE INVENTION

[0002] Deep Vein Thrombosis (DVT) is the formation of a thrombus (clot) in a deep vein in a leg. The clot can block blood flow in the leg, or the clot may travel to the lungs causing a potentially fatal pulmonary embolism. The incidence of DVT is particularly high after hip or knee surgery, but may occur whenever patients are immobilized over a period of time. DVT occurrence is known to be high after lower extremity paralysis due to stroke or injury and is also a risk factor in pregnancy, obesity, and other conditions.

[0003] Current techniques for avoiding DVT have drawbacks. For example, blood thinning drugs have side effects, elastic stockings and compression devices have limited effectiveness, while compression and exercise devices have limited patient compliance. Active or passive movement of the ankle, alone or in combination with other DVT avoidance techniques, can reduce the incidence of DVT; however there has been no device to assure adequate movement that is acceptable to hospital patients and staff.

SUMMARY OF THE INVENTION

[0004] The present invention teaches a variety of methods, techniques and devices for preventing deep vein thrombosis (DVT). According to one embodiment, a DVT prevention device is attached to a patient's ankle, or any portion of any limb, to deliver active or passive movement to promote blood flow in the lower extremities. According to certain aspects, the DVT prevention device includes a battery or AC-powered actuator, an embedded computer, a software control system, sensors, and a coupling to the ankle and the foot.

[0005] According to another embodiment, a DVT prevention device operates in one or more modes to supply 1) passive extension and flexion of the ankle, 2) active extension and flexion of the ankle, and 3) free movement of the ankle. Patient compliance may be enhanced by allowing the patient to determine the preferred mode of operation; the device assures adequate total movement over a period of time by supplying passive movement when necessary. For example, the patient may perform enough movements in free-movement mode to delay future activations of the device, or the patient may actively resist the movement to exercise the calf muscles and promote enhanced blood flow beyond that of passive movement.

[0006] According to yet another aspect of the present invention, the present invention may include an output connection to allow the patient's extension and flexion of the ankle to serve as a human interface device similar to a computer mouse. If coupled to a web browser or computer game, the device can serve the dual role of preventing DVT and helping the patient to pass time more quickly. Such a device

can also serve as the primary input device to those with arm or hand disabilities and may tend to avoid or mitigate carpal tunnel syndrome.

BRIEF DESCRIPTION OF THE DRAWINGS

[0007] FIG. 1 is a block diagram of electronics and an embedded computer that controls a deep vein THROMBOSIS (DVT) prevention device according to an embodiment of the present invention.

[0008] FIG. 2a shows a front view of a DVT prevention device attached to the leg of a patient according to an embodiment of the present invention.

[0009] FIG. 2b shows a side view of the DVT prevention device of FIG. 2a near the flexion limit.

[0010] FIG. 2c shows a side view of the DVT prevention device near the extension limit.

[0011] FIG. 3. shows a continuously variable actuator according to another aspect of the present invention that may be used to construct a DVT prevention device

[0012] FIG. 4. shows a single-motor actuator with a free movement mode according to another embodiment of the present invention.

[0013] FIG. 5. shows a single-motor actuator as attached to an ankle according to a further embodiment of the present invention.

[0014] FIG. 6. is a flowchart of a method for the prevention of DVT according to one aspect of the present invention.

DESCRIPTION OF THE PREFERRED EMBODIMENTS

[0015] FIG. 1 shows a block diagram of a deep vein THROMBOSIS (DVT) prevention device 100 according to an embodiment of the present invention. An embedded microcontroller 102 is programmed to accept input from one or more sensors such as joint angle sensor 104 and a force (e.g., current) sensor 106. The embedded microcontroller 102 may also be coupled to a control panel 108. The control panel 108 may be for use by a patient, a doctor, or other health care provider. The embedded microcontroller 102 is operable to produce outputs for power drivers 112 to control the motion of one or more actuators 114.

[0016] With further reference to FIG. 1, power is supplied to the DVT prevention device 100 through an actuator power supply 116. Power may come through a battery 118 or from an AC adapter 120. In one embodiment, the battery 118 is wirelessly recharged by inductive coupling to a pad conveniently placed, such as at the foot of a hospital bed. Such a wireless recharge device has been announced by Wildcharge at the 2007 Consumer Electronics show.

[0017] In certain embodiments, such as cases where the patient can supply significant force to exercise the ankle, the battery charging requirements may be reduced or eliminated by recharging the battery from energy captured from running the actuator 114 as backdriven motor generator. This may provide an extra incentive to the patient to exercise, especially if the amount of exercise is recorded and presented to the patient, the patient's family and the hospital staff.

[0018] The control panel 108 may be as simple as an on/off switch, or may include switches and displays to allow adjustments for the range of motion, minimum repetition frequency, movement statistics, battery charge, and the like.

[0019] One embodiment includes a USB or wireless connection 122 to allow the DVT prevention device 100, or a pair

of devices (e.g., one device each on the left and right ankles), to act as a human interface device (HID) that may be connected, for instance, to a PC. For example, the right ankle position may determine the left/right location of a computer cursor and the left ankle position may determine the up/down location of the cursor. When a patient uses the computer, for instance to surf the internet or play a game, the ankles must be flexed and extended, and in the process the blood flow to the leg is enhanced. The computer connection may significantly enhance patient compliance, which is a major problem with existing compression devices.

[0020] FIG. 2 shows three views of a DVT prevention device 200, according to another embodiment of the present invention, attached to an ankle 202. An actuator 204 is attached to upper and lower ankle attachment points such that activation of the actuator 204 may extend or flex the ankle 202. FIG. 2a shows a front view of the DVT prevention device 200, FIG. 2b shows a side view of the DVT prevention device 200 near a flexion limit, and FIG. 2c shows a side view of the DVT prevention device 200 near an extension limit. The limits may be programmatically or physically limited within the patient's range of motion. As will be appreciated, a typical extension limit (also known as Planar Flexion) is about 45 degrees from the standing position of the ankle, and a typical flexion limit (also known as Doral Flexion) is about -20 degrees from the standing position.

[0021] With further reference to FIG. 2, a rigid foot support structure 206 is placed under the foot and a rigid ankle support 208 structure is placed behind the calf. The two support structures 206 and 208 are connected to each other with a hinge 210. The actuator 204 is mounted to the upper rigid structure 208. Straps or padded supports 212 hold the ankle support structure 208 and actuator 204 to the lower leg. An output shaft 214 of the actuator 204 is connected to a linkage 216 attached to the foot support structure 206. One or more straps 212 hold the foot support structure 206 to the foot.

[0022] FIG. 3 shows a continuously variable actuator 300 suitable for use as an actuator according to certain embodiments of the present invention. One suitable example of the continuously variable actuator is described in more detail in the Horst et al.'s U.S. patent application Ser. No. 11/649,394, filed Jan. 3, 2007, the contents of which are incorporated herein by reference. The actuator 300 uses a flexible belt connected by belt supports, two motor-driven lead screws and a motor driven cam to provide variable drive ratio forces in either direction or to allow the output shaft to move in a free-movement mode.

[0023] FIG. 4 shows a single-motor actuator 400 suitable for use as an actuator according to another embodiment of the present invention. In the single-motor actuator 400, a motor 402, which may have an internal gear head, drives a lead screw 404 to move a nut 406 linearly. The lead screw 404 may be an acme screw, a ball screw with a ball nut for lower friction and higher motor efficiency, or any other suitable screw. The ball nut 406 is always between a flexion stop 408 and an extension stop 410 connected to an output shaft 412. When the ball nut 406 is in a center of travel, the output shaft 412 is free to move linearly in either direction without having movement impeded by interaction with the ball nut 406. This position provides free movement of the output shaft 412, and likewise free movement of the ankle or other relevant body part, even with no power applied to the actuator 400. When it is time to extend or flex the ankle, the ball screw 404 is turned to move the ball nut 406 to the left or the right where the ball

nut 406 eventually pushes against the flexion or extension stop. Further movement of the ball nut 406 in the same direction moves the flexion stop 408 or the extension stop 410, and hence moves the output shaft 412, thus causing the ankle to flex or extend, respectively. The output shaft 412 is supported by one or more linear bearings 414 allowing the output shaft 412 to move freely in one dimension while preventing substantial movement or twisting in other dimensions.

[0024] To further elaborate, lead screws include types of screws such as acme screws and ball screws. Ball screws have nuts with recirculating ball bearings allowing them to be backdriven more easily than acme screws. When using a ball screw, motion of the nut causes the lead screw and hence the motor to rotate. Therefore, when the ball nut is engaged by one of the stops, the patient may exercise the leg muscles by extending or flexing the foot to cause motion of the output shaft and hence cause motion of the motor. Exercise may be accomplished either by resisting the passive motions imparted by the actuator, or through a separate exercise mode where all motion is caused by the patient. In either case, software running in the embedded processor controls the amount of current delivered to/from the motor and therefore the amount of exercise resistance.

[0025] FIG. 5 shows the single motor actuator 400 of FIG. 4 attached to an ankle support 212 and coupled to a foot support 206 through a linkage 216. The ball screw 404 in the actuator 400 is shown in a position about to extend the ankle by pushing to the right. Near the extension and flexion limits, some compliance may be built in to provide more comfort to the patient and to assure that there is no possibility of injuring the patient. This may be accomplished by springs in the actuator 400 or springs in the linkage 216, or both (not shown), that expand or compress before damaging forces are applied.

[0026] To further elaborate, a free-movement mode of the actuator 400 allows the patient to move the ankle with little resistance. The free movement mode obviates the need to remove the DVT prevention device when walking (for instance, to the restroom); this improves patient compliance because there is no need for the patient or hospital staff to remove and reattach the DVT protection device frequently.

[0027] FIG. 6 is a flowchart of a method for operating a device in the prevention of DVT according to one embodiment of the present invention. In step 602, a person such as a medical professional sets up the device with appropriate limits for range of motion and minimum time between ankle movements. This step 602 may also be performed automatically. Then, in step 604, a DVT prevention device is attached to one or both ankles of the patient, and if necessary the device is turned on. In step 606, a test is made to determine if too much time has elapsed since the last flexion of the ankle. If the predefined time limit between flexion has been exceeded, step 608 runs a device actuator through one flexion/extension cycle or other suitable sequence. This cycle may be purely passive motion, or the patient may actively resist tending to cause more blood flow. If the time limit has not been exceeded or if the cycle is at the end of the passive or active movement cycle, the actuator is put into free movement mode in step 610. Finally, in step 612, the movements of the ankle are monitored to help determine the appropriate time for the next movement. Step 612 is followed by step 606, repeating the sequence until the prevention method stops, the device is removed, or the device is turned off.

[0028] In the flowchart of FIG. 6, step 606 determines if the specified time has elapsed in order to initiate movement of the

ankle. The "specified time" can be determined by any suitable manner including one or more of any of the following ways:

- [0029] 1. A fixed elapsed time since the last ankle movement
- [0030] 2. A moving average over time of the frequency of ankle movements.
- [0031] 3. A dynamic algorithm that approximates blood flow in the leg by taking into account the frequency of movement, the intensity of active movement, and the patients age and condition.

[0032] A fixed time algorithm is simplest to implement, but may move the ankle more than necessary. Using a frequency of movement algorithm, the patient can have more control and has more positive feedback for initiating movements beyond the minimum. A dynamic algorithm rewards patient-initiated exercise (resisting the passive movement) and also customizes the frequency of movement based on the patient's condition. The algorithm can be determined through clinical studies of different patients using the device while monitoring blood flow.

[0033] The invention is not limited to the specific embodiments described. For example, actuators need only have a way to move and allow free movement of the ankle and need not have strictly linear movement. The actuator may be driven from a brushed or brushless motor or may be activated through pneumatics, hydraulics, piezoelectric activation, electro-active polymers or other artificial muscle technology. The usage of the device is not confined to hospitals but also may be beneficial to those bedridden in nursing homes or at home. The device may also be beneficial to avoid DVT for those traveling long distances by airplane, automobile or train.

I claim:

- 1. A device intended to reduce the incidence of deep vein thrombosis in a patient, the device comprising:
 - a portable power supply;
 - an embedded controller powered by the portable power supply;
 - an actuator with an output shaft, the actuator controlled by the embedded controller;
 - where the device has a free movement mode and a powered output mode;
 - a first attachment for coupling the actuator to a first portion of the patient; and
 - a second attachment for coupling the output shaft to a second portion of the patient.
- 2. The device of claim 1 further comprising a joint angle sensor.
- 3. The device of claim 1 further comprising a force sensor.
- 4. The device of claim 1 further comprising a wireless recharger for the portable power supply.

5. The device of claim 1 further characterized in that power recharging is performed by power generation resulting from ankle movement.

6. The device of claim 1 further comprising a connection port to communicate patient movement.

7. The device of claim 6 further characterized in that communication of patient movement is used to control the operation of a personal computer.

8. The device of claim 6 further characterized in that communication of patient movement is used to control the operation of an electronic game.

9. An actuator providing substantially free movement or force to an output shaft comprising:

- a motor driving a lead screw;
- a nut driven by the lead screw;
- an output shaft with at least one extension stop; and
- wherein the nut driven by the lead screw may be moved to a first position allowing substantially free movement of the output shaft and a second position in which the nut engages the at least one extension stop and causes the output shaft to extend.

10. The actuator of claim 9 including at least one flexion stop attached to the output shaft with the nut in a third position in which the nut engages the flexion stop and causes the output shaft to retract.

11. A method intended to reduce the incidence of deep vein thrombosis in a patient, the method including:

- configuring an ankle movement device with movement limits and frequency of operation;
- attaching the device to an ankle of a patient;
- determining a time interval between substantial ankle movements;
- moving the ankle via the device when a maximum time between movements has been exceeded; and
- allowing the ankle to move freely when the maximum time has not been exceeded.

12. The method of claim 11 in which the maximum time is a fixed elapsed time.

13. The method of claim 11 in which the maximum time is determined by a number of movements over a time period.

14. The method of claim 11 in which the maximum time is altered based on the patient's active resistance to the movement.

15. The method of claim 11 in which the maximum time is altered based on the condition of the patient.

16. The method of claim 11 in which the programmed range of motion increases over time based as the patient's range of motion increases.

* * * * *