

(No Model.)

4 Sheets—Sheet 1.

N. YAGN.

APPARATUS TO FACILITATE WALKING AND RUNNING.

No. 406,328.

Patented July 2, 1889.

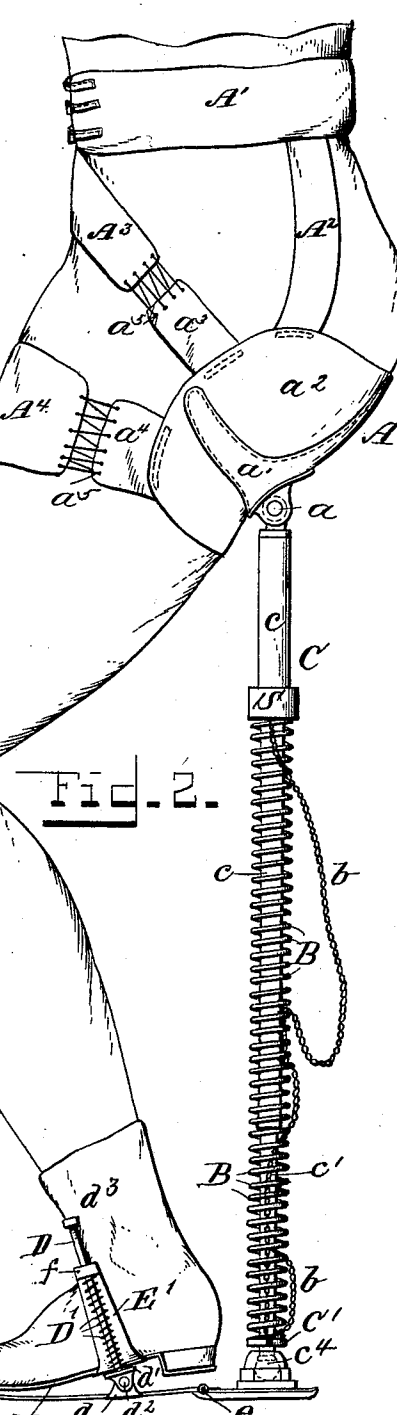
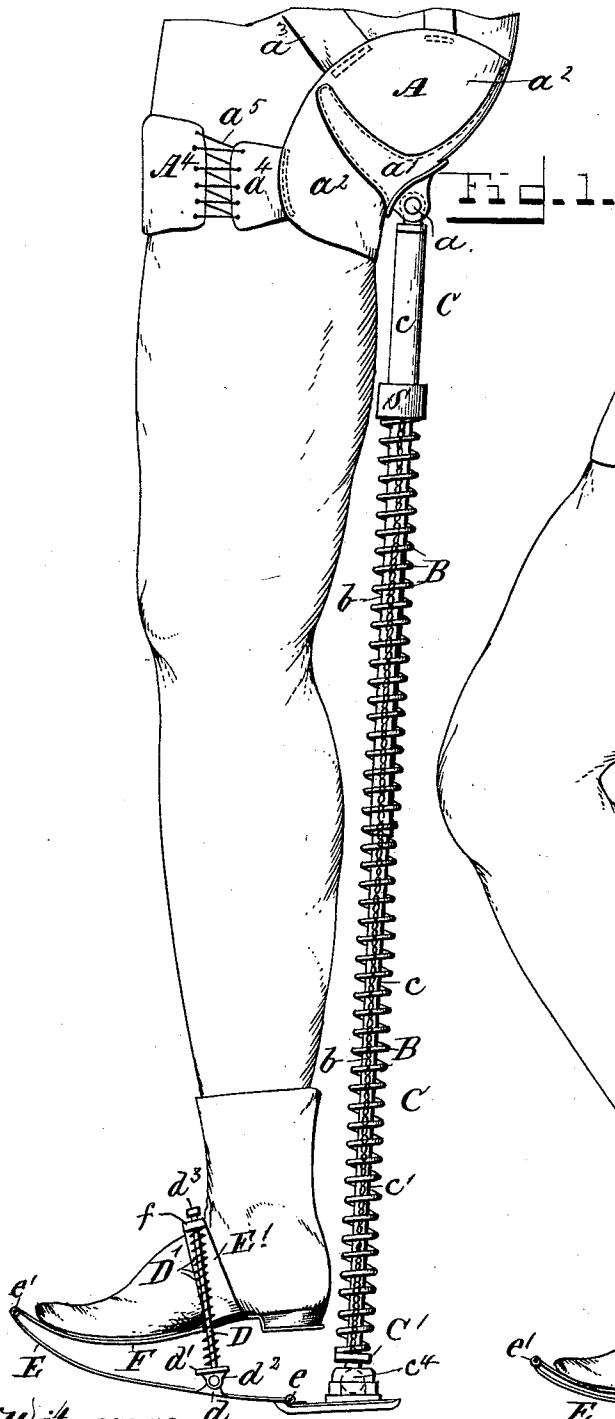

Witnesses:
J. Thomson Cross.
Wm. E. Rouze

Inventor:
Nicholas Yagn.
 per *Henry W. Th. Atty.*

(No Model.)

4 Sheets—Sheet 2.

N. YAGN.

APPARATUS TO FACILITATE WALKING AND RUNNING.

No. 406,328.

Patented July 2, 1889.

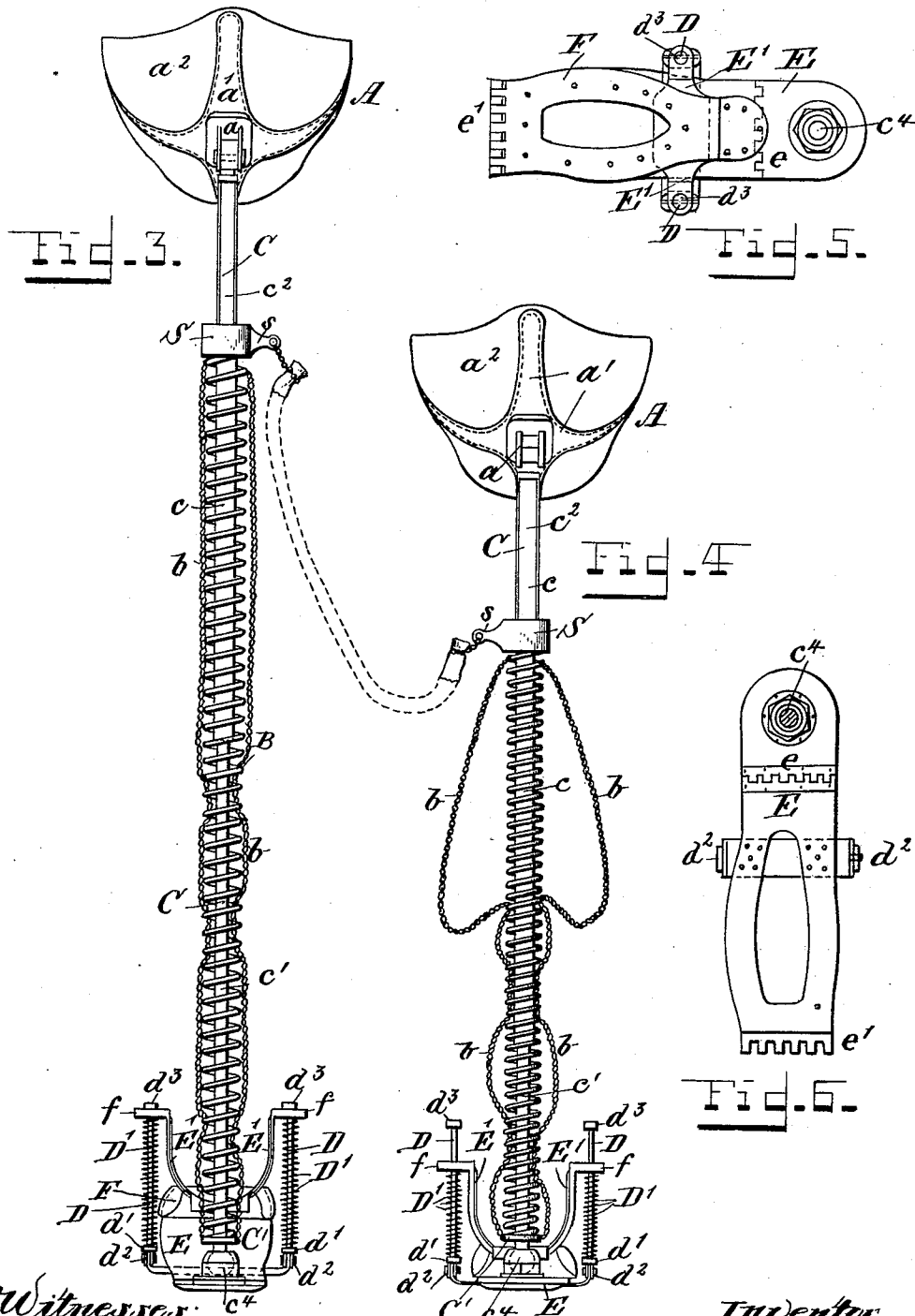

Witnesses:
J. Thomson Cross
Mill. & Rouze

Inventor:
Nicholas Yagn
 per *Henry O'Neil*
 Atty

N. YAGN.

APPARATUS TO FACILITATE WALKING AND RUNNING.

No. 406,328.

Patented July 2, 1889.

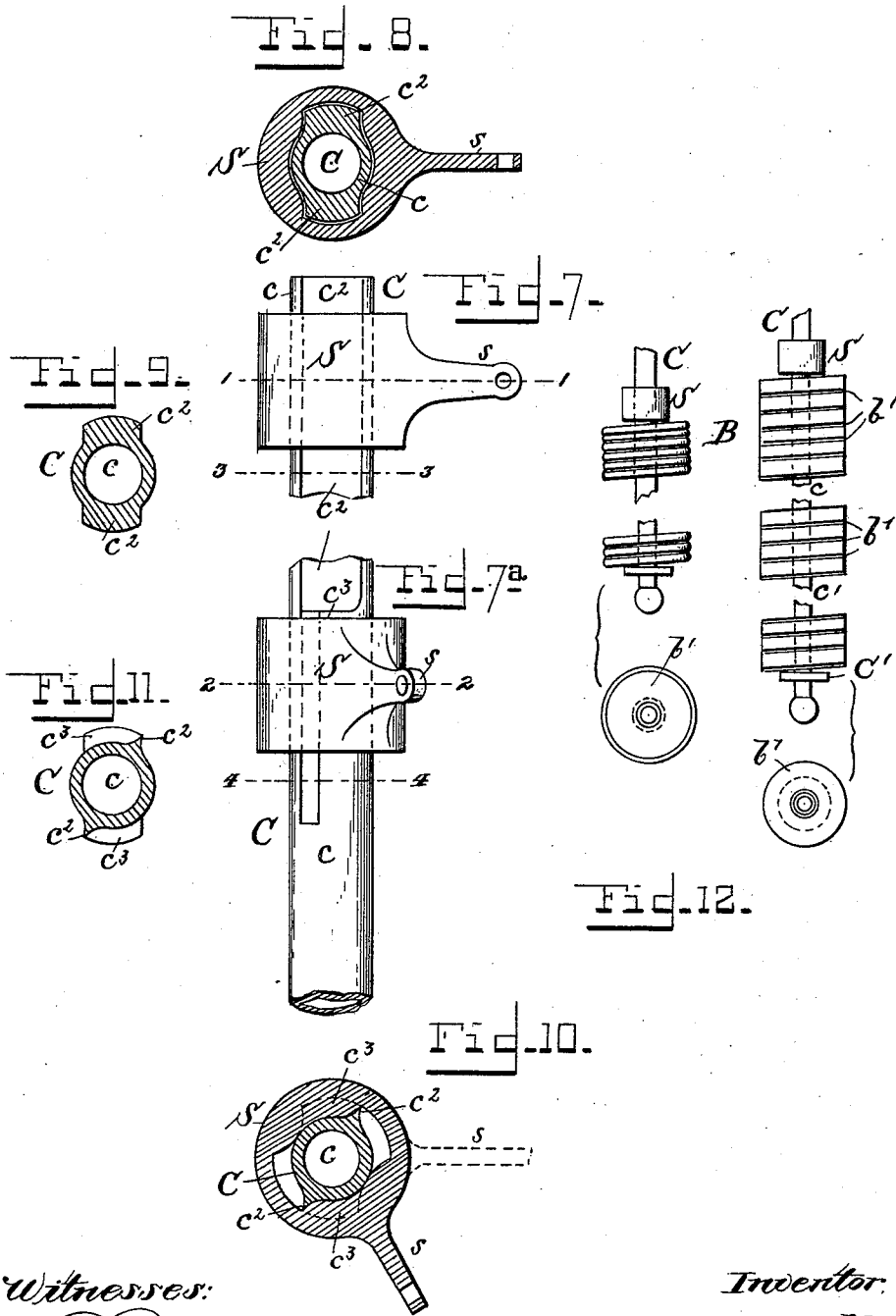

Witnesses:
Thomson Cross
Mill. E. Rouzee

Inventor:
Nicholas Yagn.
 per *Henry Orth*
H. O. Orth

N. YAGN.

APPARATUS TO FACILITATE WALKING AND RUNNING.

No. 406,328.

Patented July 2, 1889.

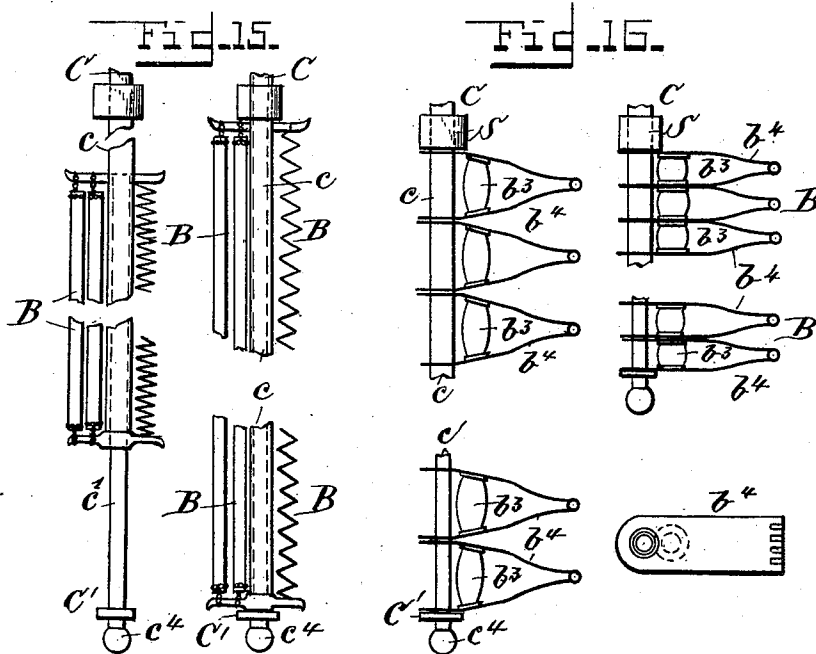
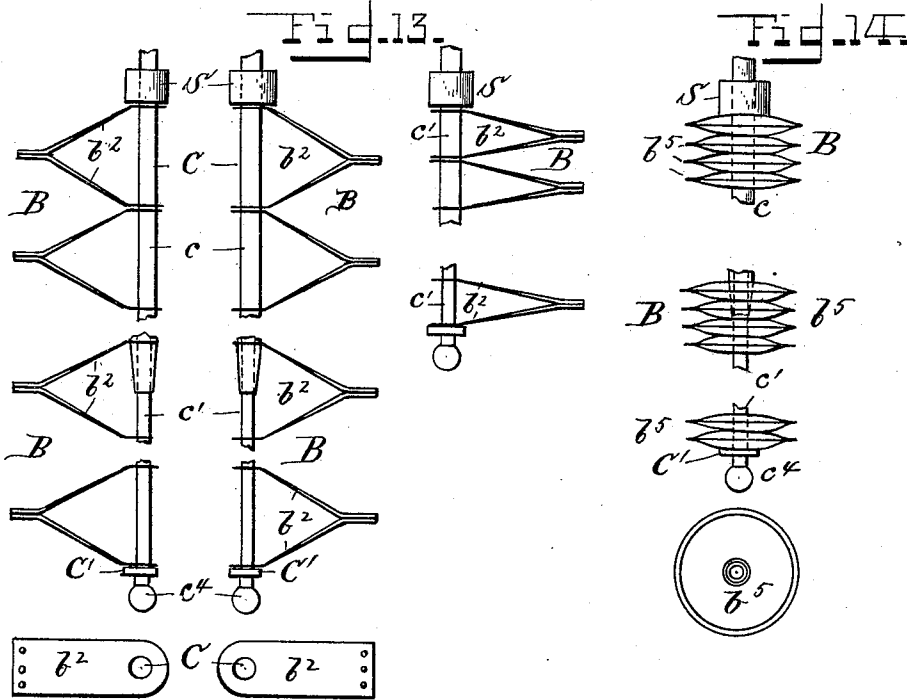

Witnesses:
J. Thomson Cross
Mill. E. Bouzee

Inventor:
Nicholas Yagn.
 per *Henry M. W. Atty.*

UNITED STATES PATENT OFFICE.

NICHOLAS YAGN, OF ST. PETERSBURG, RUSSIA.

APPARATUS TO FACILITATE WALKING AND RUNNING.

SPECIFICATION forming part of Letters Patent No. 406,328, dated July 2, 1889.

Application filed December 21, 1888. Serial No. 294,277. (No model.)

To all whom it may concern:

Be it known that I, NICHOLAS YAGN, a subject of the Emperor of Russia, residing at St. Petersburg, in the Empire of Russia, have invented certain new and useful Improvements in Apparatus to Facilitate Walking and Running; and I do hereby declare the following to be a full, clear, and exact description of the invention, such as will enable others skilled in the art to which it appertains to make and use the same, reference being had to the accompanying drawings, and to the letters or figures of reference marked thereon, which form a part of this specification.

Referring to the drawings, Figures 1 and 2 illustrate in side elevation my improved apparatus in its application for use and in different positions. Figs. 3 and 4 are rear elevations of the same in the positions shown in Figs. 1 and 2, respectively. Figs. 5 and 6 show, respectively, the shoe and foot-rest thereof in plan view. Figs. 7 and 7^a are elevations of a portion of the telescopic rod or standard of the apparatus and the locking-sleeve. Figs. 8 and 9 are sections taken, respectively, on lines 1 1 and 2 2 of Fig. 7. Figs. 10 and 11 are like views looking upwardly and taken, respectively, on lines 3 3 and 4 4 of Fig. 7^a. Figs. 12, 13, 14, 15, and 16 illustrate by elevations and plan views several modifications in the form and construction of power-spring.

The fatigue inherent to the simple bending or flexure of the legs when otherwise motionless is well known, as well as the reason why the power exerted by the muscles of the legs is greater than in walking or running. In the former case there is no useful mechanical product or result of the force expended other than the mere lifting of the trunk or body, while in the latter case there is a comparatively great or useful mechanical product or result obtained in the propulsion of the body; yet there is in the latter case a comparatively great amount of energy wasted in overcoming the inertia of the body. It is obvious, therefore, that walking, running, jumping, or the carrying of burdens could be rendered much less fatiguing if the energy or power required to sustain the body or the latter and a burden could be taken up by mechanical devices, and that the speed in walking or running or

the distance at a jump may be materially increased if the mechanical power necessary to the support of the body were so constructed as to be multiplied in proportion to the *vis viva* of the dead-weight of the body when in motion, and this is the object of the present invention.

The invention consists of a spring-support for the body and adapted to be secured to the legs and operating to relieve the latter of the weight of the body, or such weight and an additional weight or burden carried by the body, substantially as hereinafter described, and as set forth in the claims.

The invention further consists in the combination, with the spring-support for the body, of a like support for the legs to assist the latter in carrying the weight of the body and in overcoming the inertia thereof, substantially as hereinafter fully described, and set forth in the claims.

Finally, the invention consists in structural features and combinations of parts, substantially as hereinafter fully described, and as set forth in the claims.

Before describing my invention in detail I would state that two apparatuses of precisely the same construction are employed and to be applied to both the legs of the wearer. It will therefore only be necessary to describe one in order that the invention may be fully understood.

The apparatus consists, essentially, of three parts—a telescopic standard provided with a saddle, a power-spring, and a shoe to which said standard is connected.

The saddle A consists of a three-armed frame *a'*, of wood, metal, or other suitable material, provided with one half of a hinge *a*, the other half of which is formed upon the upper end of the standard. The saddle-cloth *a*² of both apparatuses is connected by a strap A² to a waist-belt A' and to each other by a belly-band A³, one of the saddles being provided with a short strap or tongue *a*³, Figs. 1 to 4, and each saddle is further provided with a thigh-strap A⁴, adapted to be connected to a short strap or tongue *a*⁴.

In the drawings I have shown the parts A³ and *a*³ and A⁴ *a*⁴ adjustably connected together by means of lacing *a*⁵; but other well-known means may be employed to adjust these

parts to the body of the wearer, and in practice I preferably make the straps A^2 adjustable also relatively to the belt and saddle.

The belly-band A^3 is supported from the waist-belt by a hook or hooks or by a loop or loops. (Not shown.) Any other means may, however, be resorted to to secure the saddles to the upper end of the legs, so that when the legs are flexed or bent the weight of the body will be thrown on and supported by the saddles, as shown in Fig. 2.

The standard C is composed of two telescopic sections c and c' , the lower section c' being connected by a universal joint c^1 to the heel end of a shoe, presently to be described, while the upper end of the section c of said standard has the half-hinge for the saddle hereinbefore referred to.

The upper section c of standard C is provided for a portion of its length and on diametrically-opposite sides with longitudinal ribs c^2 , that terminate in a shoulder c^3 , said shoulder being formed by cutting away the ribs in opposite directions, as shown in Figs. 7 and 11, and upon this section of the standard is mounted a sleeve S , that corresponds in cross-section to the ribbed portion of the standard-section c , as shown in Figs. 8, 9, and 10. It is obvious that when said sleeve S is allowed to slide along the standard-section c until its upper edge lies below the cut-away portion of the said ribs and a partial rotation is imparted to the sleeve it will be moved out of register with the ribs and be thus locked against upward motion by the shoulders c^3 . At the lower end, above the universal joint c^1 of section c' of the standard, is secured a disk C' , that together with the sleeve S serve as abutments for a coiled spring B , mounted on standard C , which spring holds the sleeve S by a yielding pressure against downward motion. To limit the expansion of the spring, I employ cords or chains b , attached to disk C' and to the spring at its upper end, as shown, or to the sleeve S , and to prevent said chains from becoming entangled in the coils of the spring when said spring is compressed or expanded they may be passed through or woven into the coils at certain points, as shown in Figs. 1 to 4.

E , Figs. 1 to 6, is the shoe, to the heel end of which the standard is mounted, as described, said shoe being hinged or articulated at the instep, as shown at e , Figs. 5 and 6. To the toe end e' of the shoe is hinged or articulated a foot-rest F , that is supported from the shoe E by a stirrup F' , secured to the foot-rest at or near the instep thereof, said stirrup being provided with perforated lugs or ears f , that are adapted to slide on vertical rods D , hinged at d^2 to a cross bar or plate d^1 , secured to the shoe E in front of the instep thereof.

As shown in Figs. 1 and 2 and in Fig. 5, the shoe is considerably longer than the foot-rest, so as to provide room for connecting the standard C . Upon each rod D is mounted a spring

D' , whose lower end abuts against a disk or flange d' and its upper end against one of the lugs or ears f of the stirrup F' , the upper ends of the rods being provided with a head or flange d^3 to confine the stirrup and springs.

In each of a coiled spring, any other suitable form of power-spring may be employed.

In Fig. 12 I have shown a spring composed of a rubber coiled spring and metallic disks b' , or a metallic coiled ribbon interposed between the rubber coils.

Fig. 13 shows a spring composed of a series of half-elliptic springs b^2 , through the free end of which the standard C passes.

Fig. 14 shows a spring constructed on the principle of the Belleville system—that is to say, the spring is formed by elastic concavo-convex disks b^3 .

Fig. 15 shows a plurality of coiled springs connected with radial arms secured to the lower section c' of the standard C , at the upper and lower ends of said section, respectively, the upper section c of the standard being suitably slotted for the passage of the arms and to enable said sections to move one upon the other.

Fig. 16 shows a spring composed of sections comprising each two non-elastic metallic plates b^4 and a rubber block b^5 , interposed between said plates, through the free end of which the standard C passes. The power-spring employed may thus be varied according to the power to be exerted by such spring.

The operation of my improved device is as follows: When the leg is in a perfectly erect position, as shown in Fig. 1, the sleeve S is locked by the shoulder c^3 against upward motion on the standard, and the leg cannot be bent, owing to the stress of the spring. I have hereinbefore stated that by imparting a partial rotation to the sleeve S its bore can be made to register with the ribs c^2 on the upper standard-section, and that this may be effected automatically and at the proper time the sleeve S is provided with an arm s , and the arms of both sleeves are connected by a coiled spring or elastic band or cord, and in such manner that on moving one leg forward, as in walking, the sleeve S on the standard of the other leg will be partially rotated to permit the sleeve to move upward, so that said leg may be bent to move it off the ground prior to throwing it forward, the extent of motion of the sleeve being a limited one. Supposing that the wearer of the apparatus starts with the left leg, the sleeve on the standard of that leg having been previously turned to allow the leg to be bent, as said leg is thrown forward the sleeve on the right leg is turned; but as the left leg is straightened to bring it to the ground the standard thereof is extended to its full length, and as the sleeve on said standard is held by the stress of the elastic connection the upper standard-section will move sufficiently to bring the shoulder c^3 above the sleeve and thus lock it. As the left

foot reaches the ground and the right leg is bent for the next step, the entire weight of the body is supported from the coiled spring of the standard on the left leg, instead of on said leg. Said spring is compressed and will assist the wearer in his effort to lift the right leg previous to taking the next step. Now, if the propulsion of the body is effected by jumps, the *vis viva* or momentum of the body is converted into lifting power by the spring B. The power of this spring is assisted by the power exerted by the springs D', and their resistance to compression should be such as that when the full weight of the body is supported thereby the heel of the boot or shoe of the person will not quite touch the shoe E, as shown in Fig. 2. It will readily be seen that the weight of the body is not only taken up by the springs B D', but is made the means of multiplying the power to be exerted by said springs in proportion to the *vis viva* of the body when in motion, so that the muscles of the legs are substantially relieved of all strain.

In practice the heel of the foot-rest may be provided with spikes or screws to be secured to the heel of the boot or shoe of the wearer, as is the case in skates; or other means may be provided, such as straps and buckles connected with the stirrups.

The elastic foot-rest may be dispensed with and the shoe E attached to the shoe of the wearer; but I prefer to use the foot-rest, as it materially assists in relieving the muscles of the legs from the strain and the spinal column from being jarred, especially in running or jumping.

What I do claim as my invention, and desire to secure by Letters Patent, is—

1. In an apparatus of the class described, a spring-support for the body and pivotal connections for connecting the opposite extremes of the support to the corresponding extremes of the legs, substantially as and for the purposes specified.

2. In an apparatus of the class described, a spring-support for each leg, comprising a telescopic standard, a power-spring having its extremes connected with the extreme sections of the standard, a seat or bearing for connecting the standard to the upper extreme of the leg, and a pivotal connection between the lower extreme of said standard and the foot, substantially as and for the purposes specified.

3. In an apparatus of the class described, a spring-support for each leg, comprising a telescopic standard, a seat or bearing for connecting the standard to the upper extreme of the leg, a pivotal connection between the lower extreme of the standard and the foot, a power-spring, a fixed abutment on the lower section of said standard for one end of the spring, a movable abutment for the opposite end of the spring on the upper section of the standard, and a lock for locking said abutment against motion, substantially as and for the purposes specified.

4. In an apparatus of the class described, a spring-support for each leg, comprising a telescopic standard, a seat or bearing for connecting the standard to the upper extreme of the leg, a pivotal connection between the lower extreme of the standard and the foot, a power-spring, a fixed abutment on the lower section of said standard for one end of the spring, a movable abutment for the opposite end of the spring on the upper section of the standard, a lock for locking said abutment against motion, and a connection between the movable abutments of the two standards operating to automatically lock and unlock the abutments in the act of walking, running, or jumping, substantially as described.

5. In an apparatus of the class described, the combination, with a spring-support for each leg, of a seat at one end thereof for attachment to the upper extreme of the leg, and a shoe at the opposite end of said support for attachment to the foot, substantially as described.

6. In an apparatus of the class described, the combination, with a spring-support for each leg, of a seat hinged at one end thereof for attachment to the upper extreme of the leg, and a shoe pivotally connected with the other end of said support and adapted to be attached to the foot, substantially as and for the purposes specified.

7. In an apparatus of the class described, the combination, with a spring-support for each leg, of a seat hinged at one end thereof for attachment to the upper end of the leg, a shoe articulated at the instep, and a universal joint between the heel of the shoe and the lower end of the support, substantially as and for the purposes specified.

8. In an apparatus of the class described, the combination, with a spring-support for each leg, a hinge-connection for attaching the upper end of said support to the upper extreme of the leg, a shoe pivotally connected with the lower end of the support, and an elastic foot-rest connected with the shoe, substantially as and for the purposes specified.

9. In an apparatus of the class described, the combination, with a spring-support for each leg, a connection for attaching the upper end thereof to the upper extreme of the leg, and a shoe articulated at the instep and pivotally connected with the support, of an elastic foot-rest consisting of a plate or sole articulated to the shoe at the toe, a stirrup connected with the foot-rest at the instep, and spring-bearings for said stirrup pivotally connected with the shoe, substantially as and for the purposes specified.

10. In an apparatus of the class described, the combination, with a spring-support for each leg, a connection for attaching the upper end thereof to the upper extreme of the leg, and a shoe articulated at the instep and pivotally connected with the support, of an elastic foot-rest consisting of a plate or sole ar-

ticulated to the shoe at the toe, a stirrup connected with the foot-rest at the instep, and spring-bearings composed of a rod hinged to the shoe on opposite sides thereof, and springs
5 mounted on said rods and supporting the stirrup, substantially as and for the purposes specified.

In testimony whereof I affix my signature in presence of two witnesses.

NICHOLAS YAGN.

Witnesses:

N. TSCHEKALOFF,
J. FRESHVILLE.