



US 20070123997A1

(19) **United States**

(12) **Patent Application Publication**  
**Herr et al.**

(10) **Pub. No.: US 2007/0123997 A1**

(43) **Pub. Date: May 31, 2007**

(54) **EXOSKELETONS FOR RUNNING AND WALKING**

(75) Inventors: **Hugh M. Herr**, Somerville, MA (US); **Conor Walsh**, Cambridge, MA (US); **Daniel Joseph Paluska**, Somerville, MA (US); **Andrew Valiente**, Chicago, IL (US); **Kenneth Pasch**, Dover, MA (US); **William Grand**, Roxbury, MA (US)

Correspondence Address:

**CHARLES G. CALL**  
**68 HORSE POND ROAD**  
**WEST YARMOUTH, MA 02673-2516 (US)**

(60) Provisional application No. 60/736,929, filed on Nov. 15, 2005. Provisional application No. 60/666,876, filed on Mar. 31, 2005. Provisional application No. 60/704,517, filed on Aug. 1, 2005. Provisional application No. 60/705,651, filed on Aug. 4, 2005. Provisional application No. 60/704,517, filed on Aug. 1, 2005.

**Publication Classification**

(51) **Int. Cl.**  
*A61F 2/74* (2006.01)  
(52) **U.S. Cl.** ..... **623/27**; 602/16; 602/23

(73) Assignee: **Massachusetts Institute of Technology**, Cambridge, MA (US)

(57) **ABSTRACT**

(21) Appl. No.: **11/600,291**  
(22) Filed: **Nov. 15, 2006**

**Related U.S. Application Data**

(63) Continuation-in-part of application No. 11/395,448, filed on Mar. 31, 2006.  
Continuation-in-part of application No. 11/499,853, filed on Aug. 4, 2006, and which is a continuation-in-part of application No. 11/395,448, filed on Mar. 31, 2006.  
Continuation-in-part of application No. 11/495,140, filed on Jul. 29, 2006, and which is a continuation-in-part of application No. 11/395,448, filed on Mar. 31, 2006.

An exoskeleton worn by a human user consisting of a rigid pelvic harness worn about the waist of the user and exoskeleton leg structures each of which extends downwardly alongside one of the human user's legs. The leg structures include hip, knee and ankle joints connected by adjustable length thigh and shin members. The hip joint that attaches the thigh structure to the pelvic harness includes a passive spring or an active actuator to assist in lifting the exoskeleton and said human user with respect to the ground surface upon which the user is walking and to propel the exoskeleton and human user forward. A controllable damper operatively arresting the movement of the knee joint at controllable times during the walking cycle, and spring located at the ankle and foot member stores and releases energy during walking.

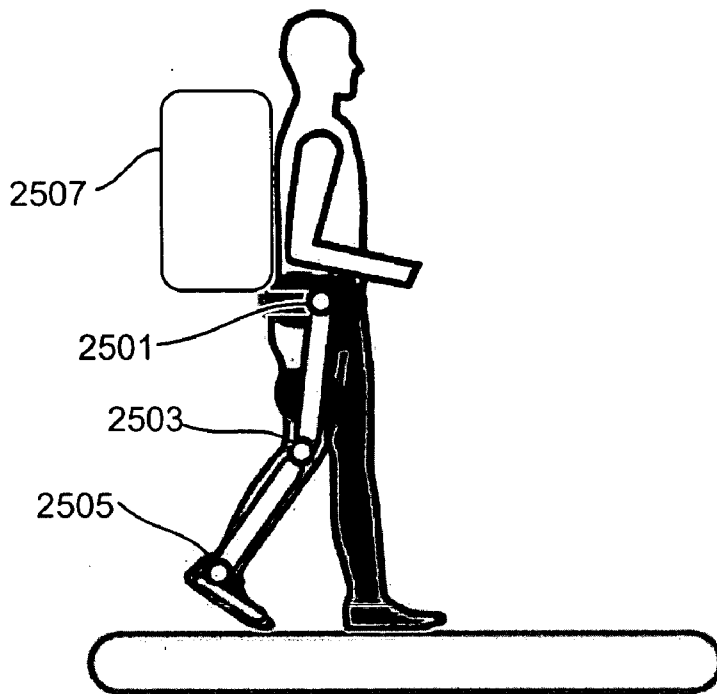

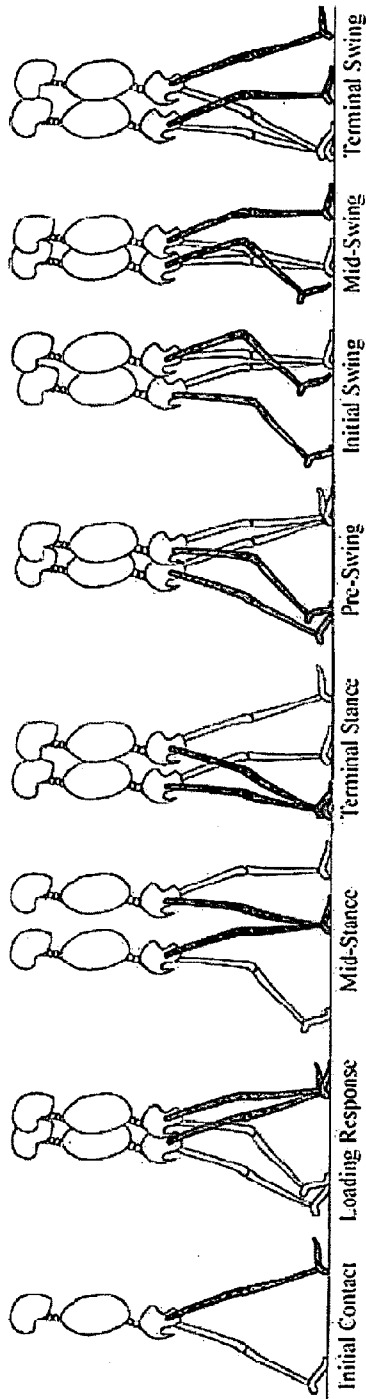

Fig. 1

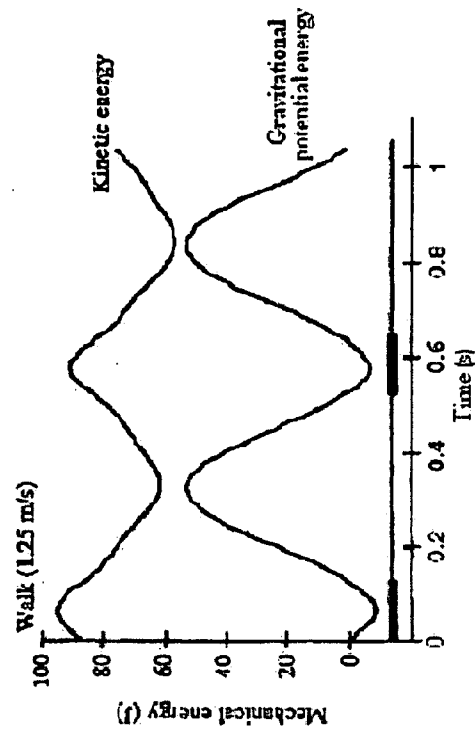

Fig. 3

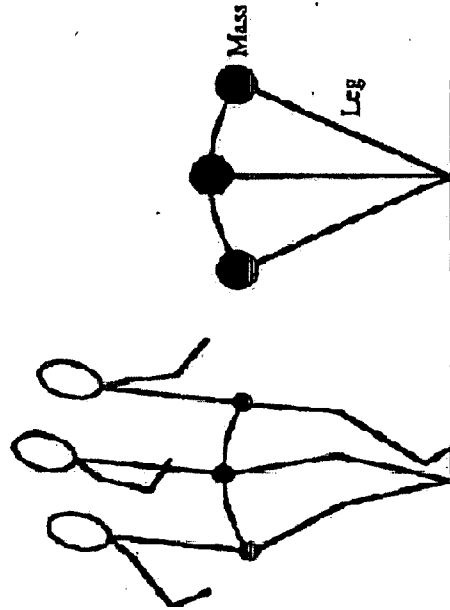

Fig. 2

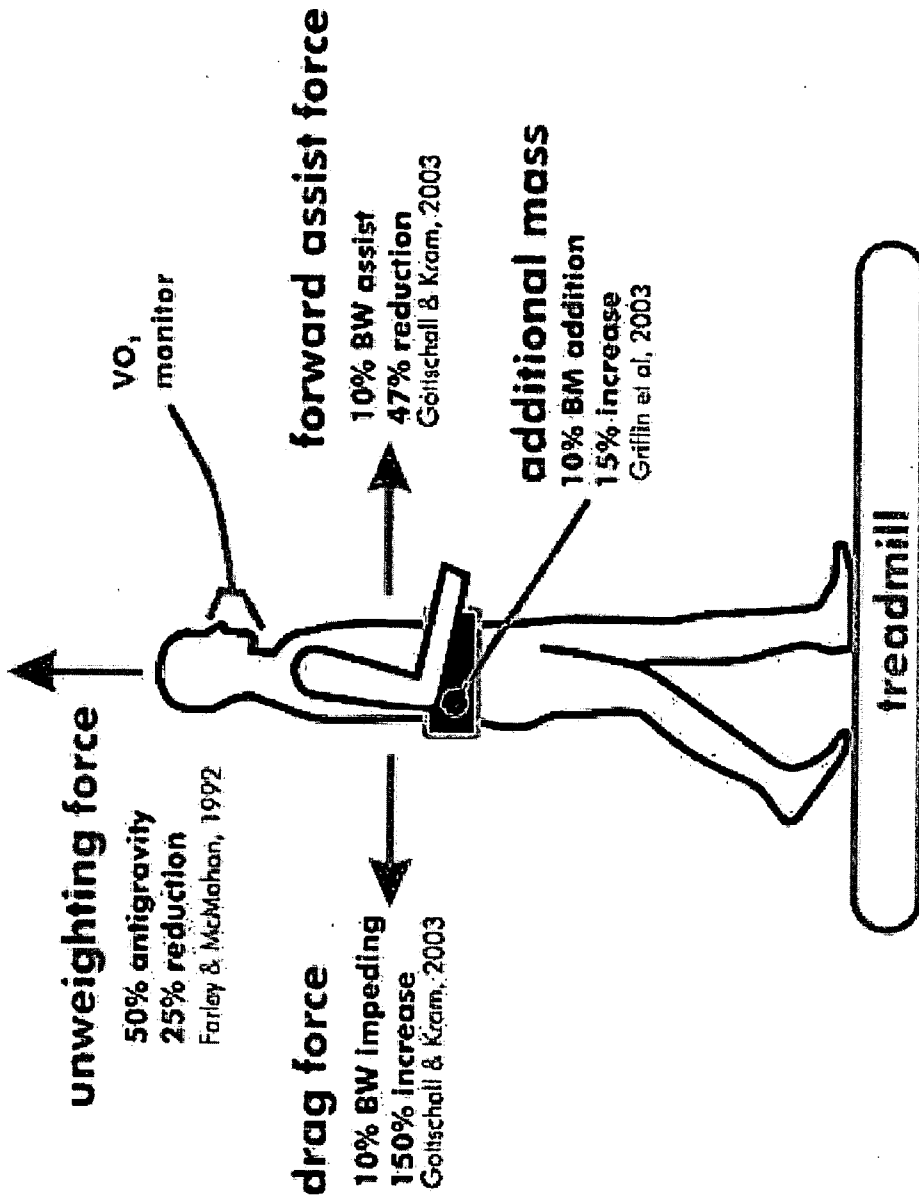

Fig. 4

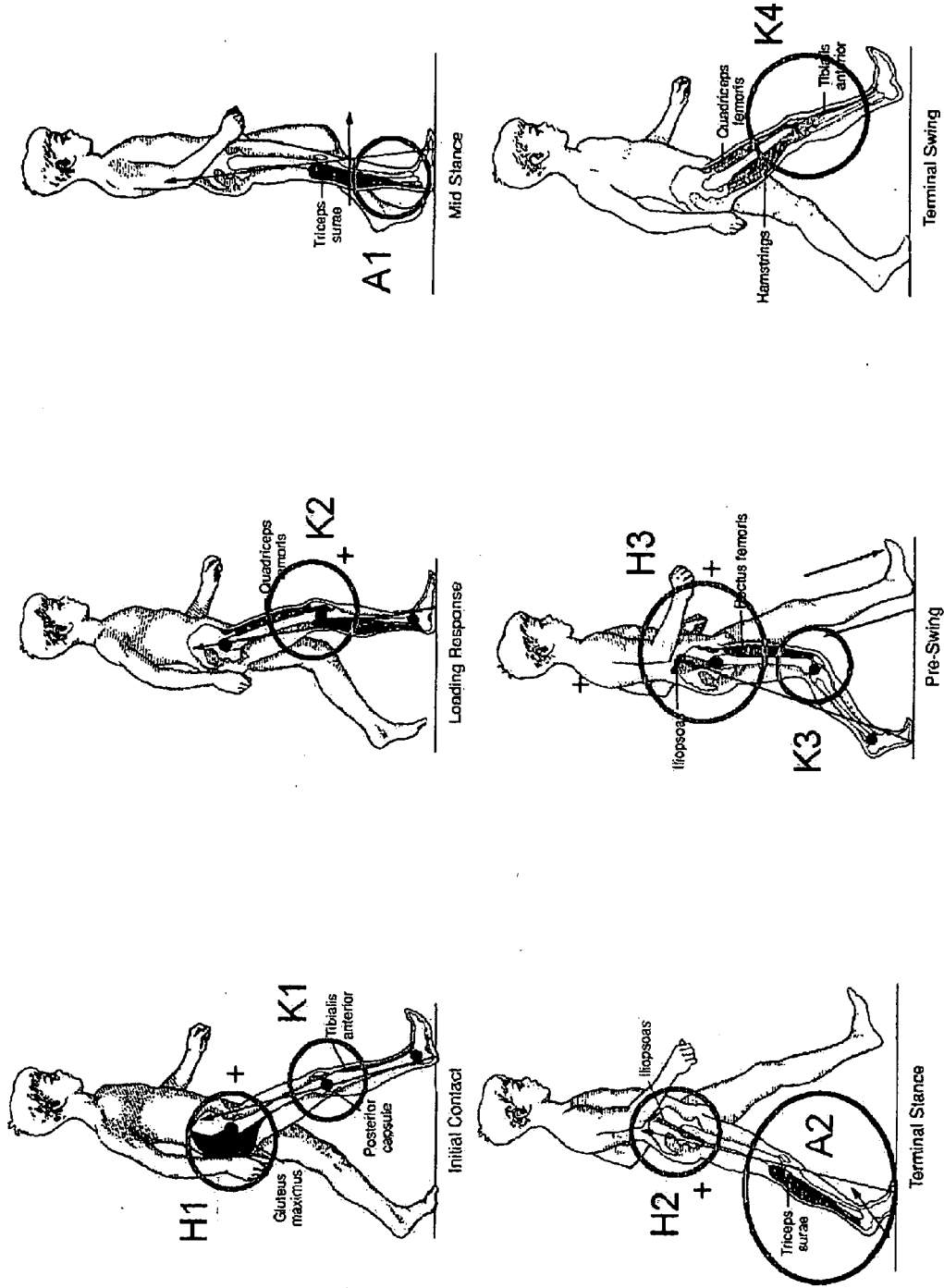

Fig. 5

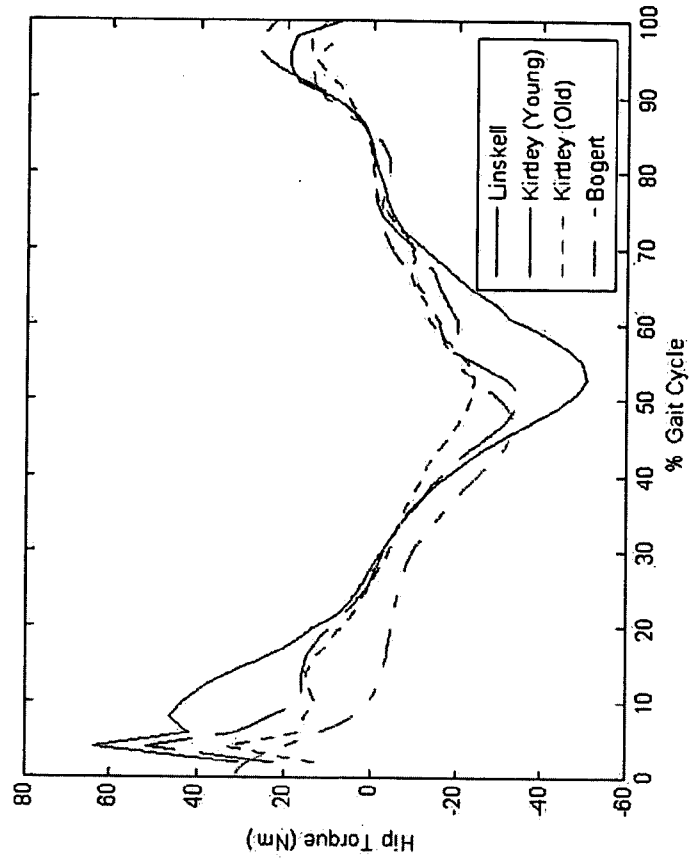

Fig. 7

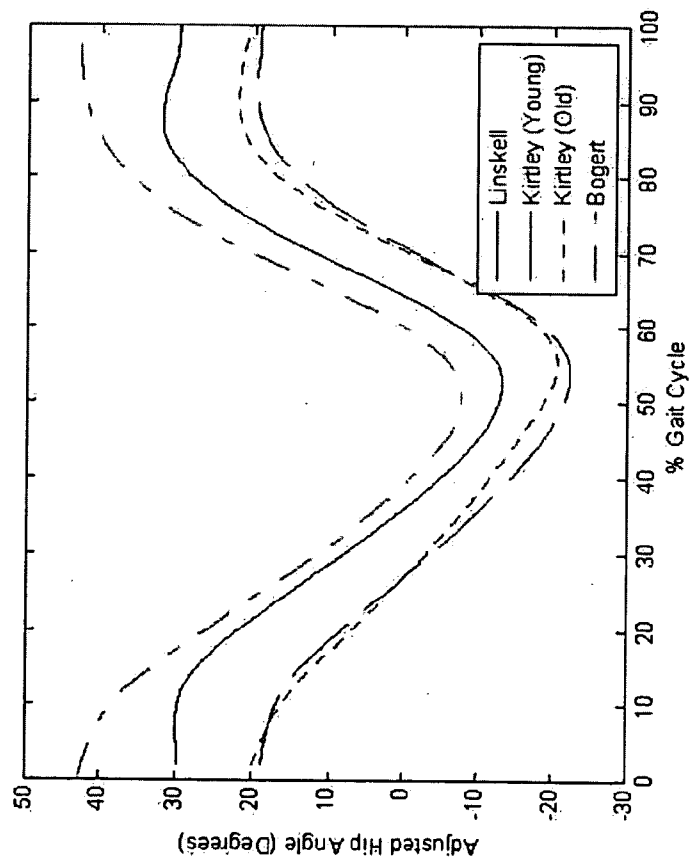

Fig. 6

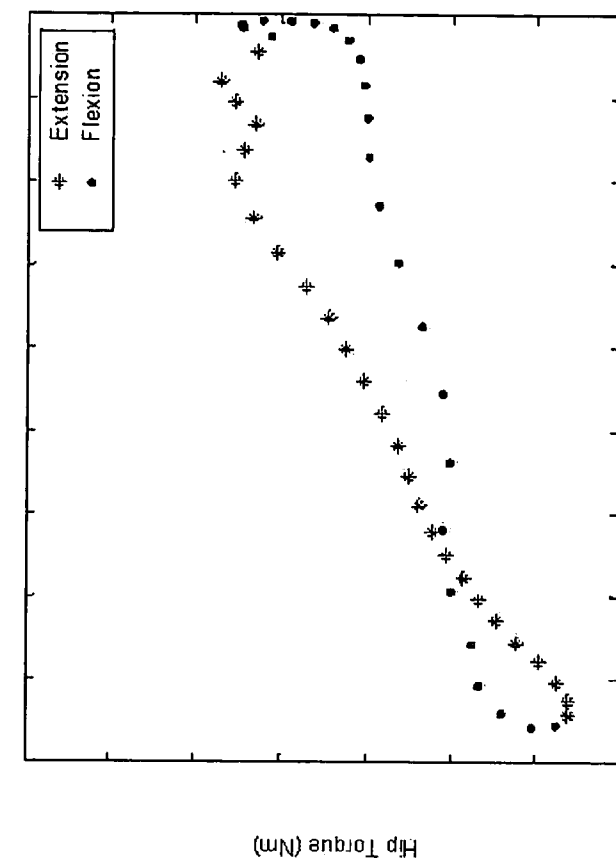

Fig. 9

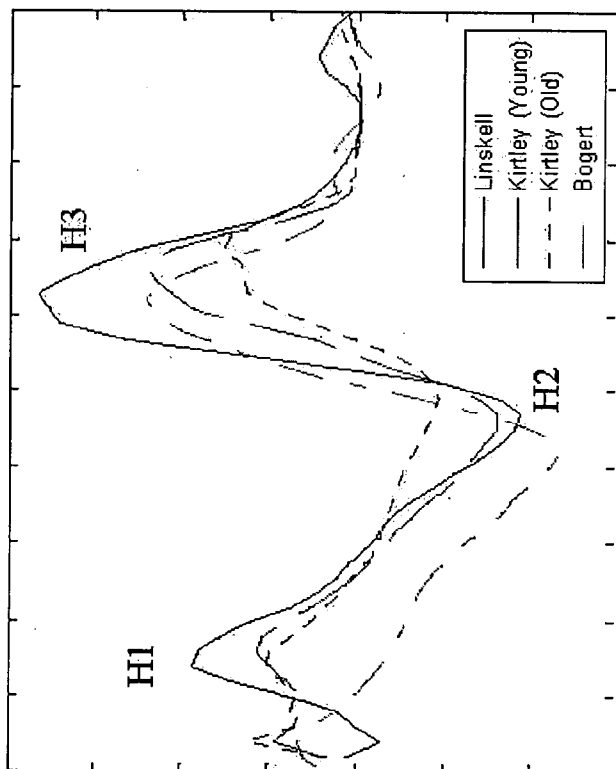

Fig. 8

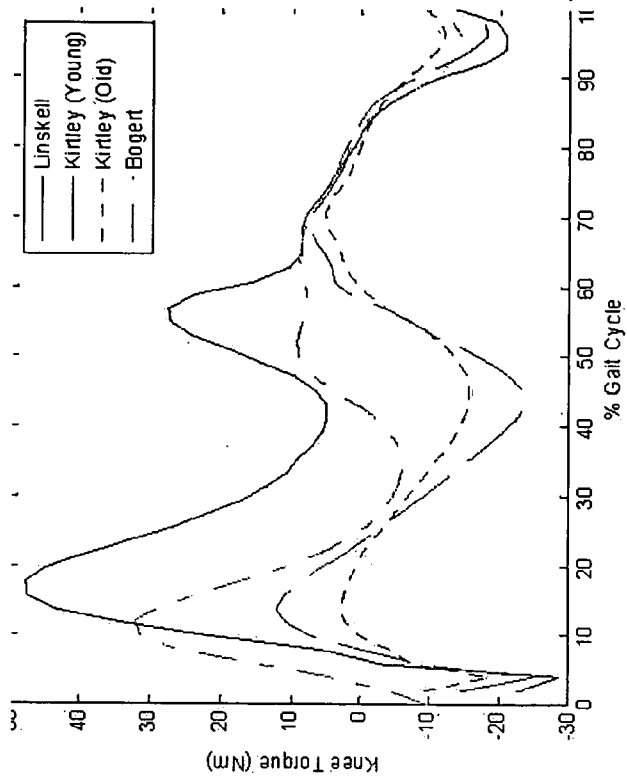

Fig. 17

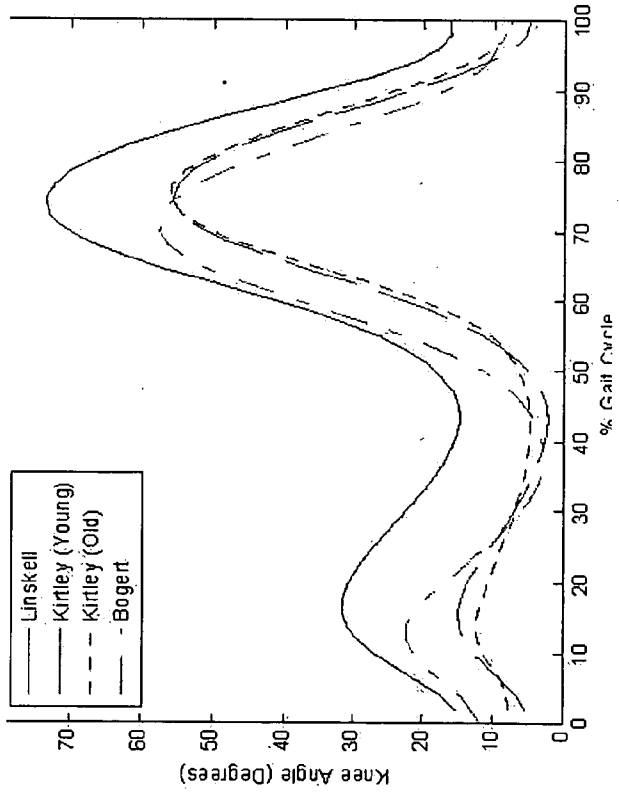

Fig. 10

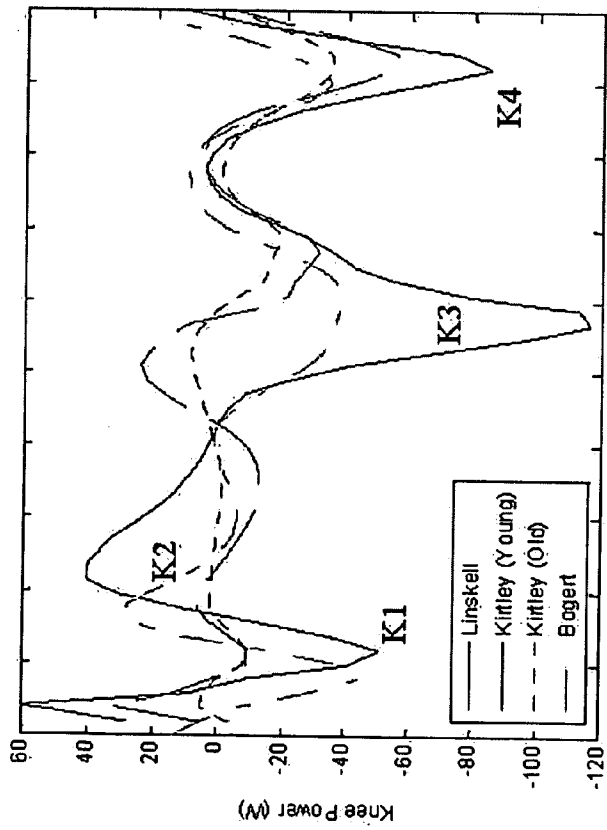
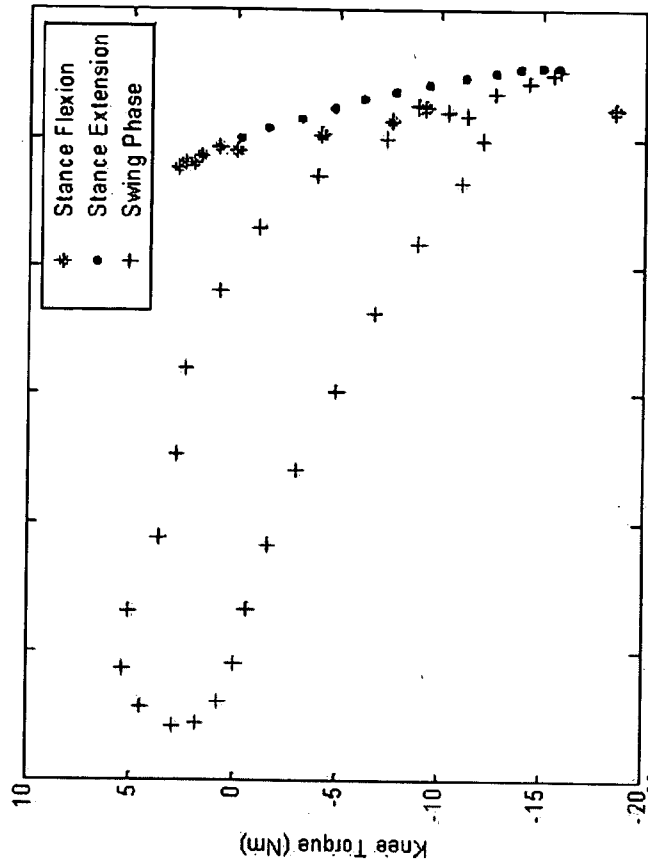

Fig. 13

Fig. 12



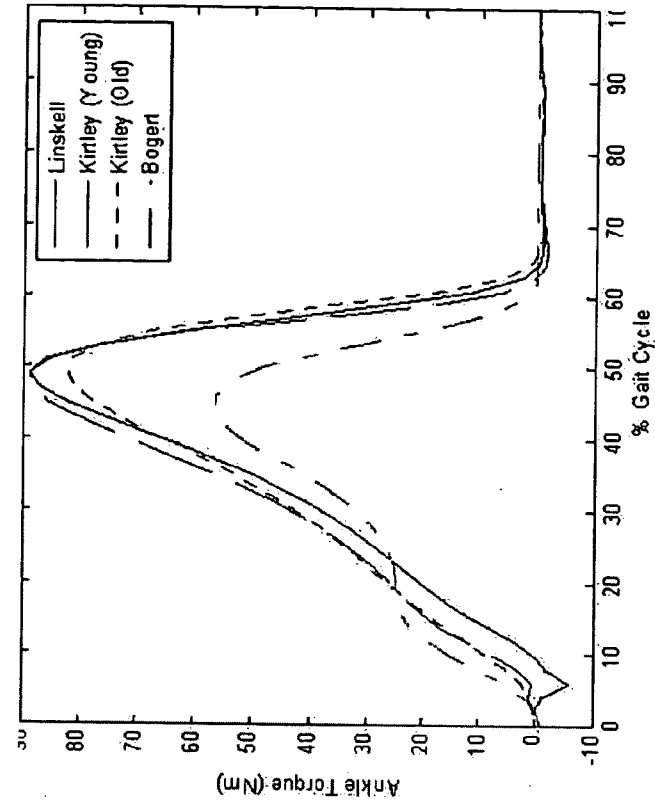

Fig. 15

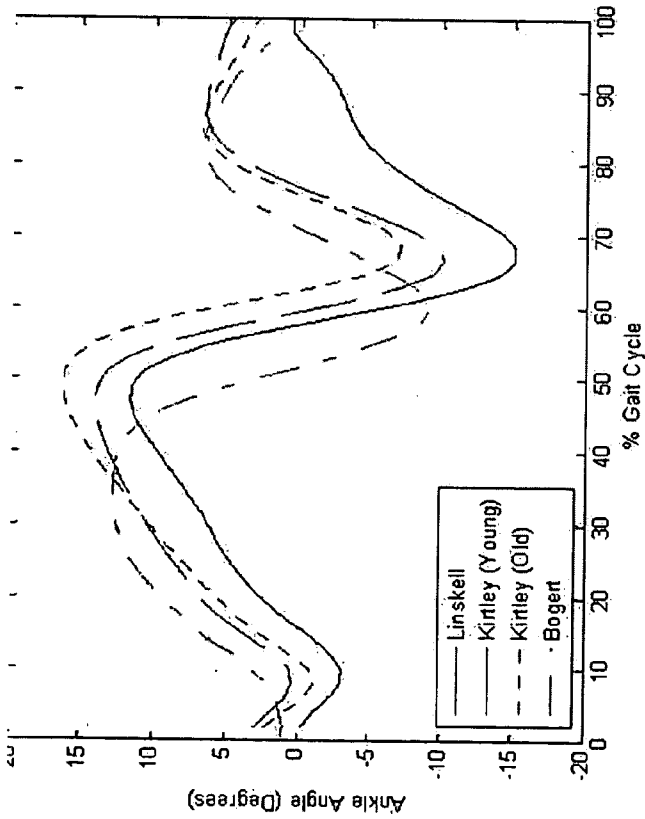

Fig. 14

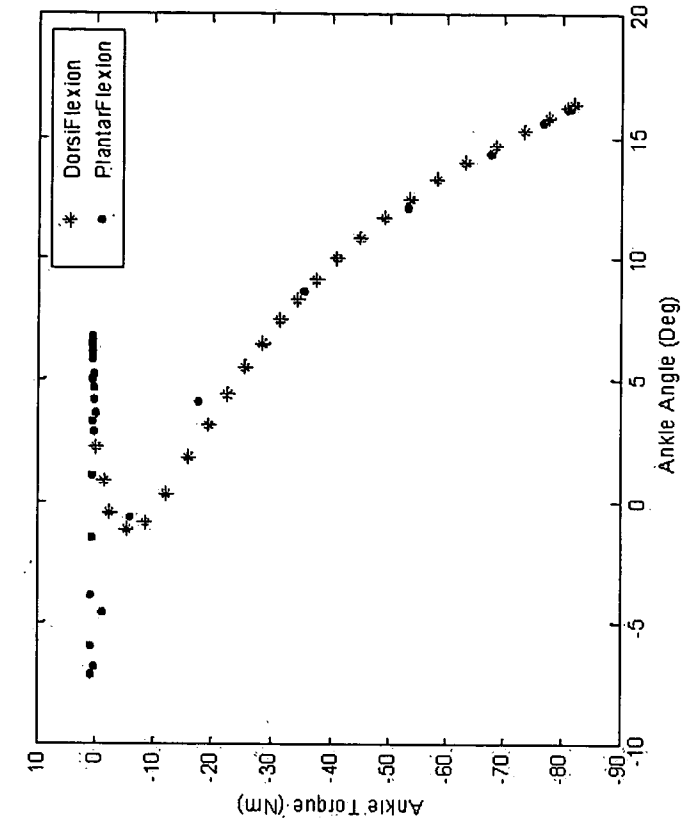

Fig. 17

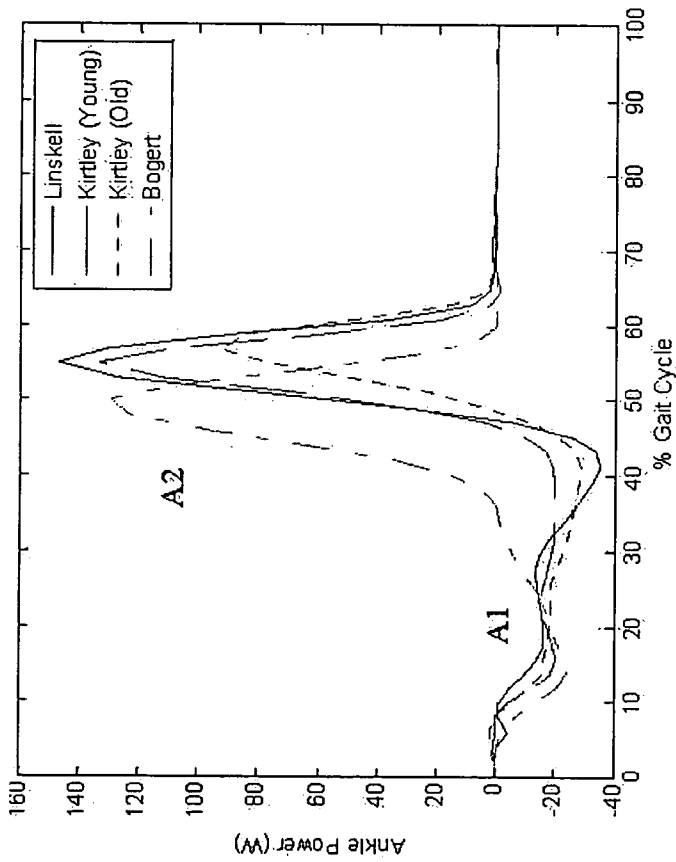

Fig. 16

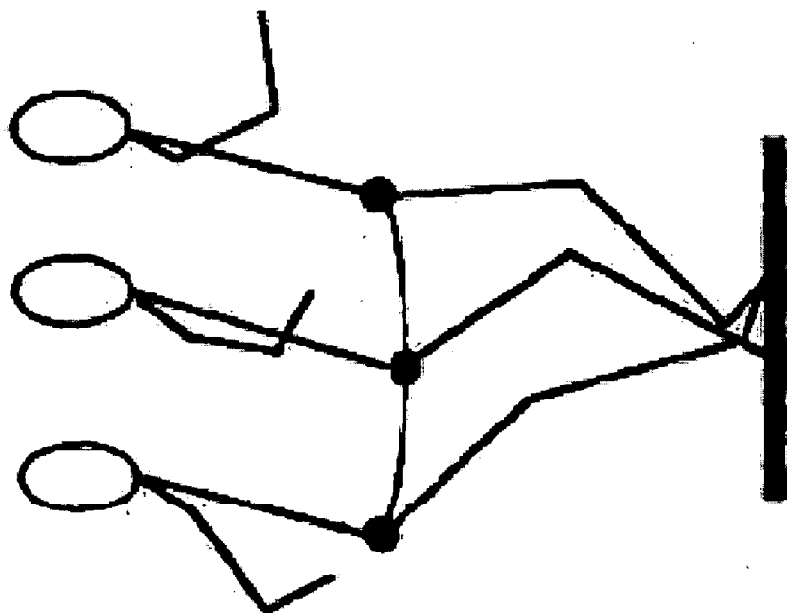

Fig. 18

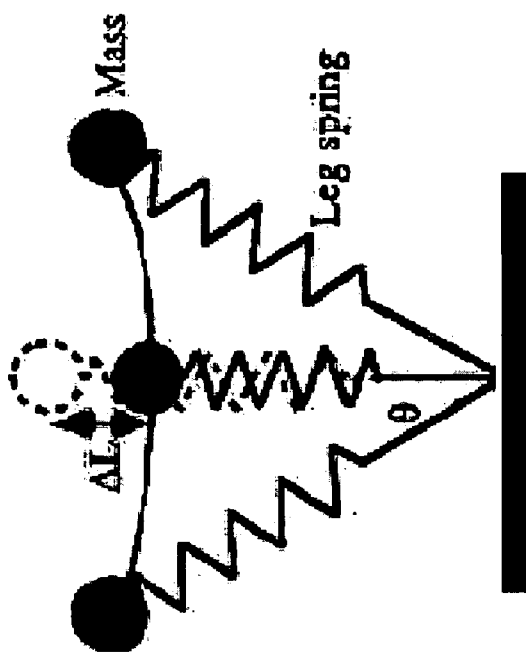

Fig. 19

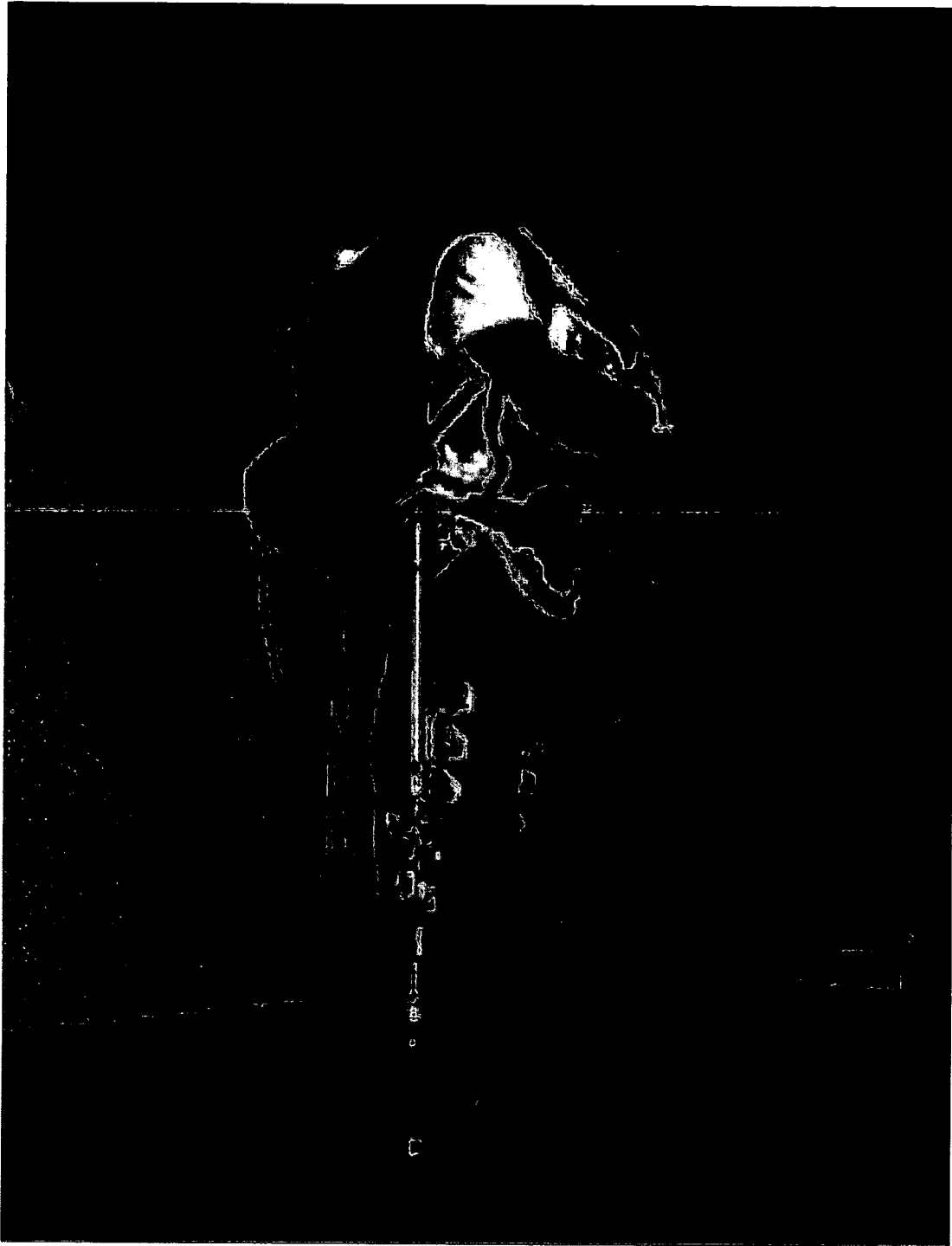

Fig. 20



Fig. 21

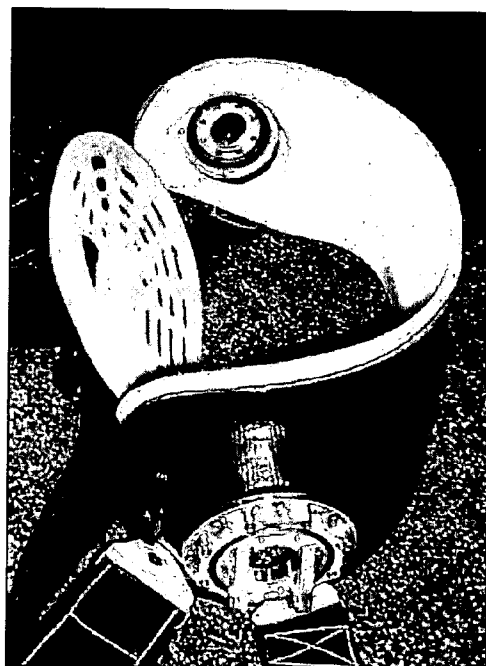

Fig. 22

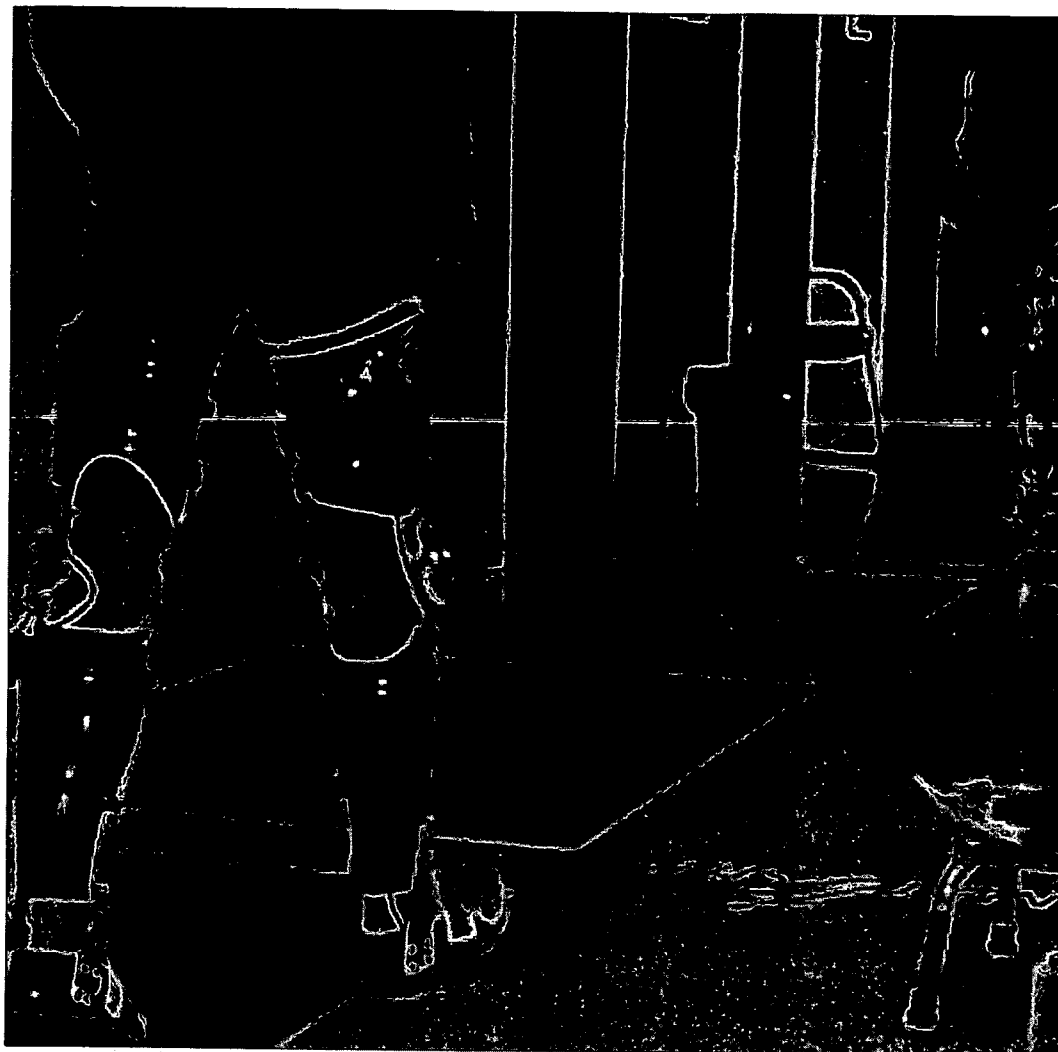

Fig. 23

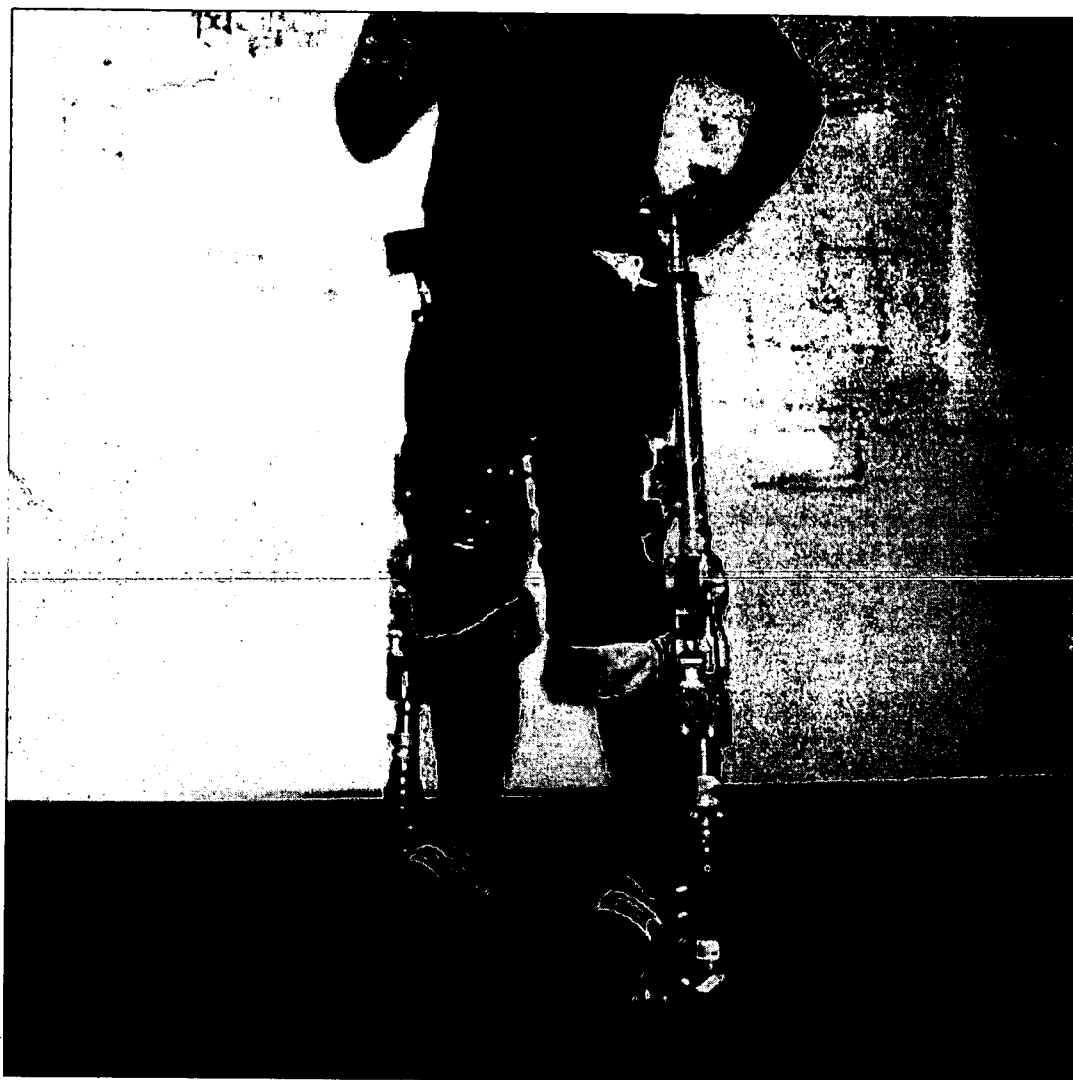

Fig. 24

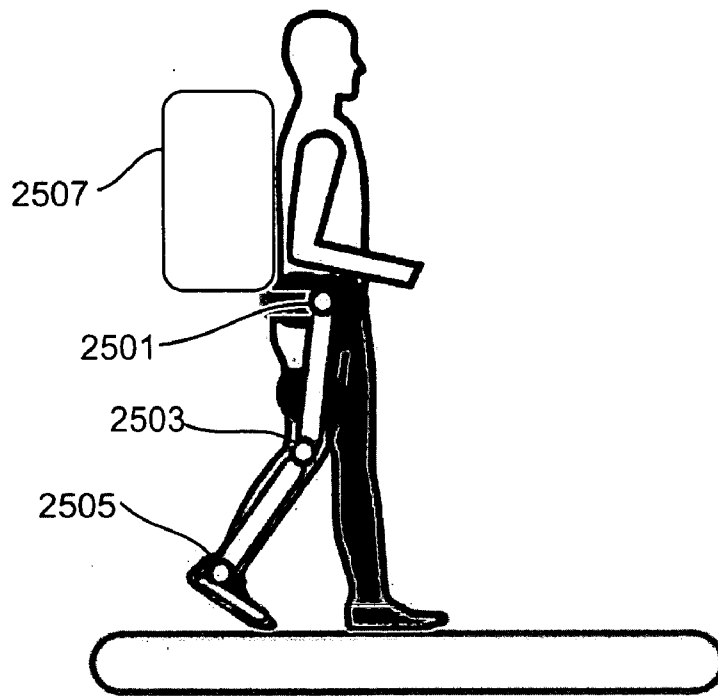

Fig. 25

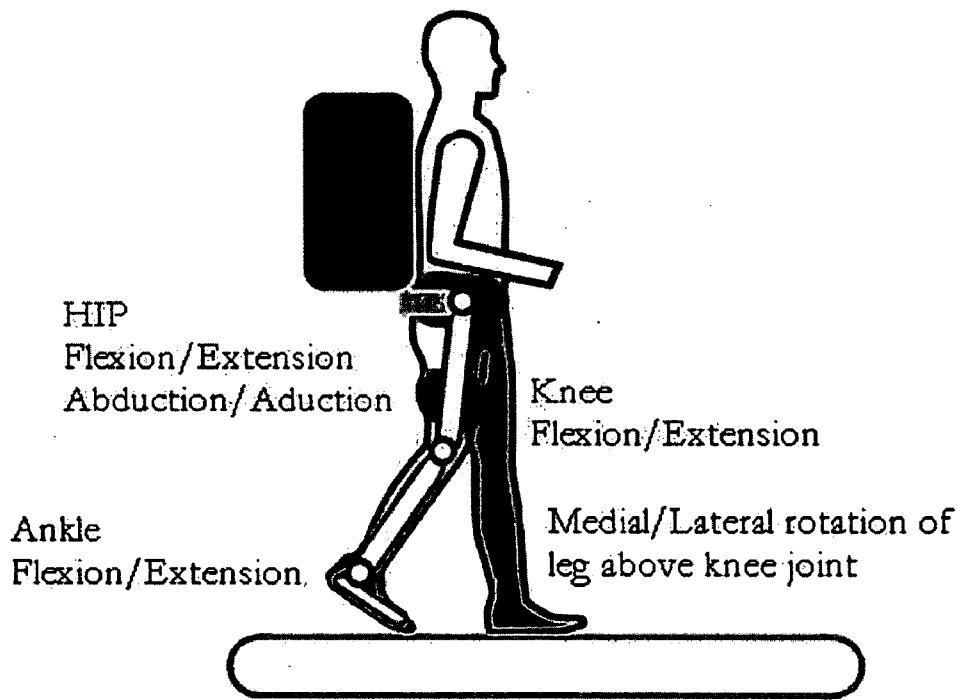
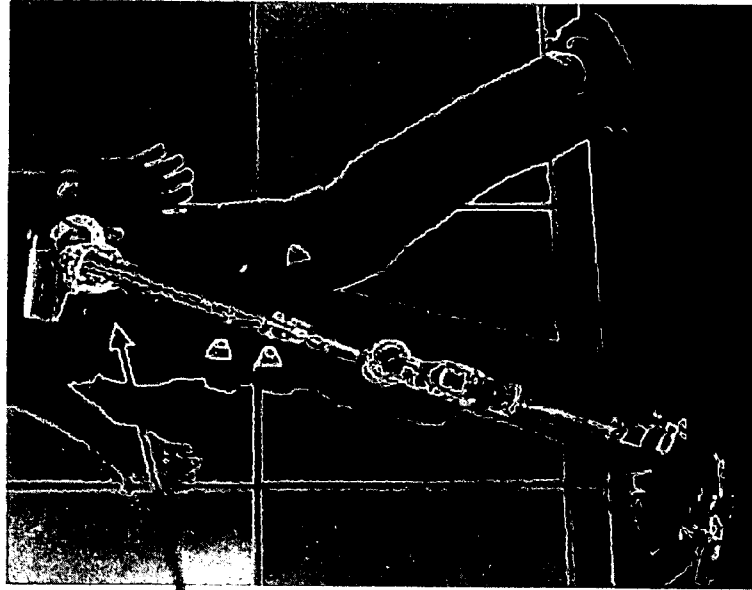

Fig. 26





Revolute joint and  
Kaydon bearing allowed  
for hip flexion/extension

Revolute joint and Igus  
bearing allowed for hip  
medial/lateral rotation

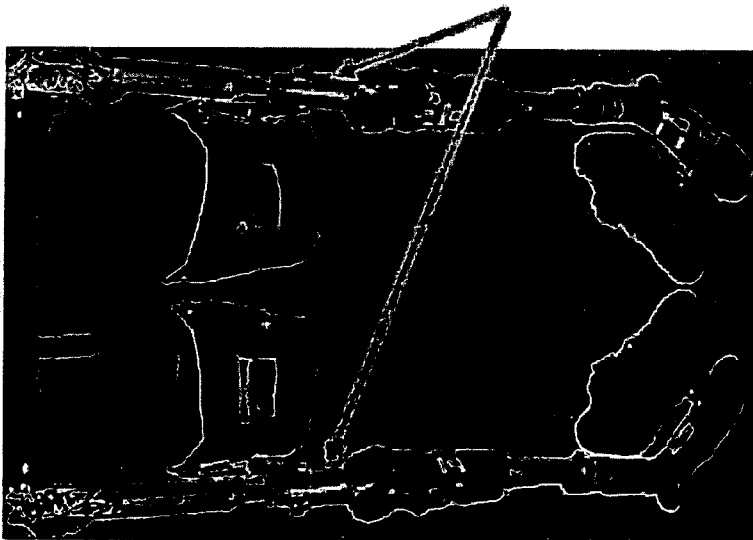

Fig. 27

Fig. 28

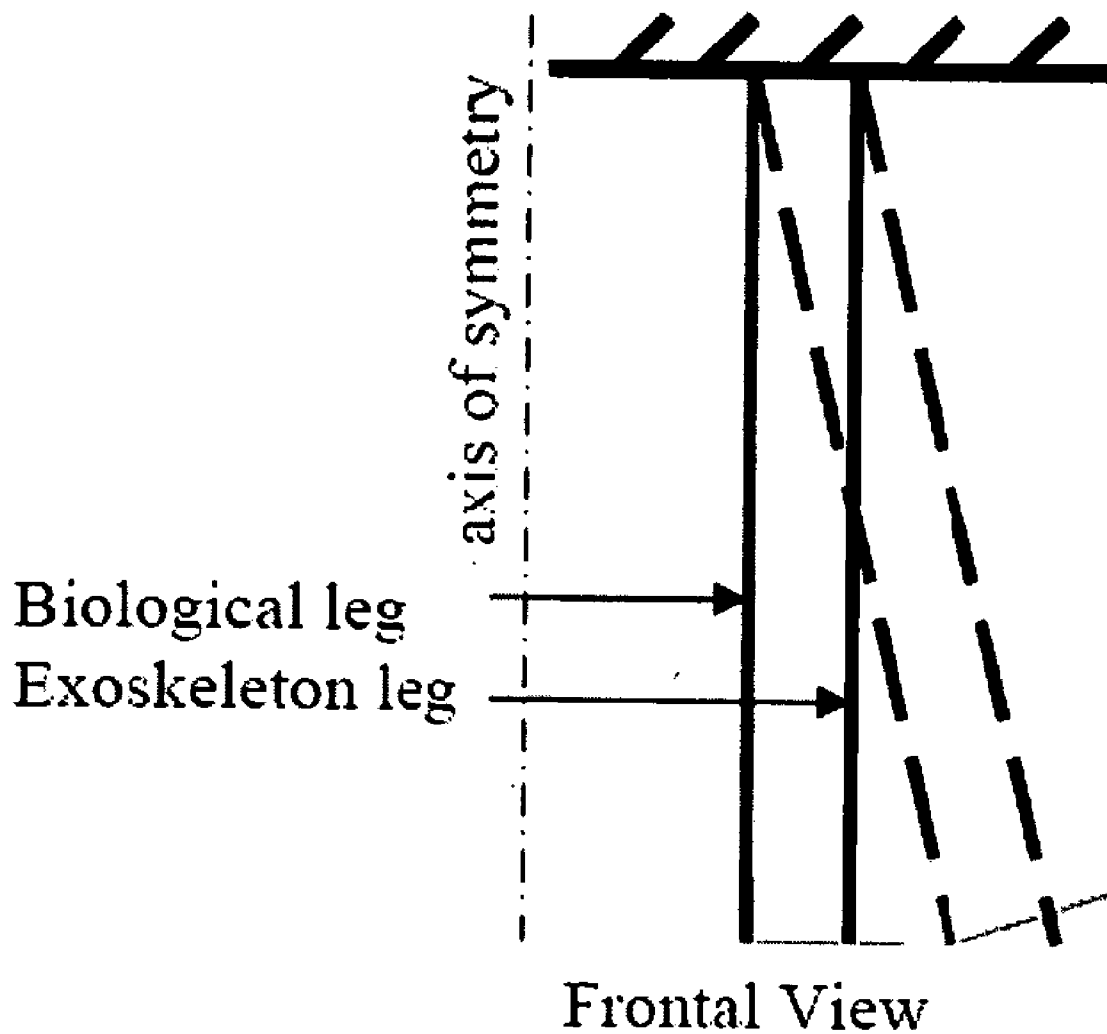

Fig. 29

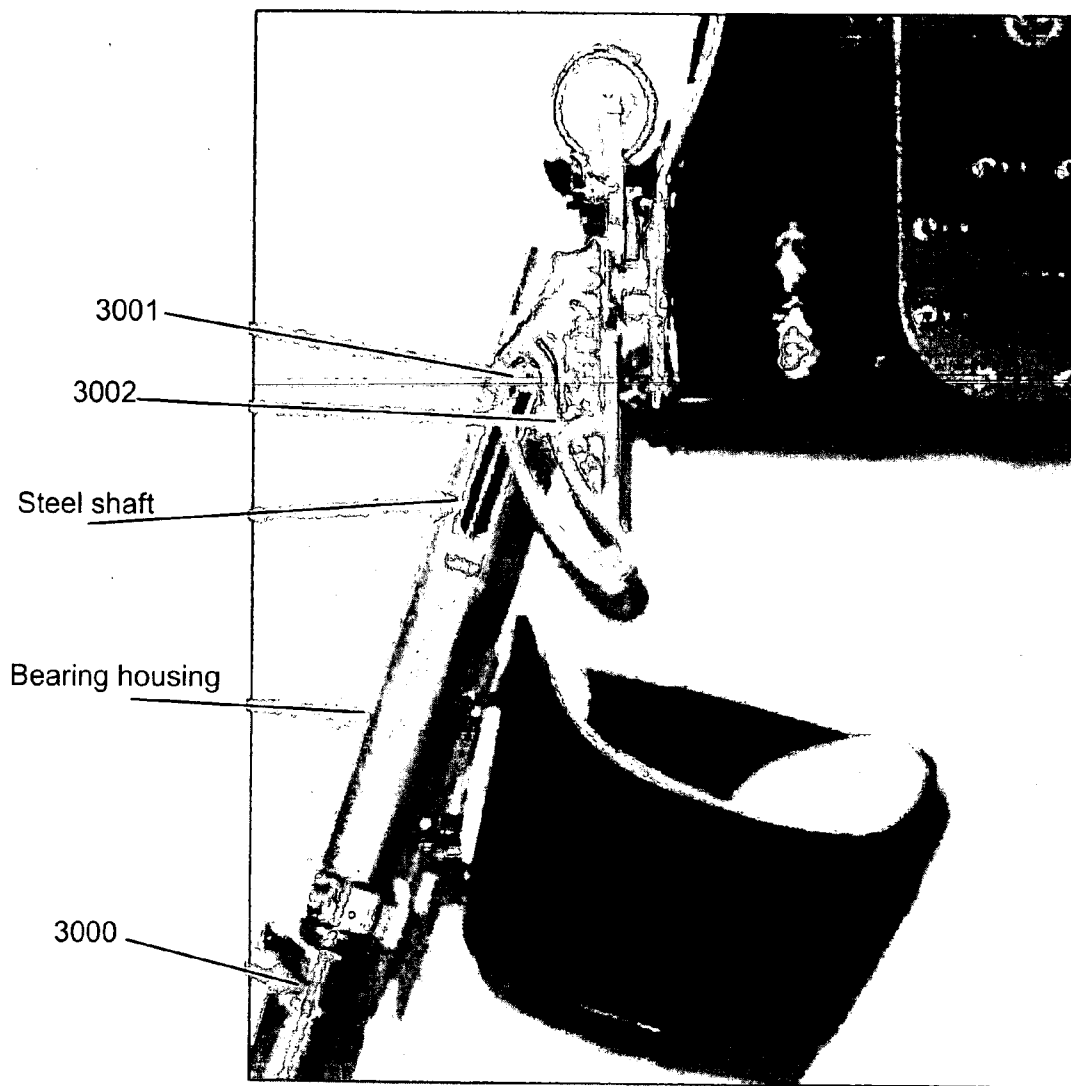

Fig. 30

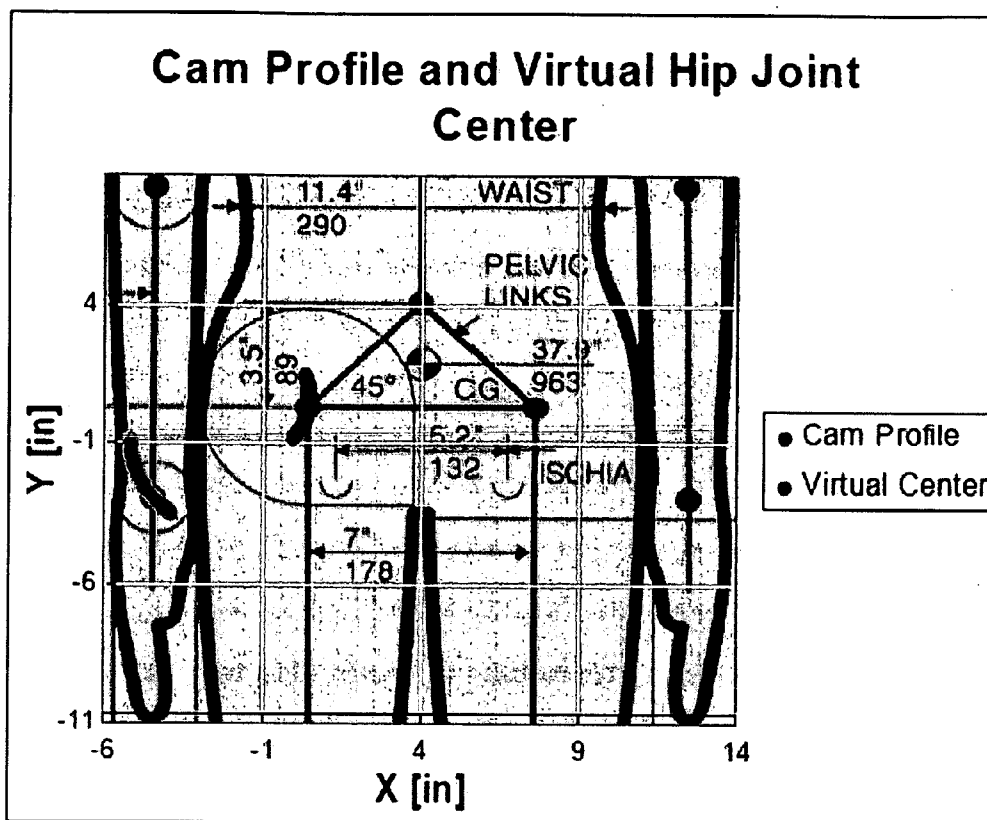

Fig. 31

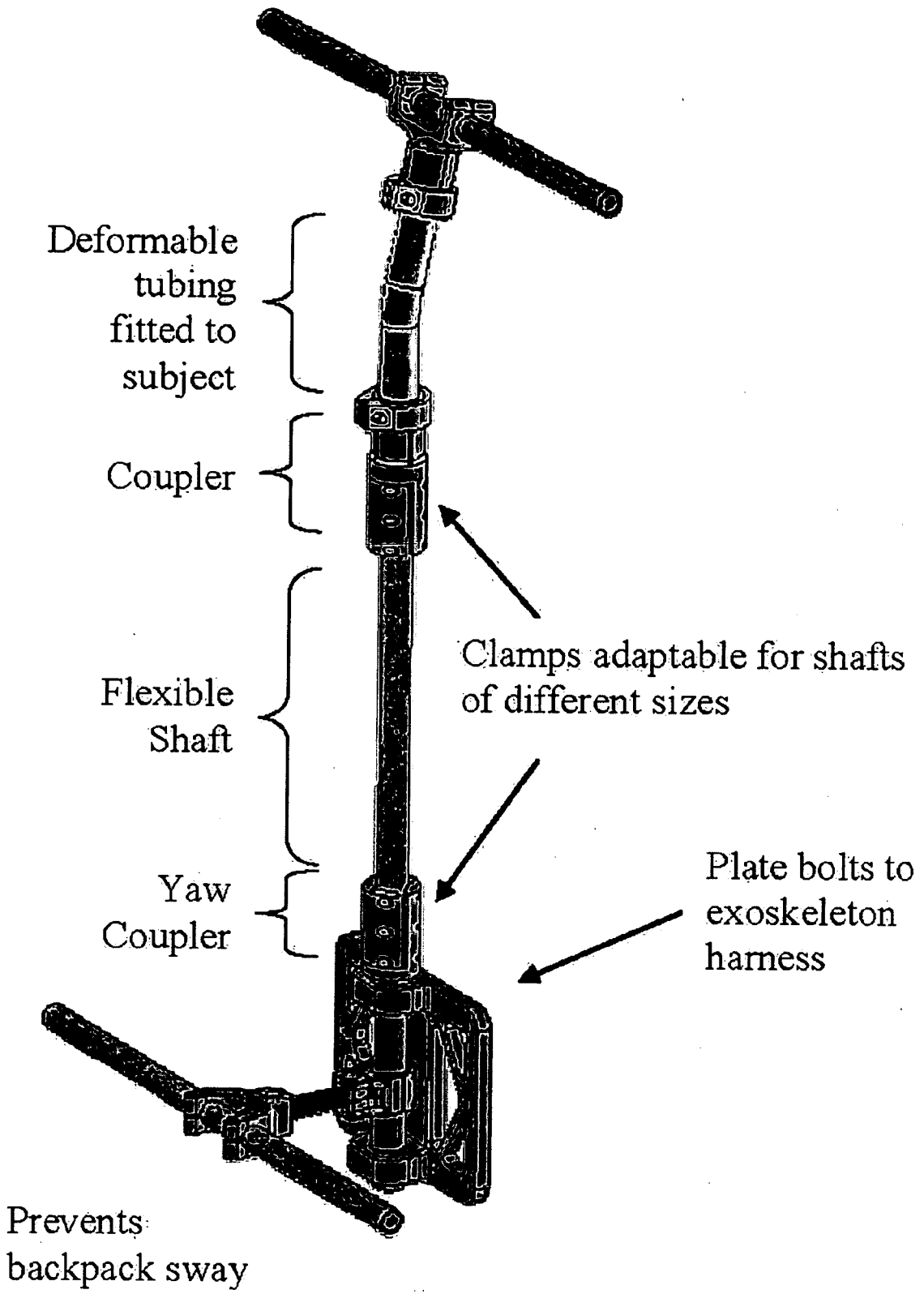

Fig. 32

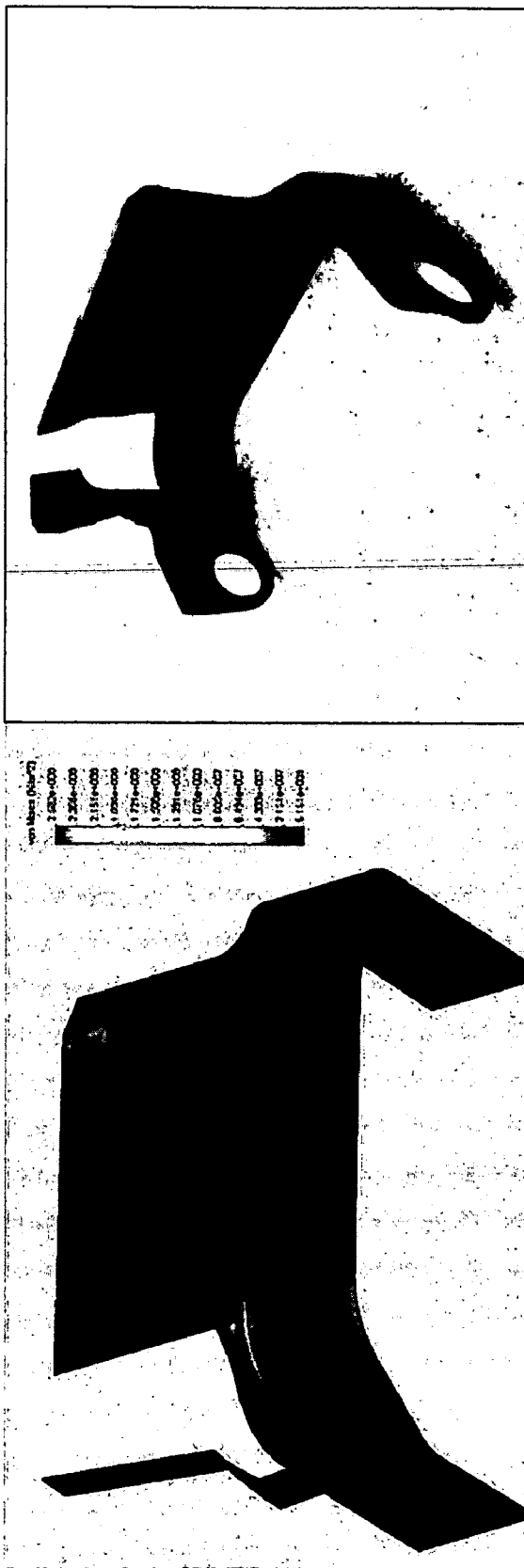

Fig. 34

Fig. 33

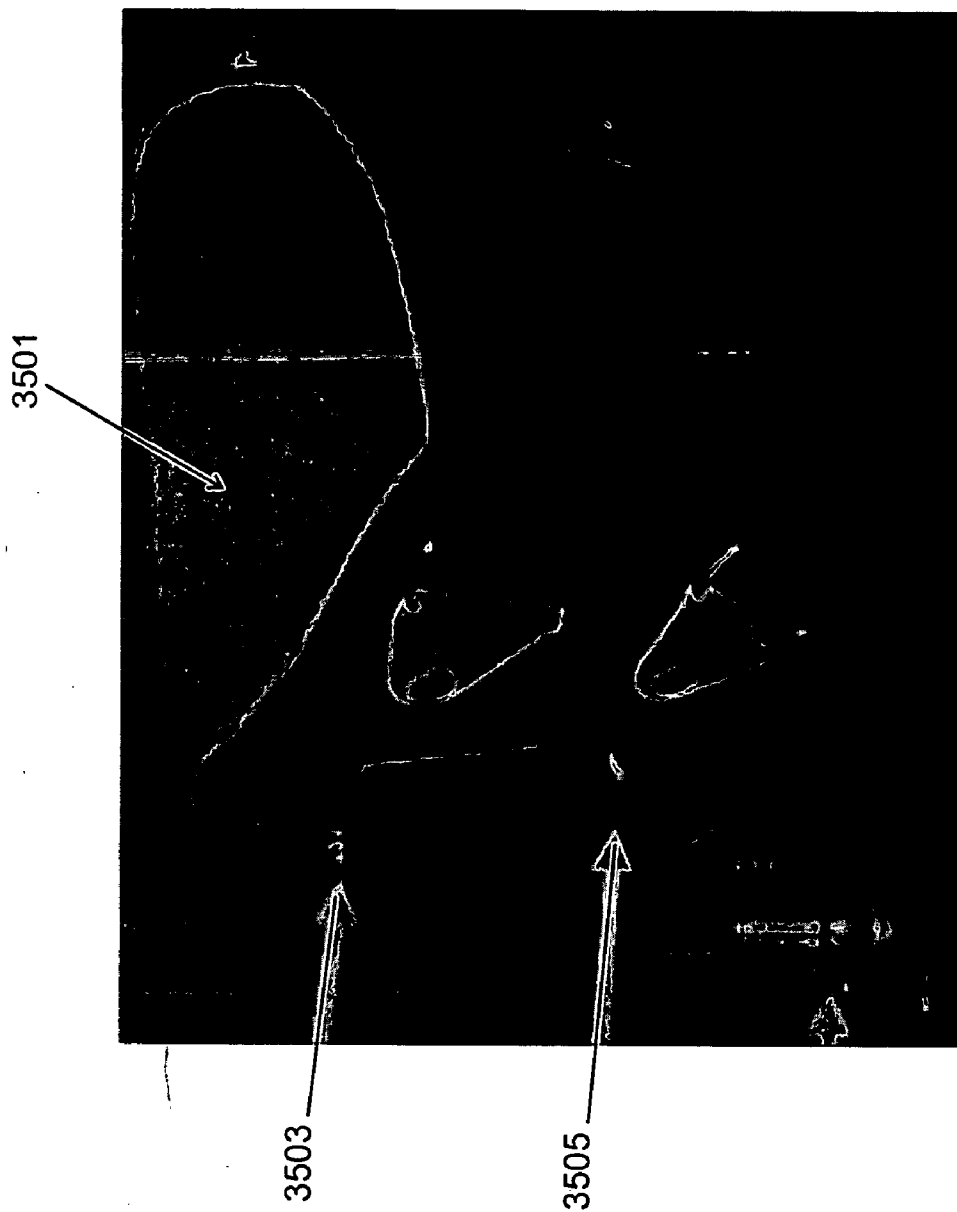

Fig. 35

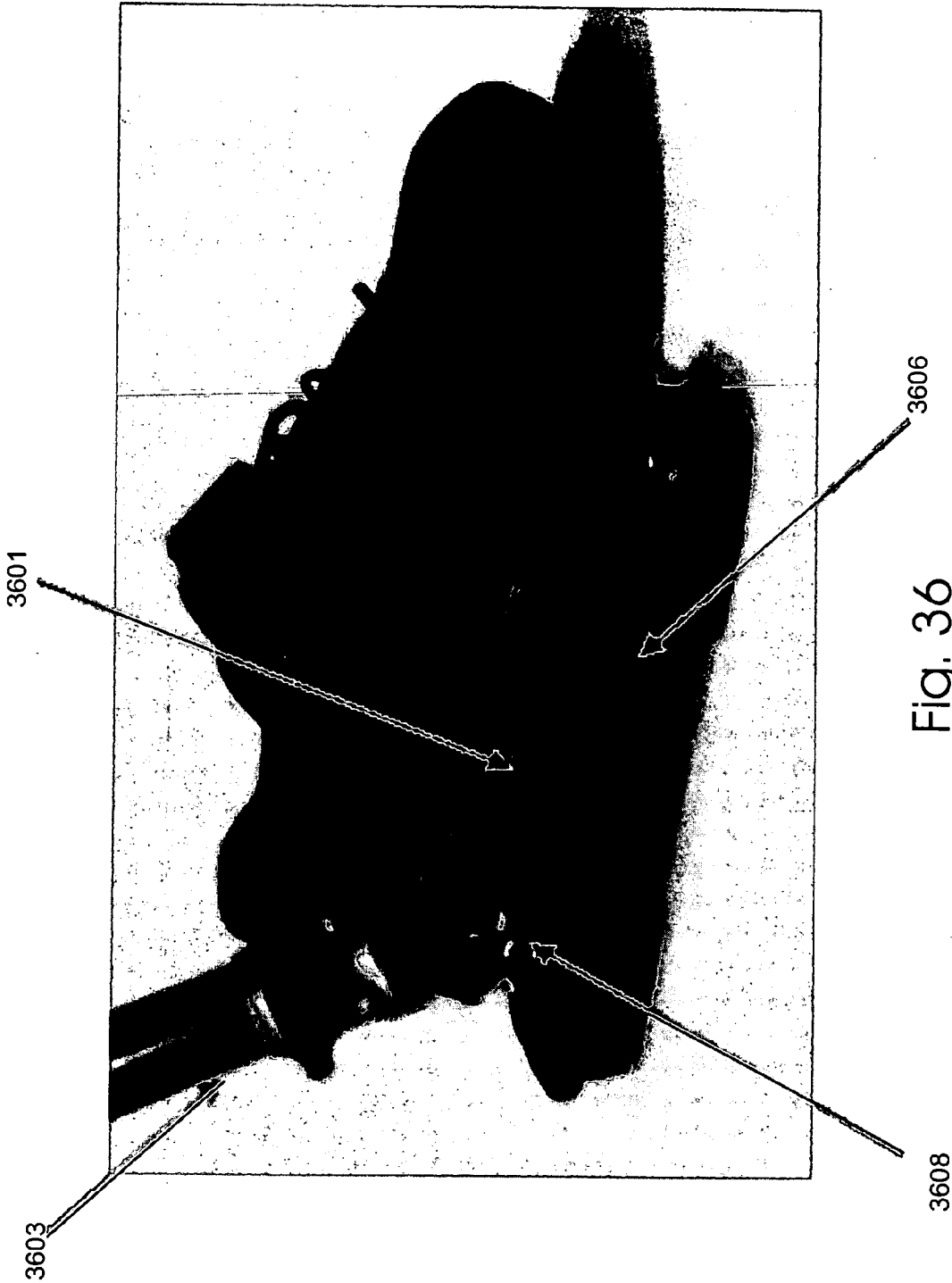

Fig. 36



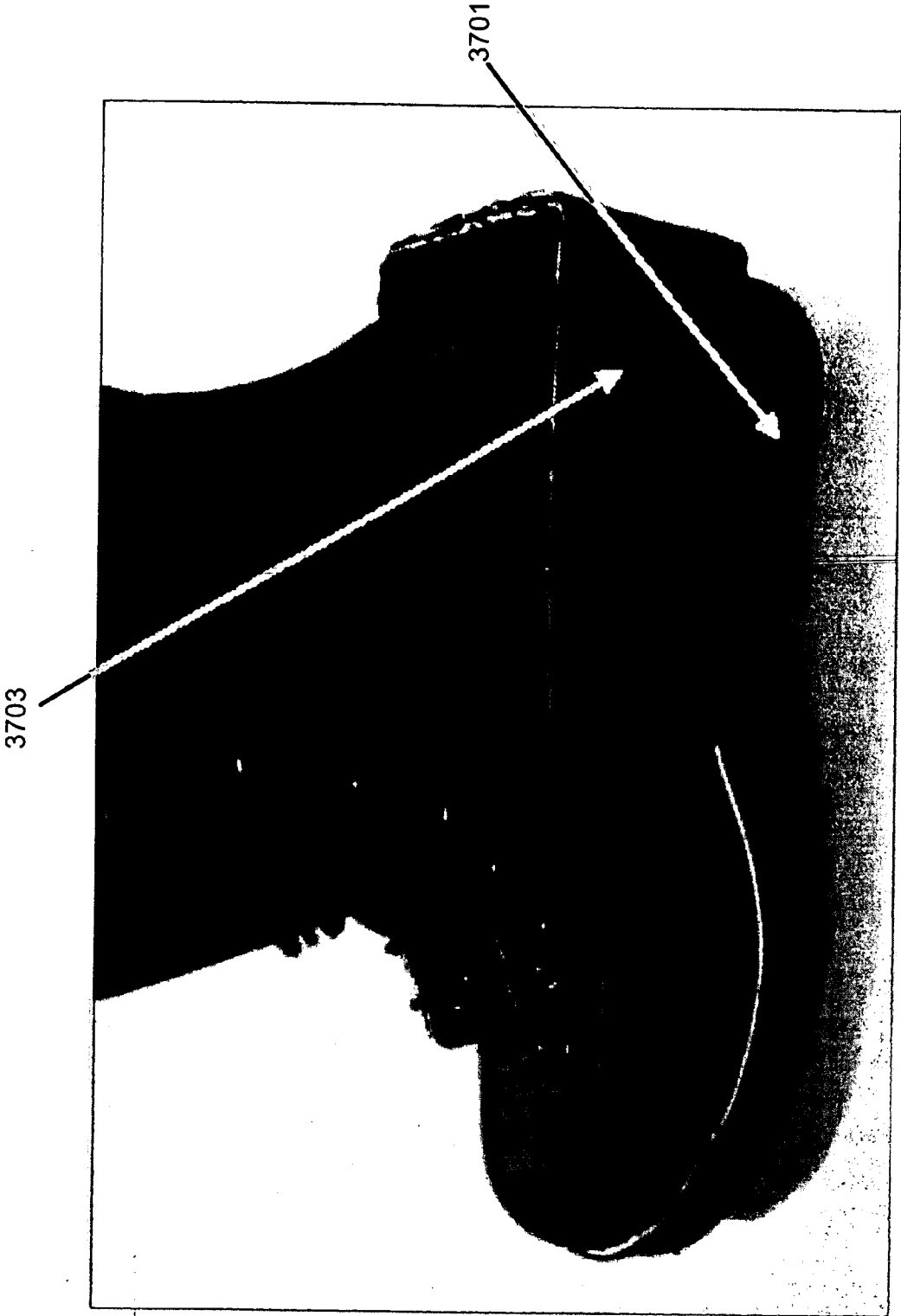

Fig. 37

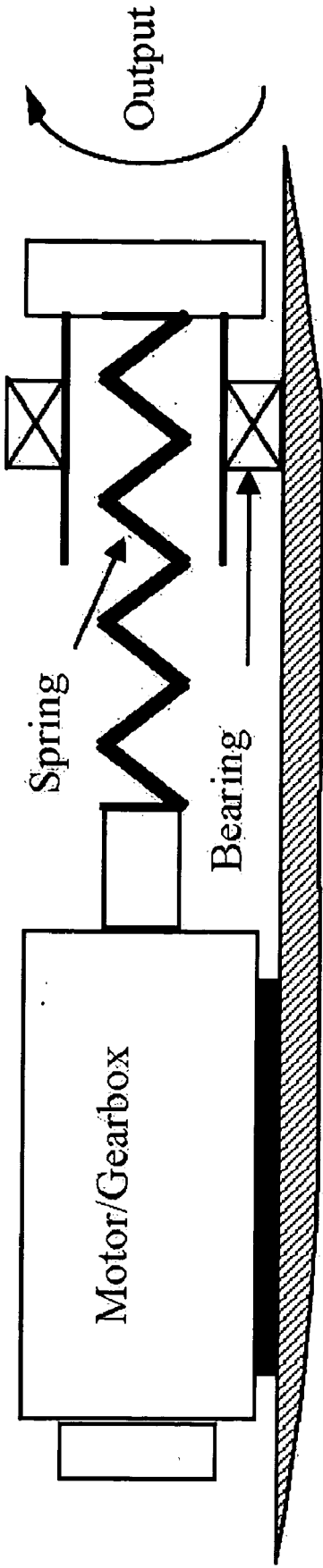

Fig. 38

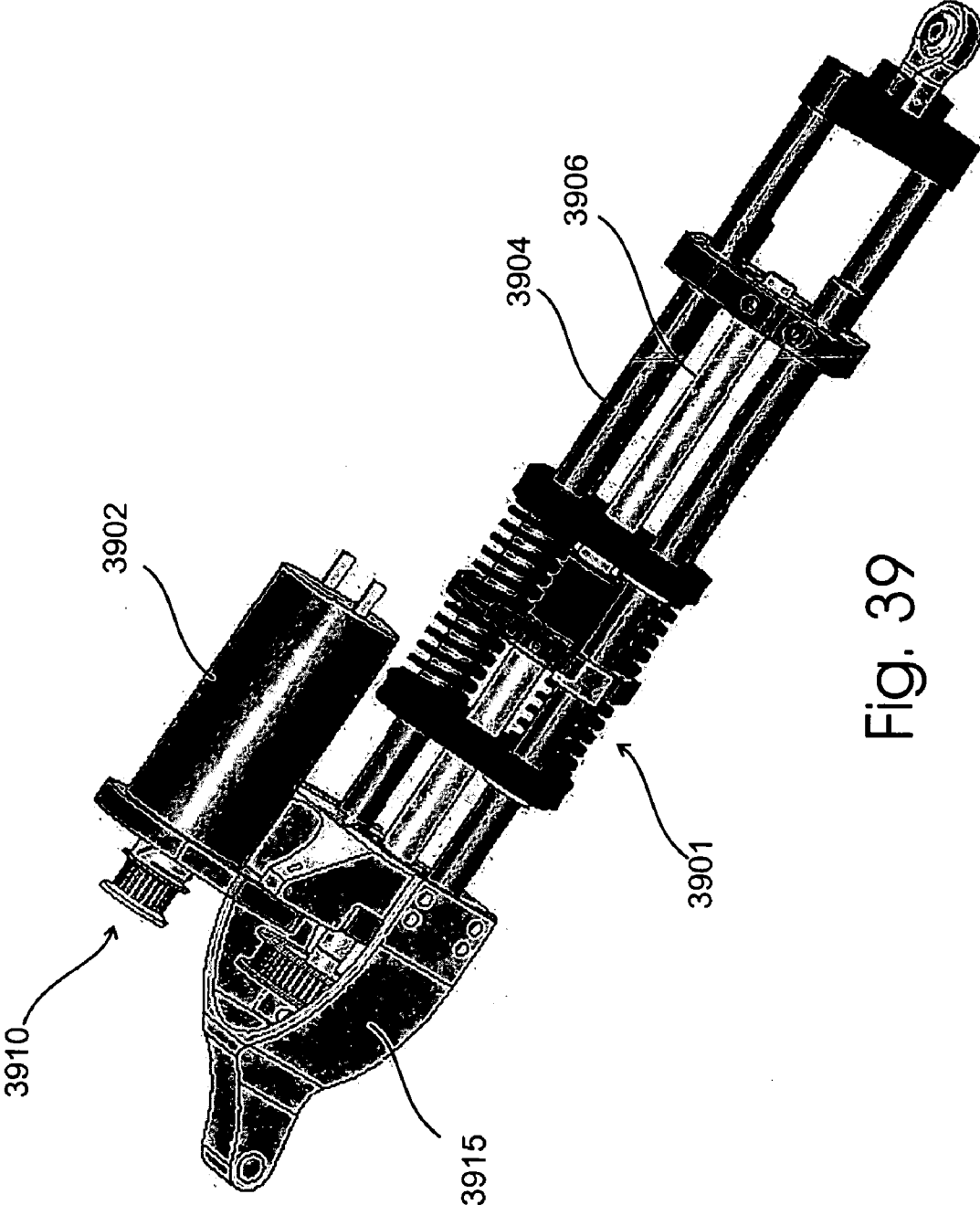

Fig. 39

Closed Loop Bode Diagram showing Experimental and Compensated 2nd Order Model for Fixed End Condition

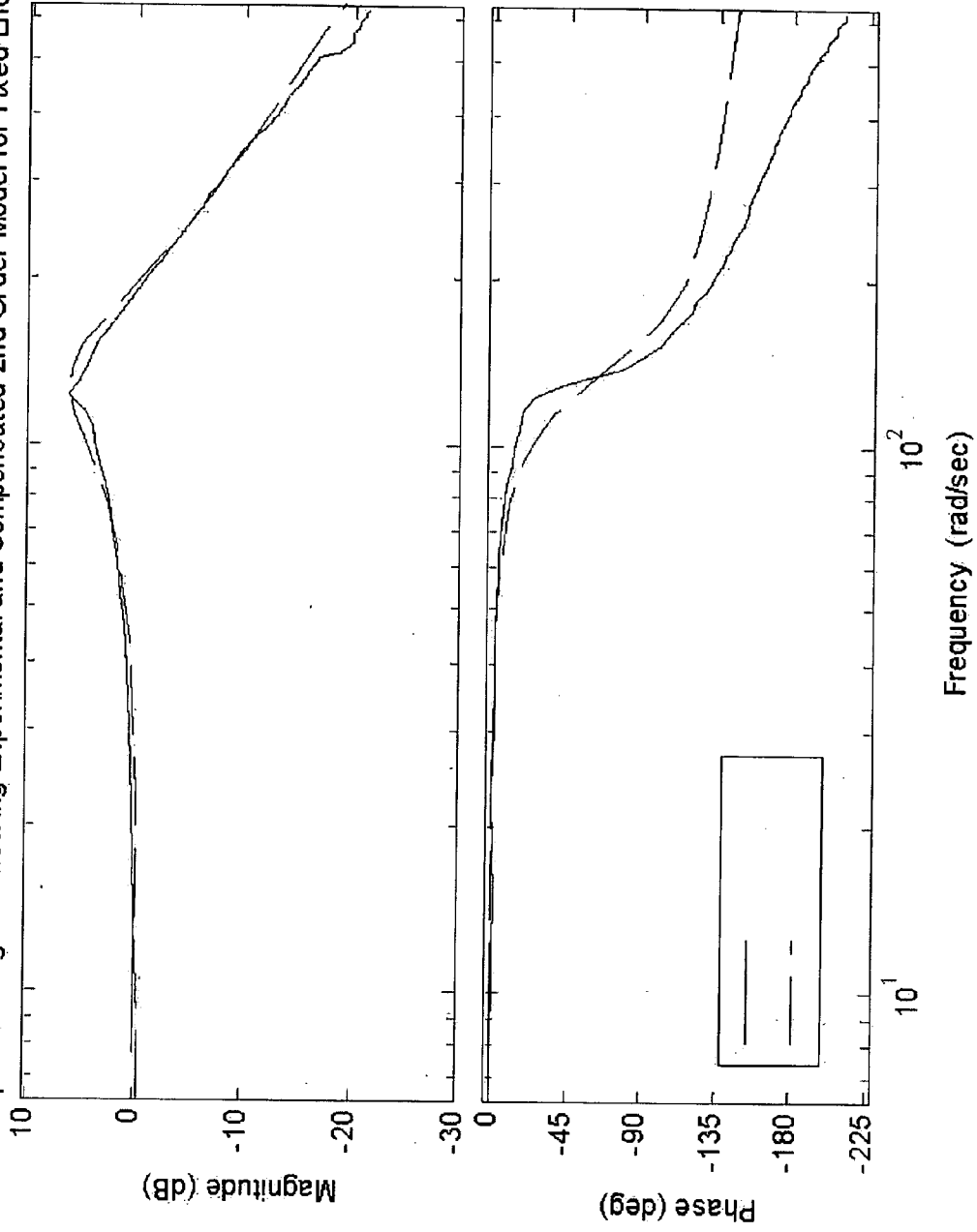

Fig. 40

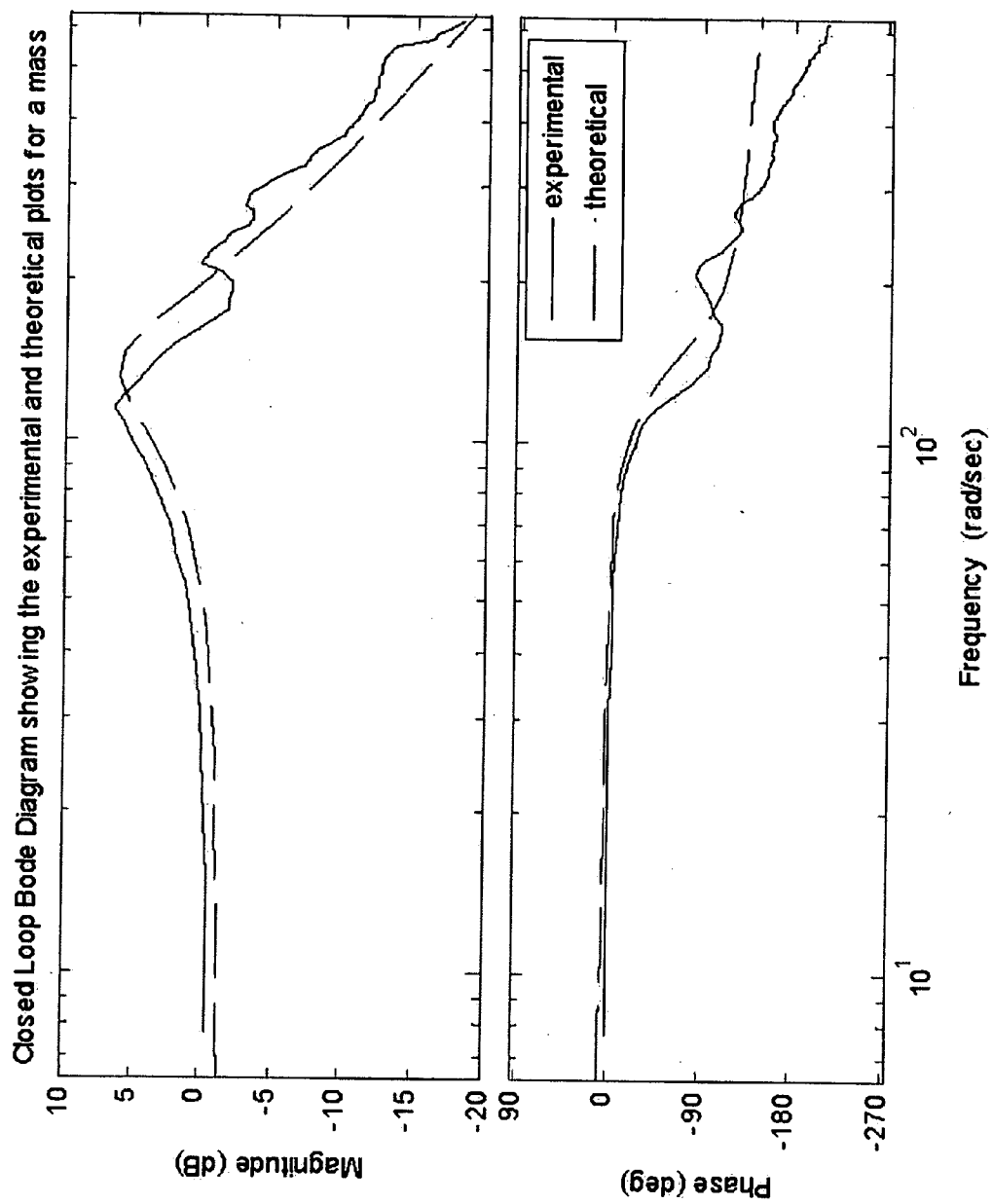

Fig. 41

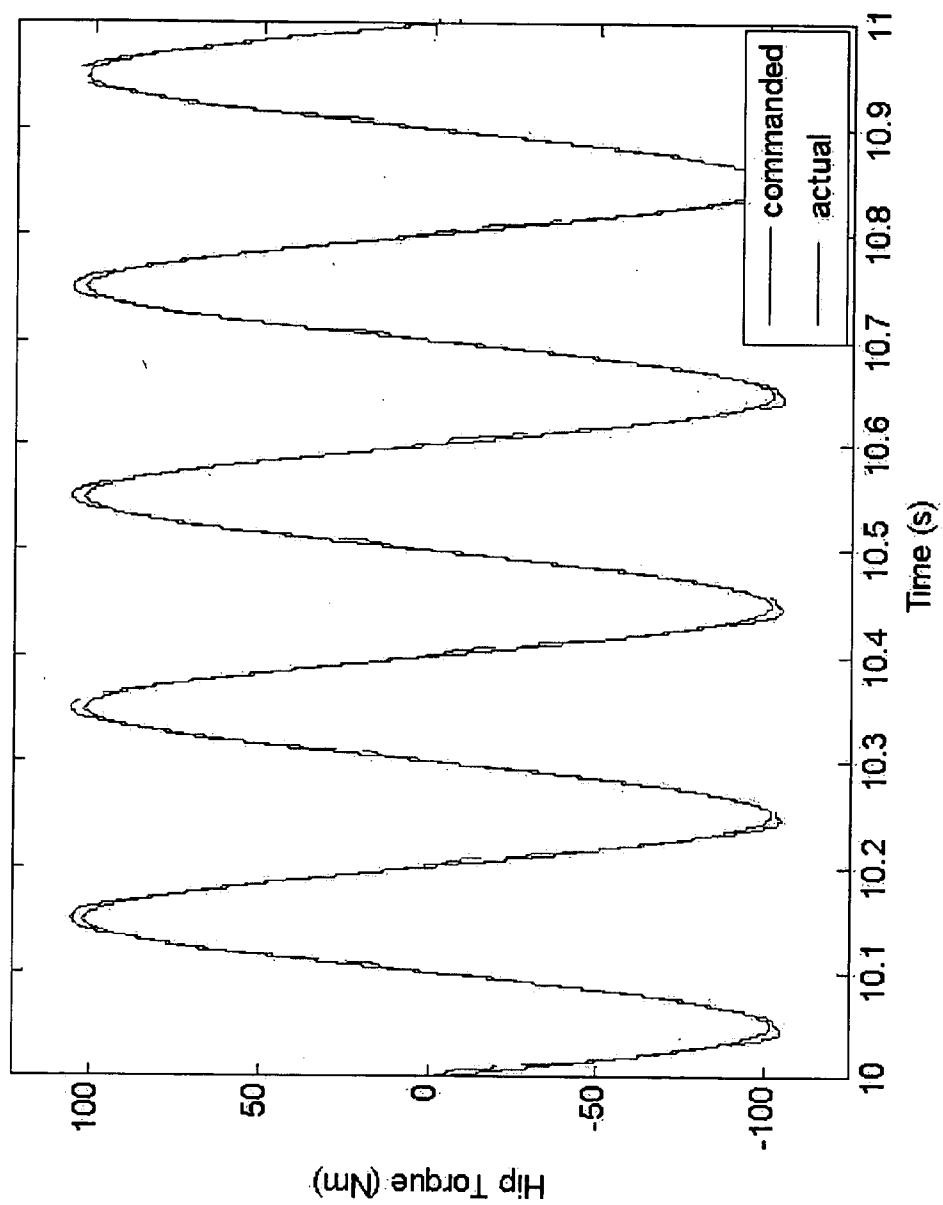

Fig. 42A

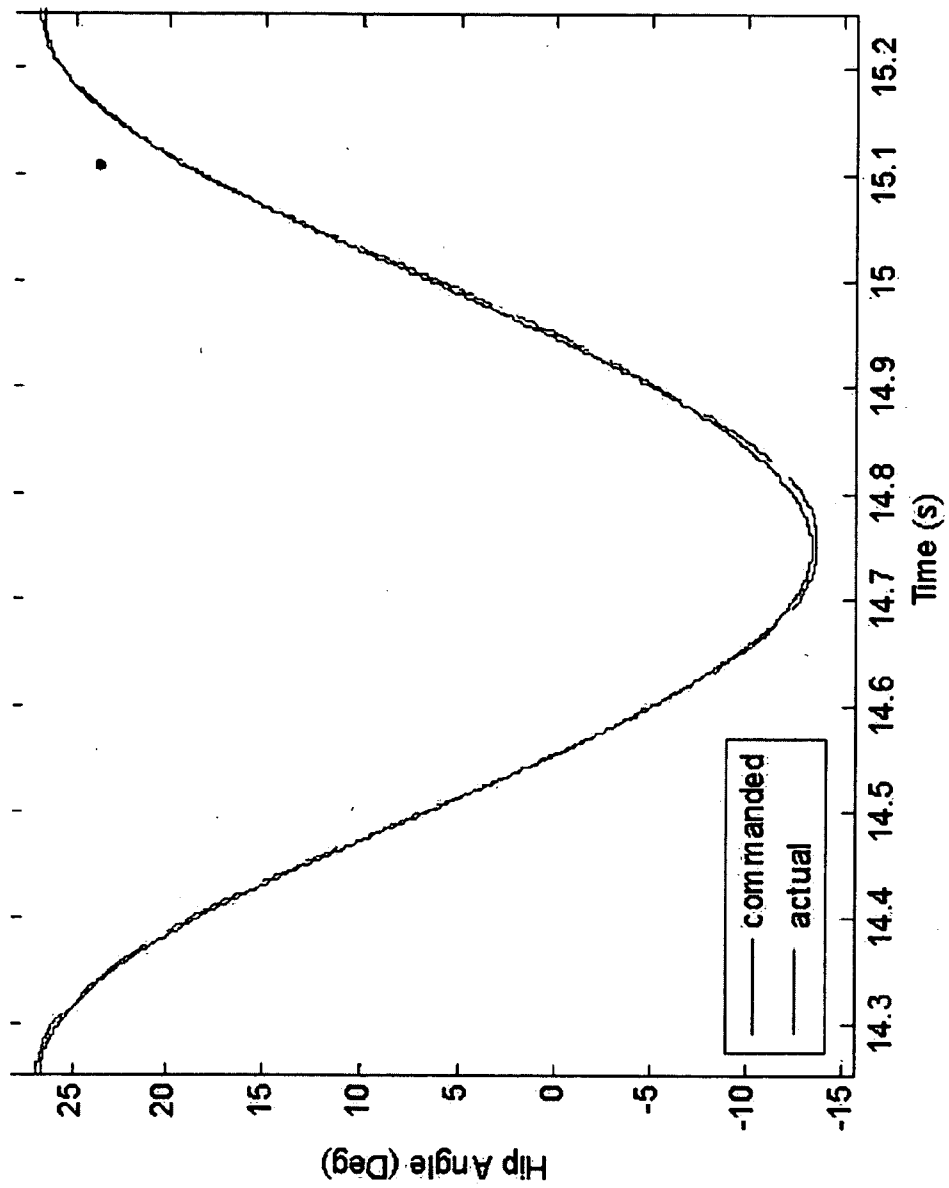

Fig. 42B

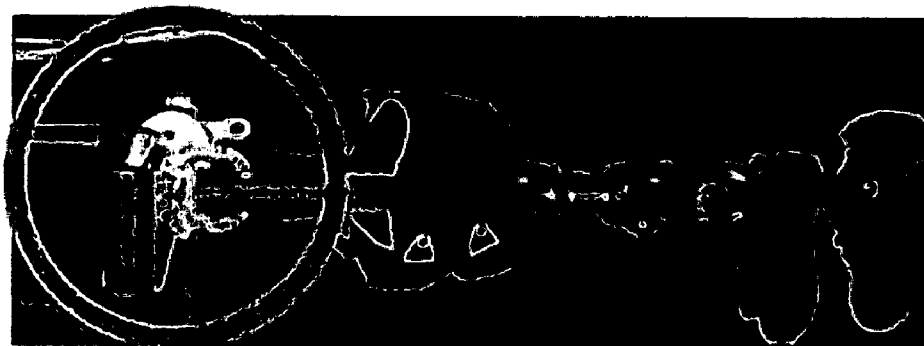

Fig. 44

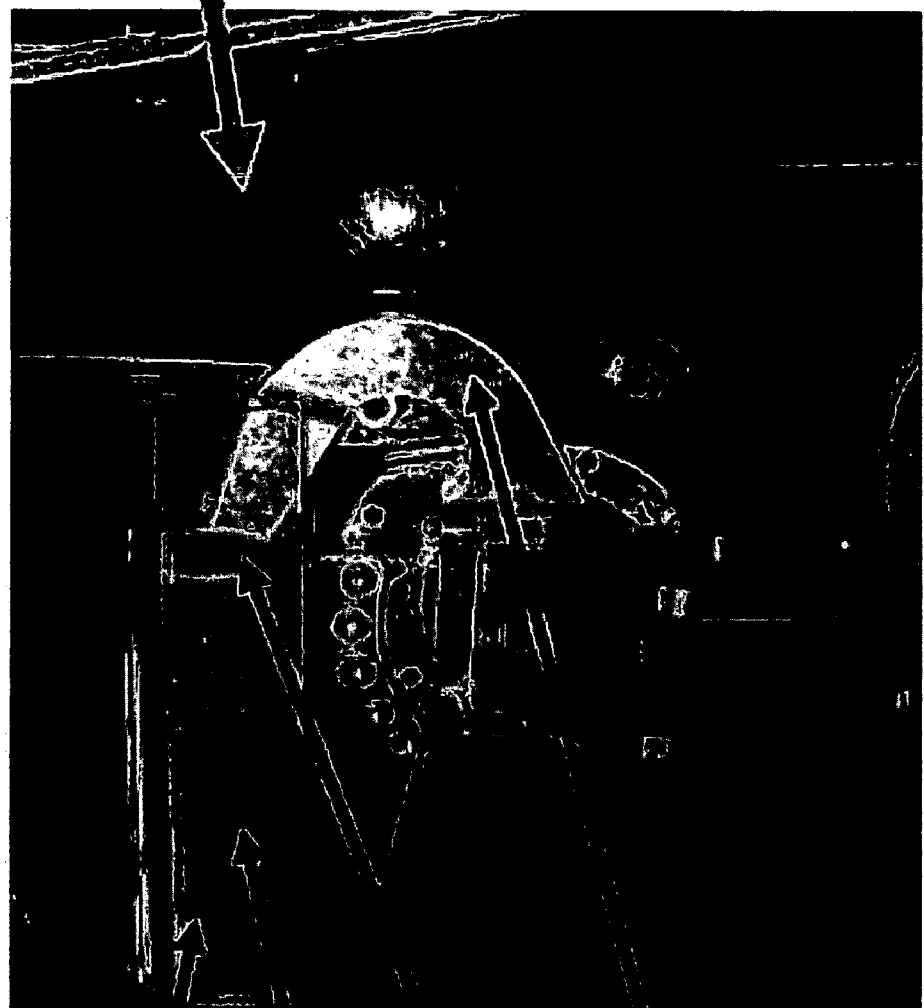

Fig. 43

4301

4301

4308

4306



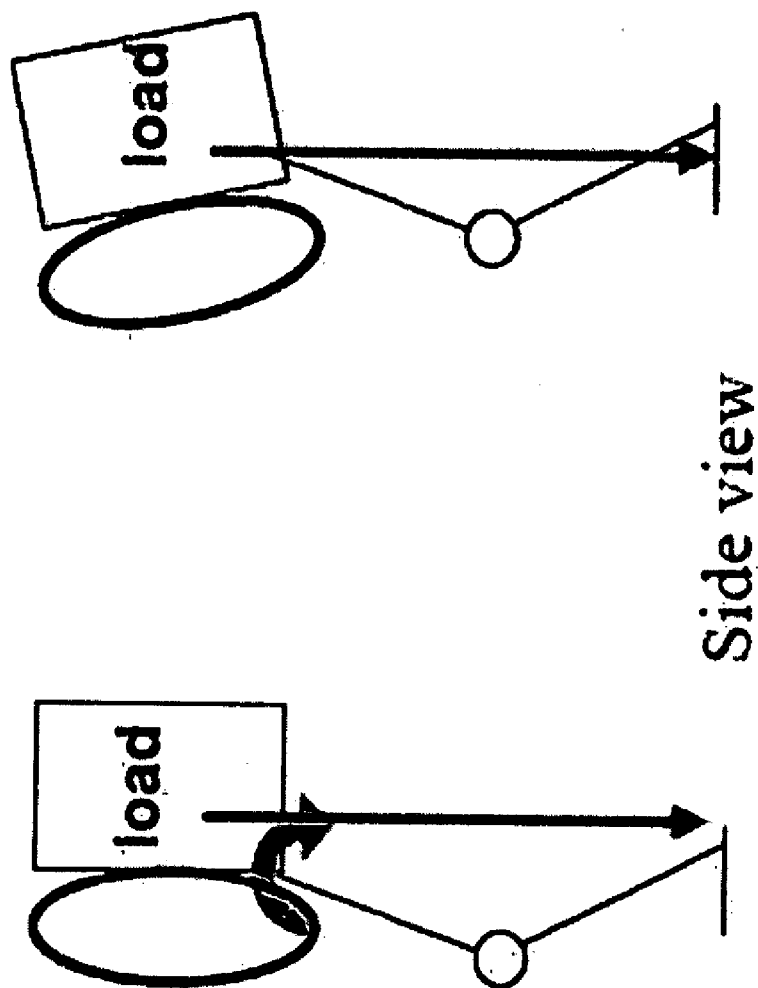

Side view

Fig. 45

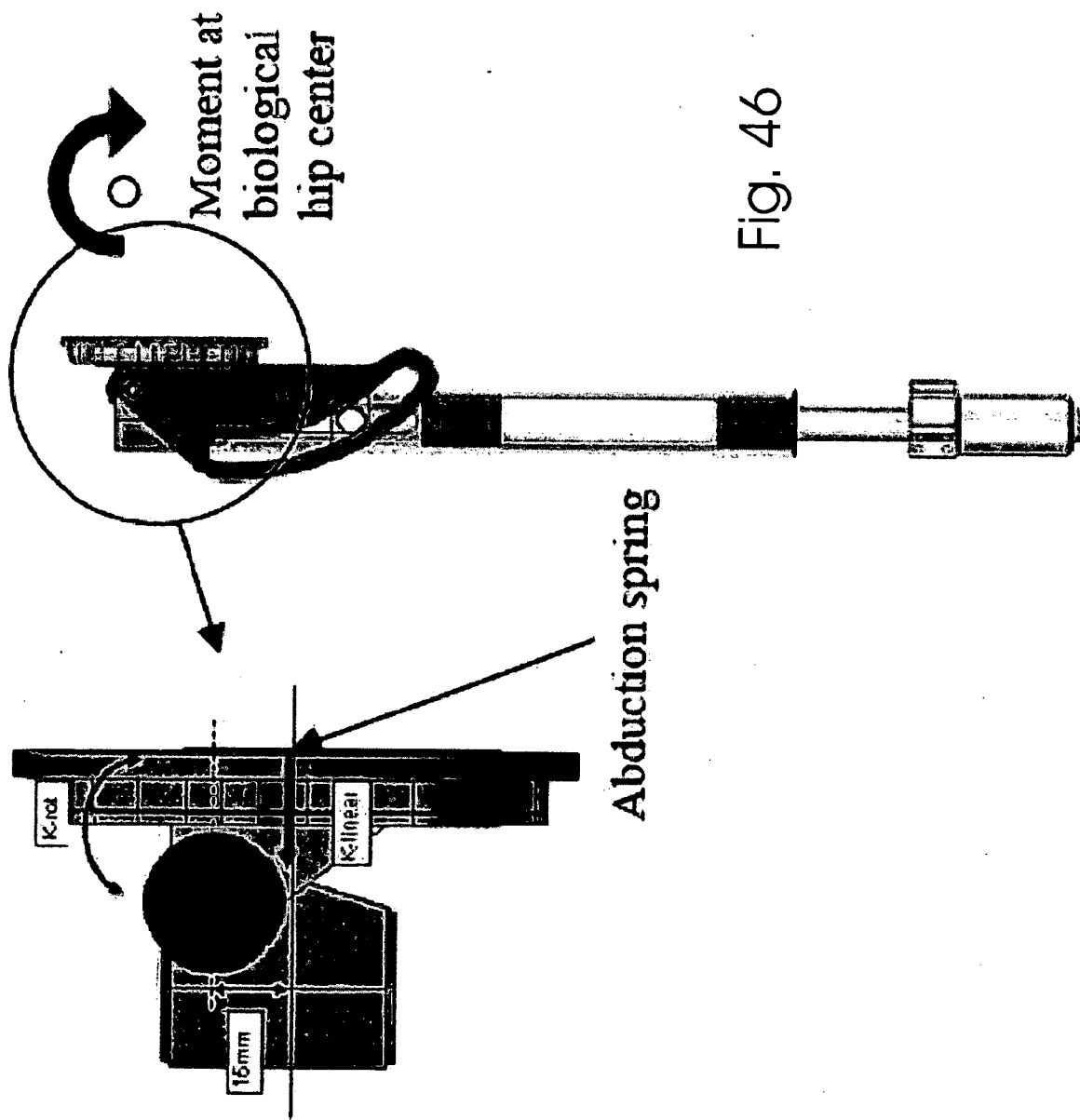

Fig. 46

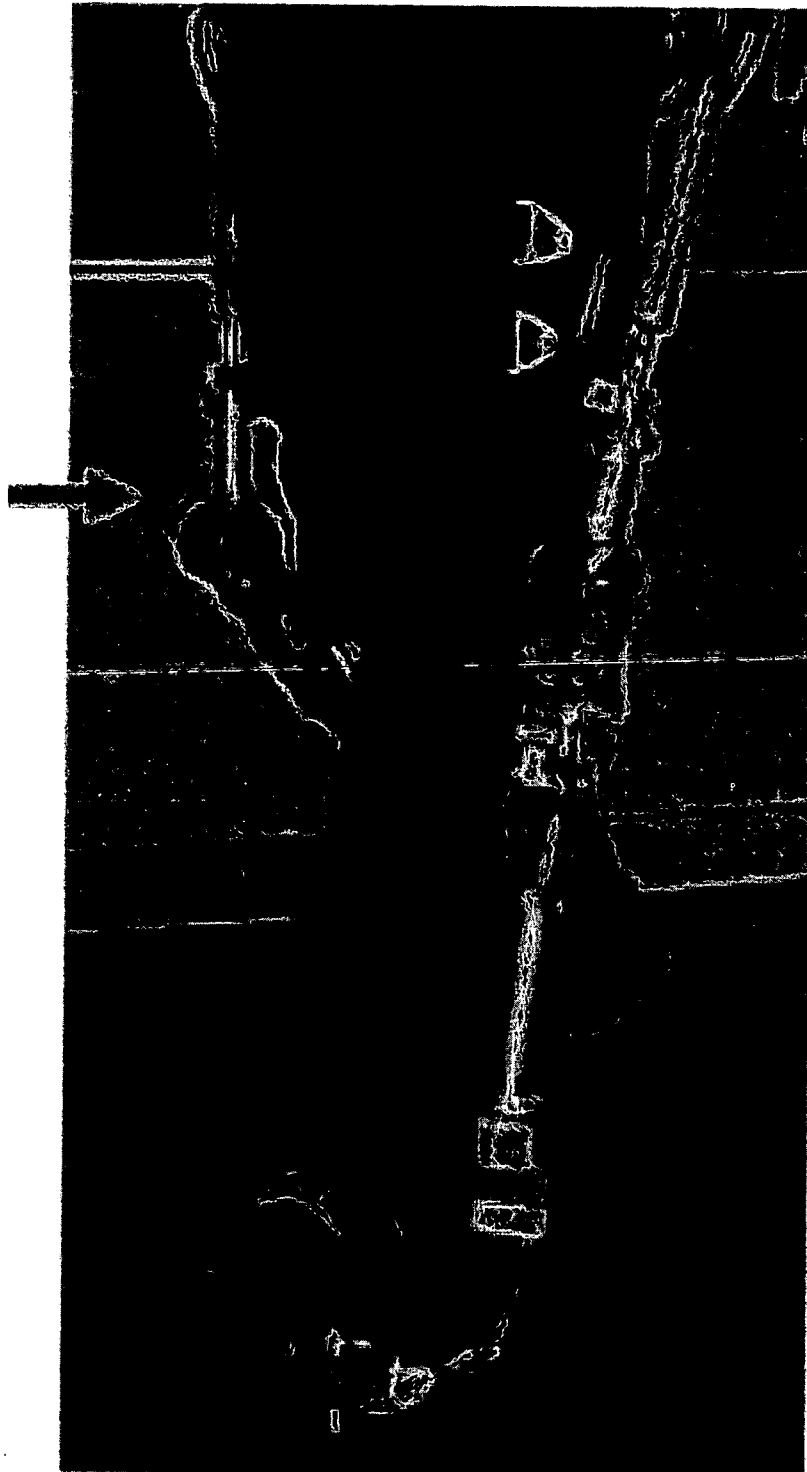

Fig. 47

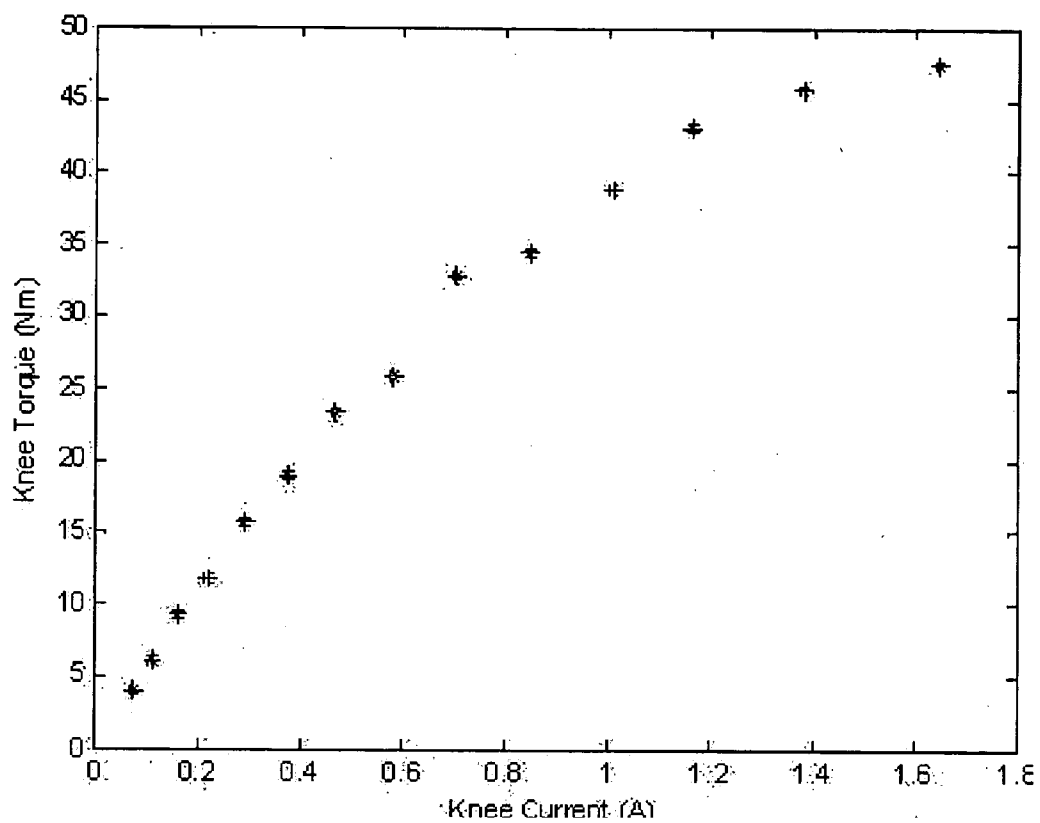

Fig. 48

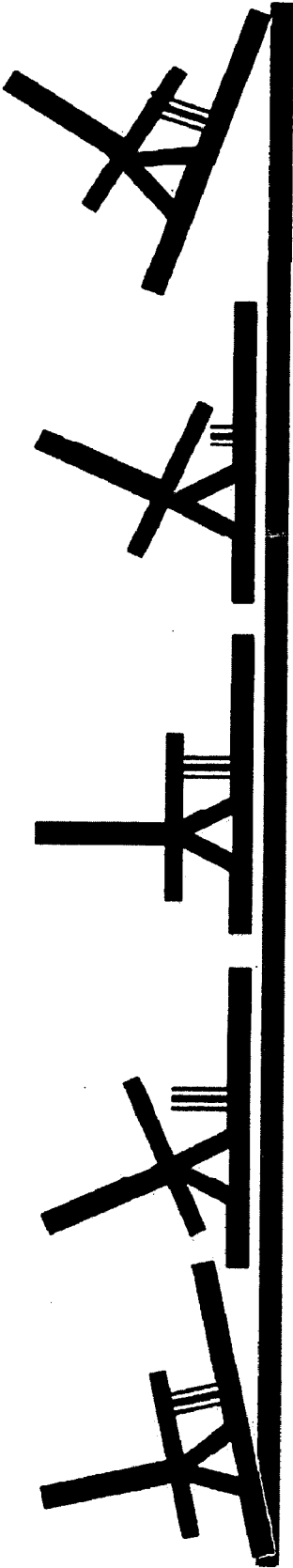

Fig. 49

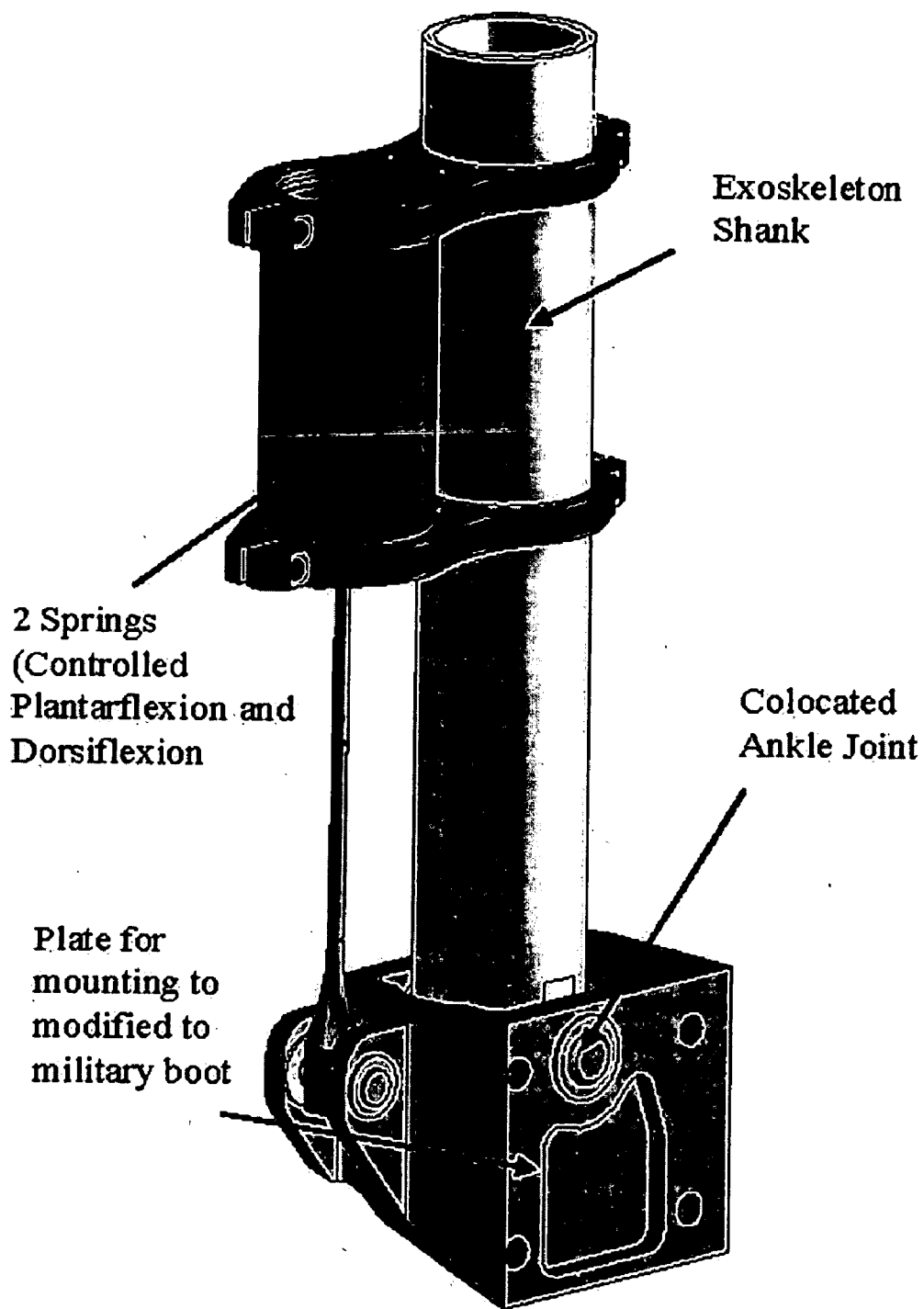

Fig. 50



Fig. 51

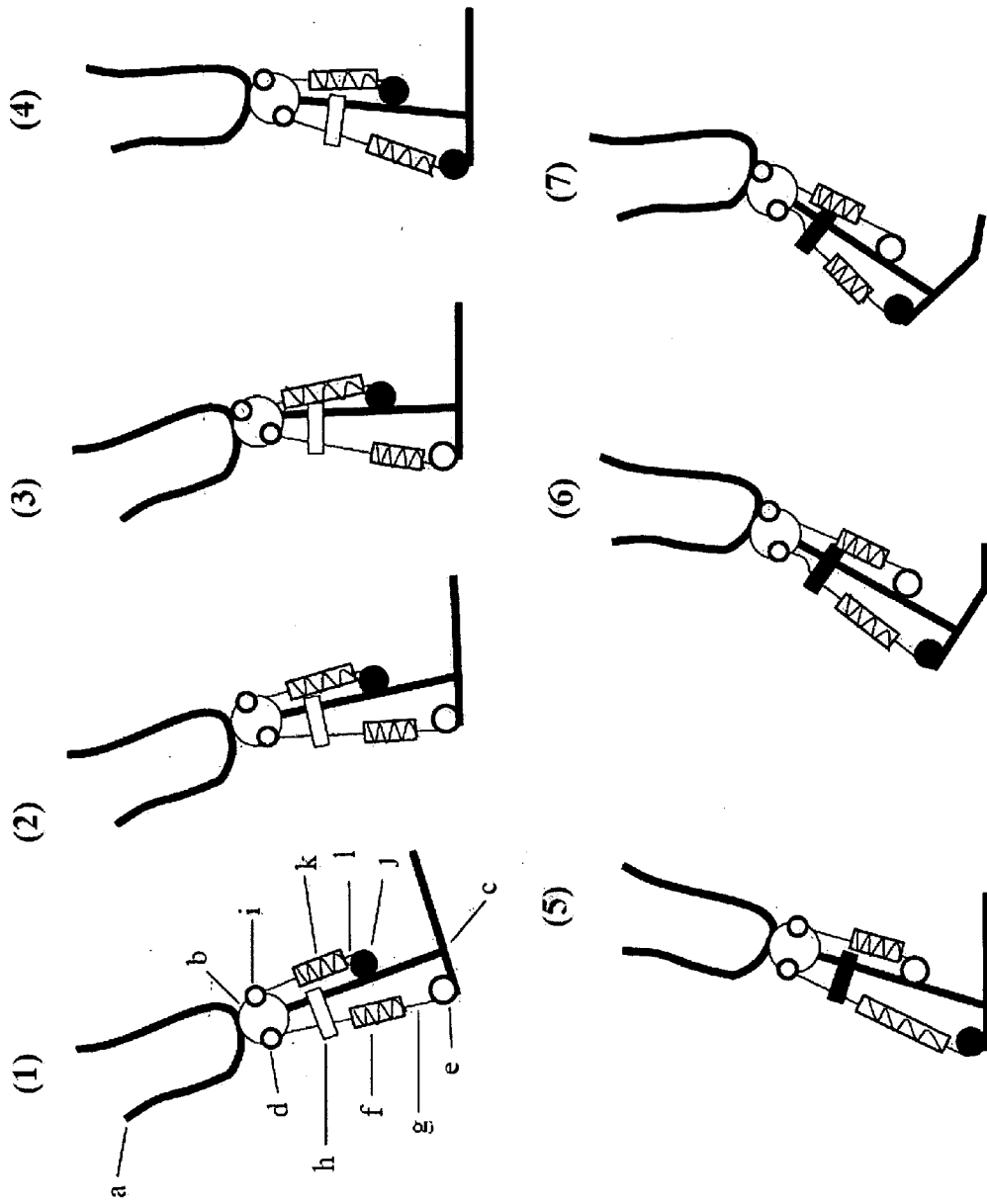
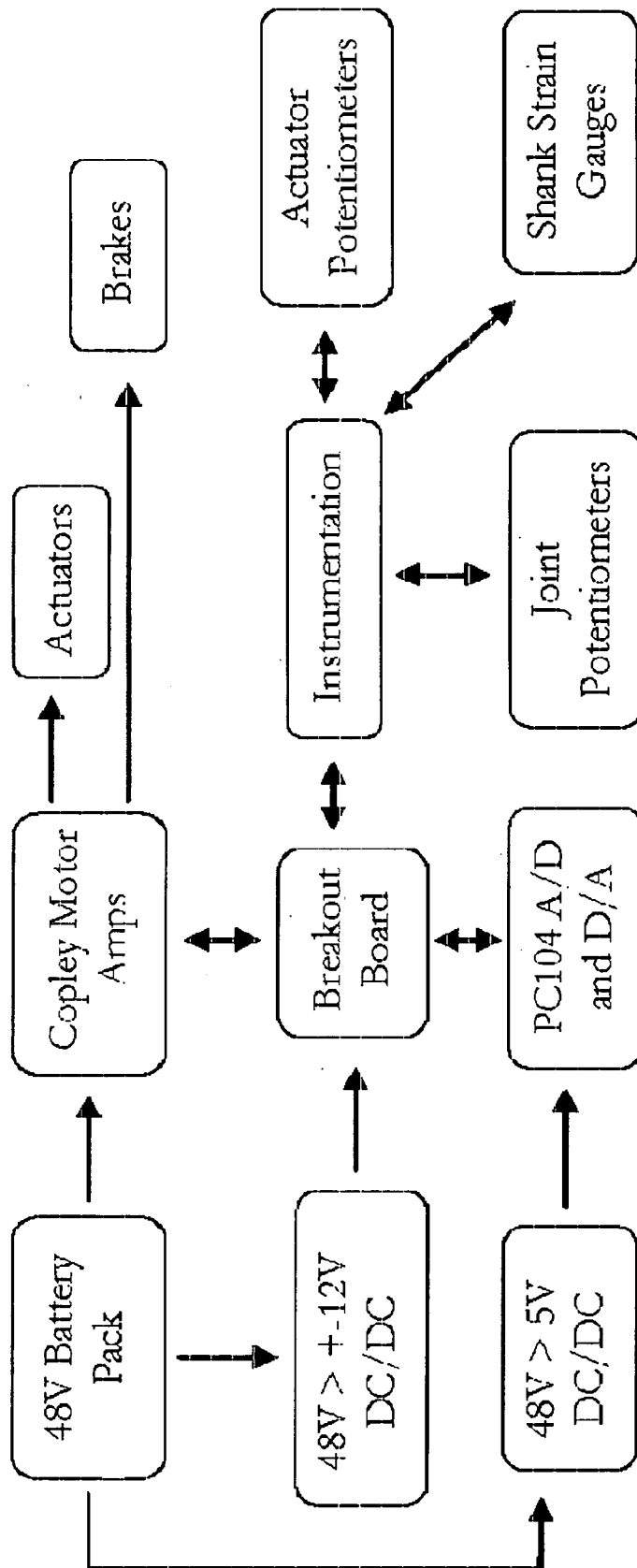

Fig. 52





Fig, 53

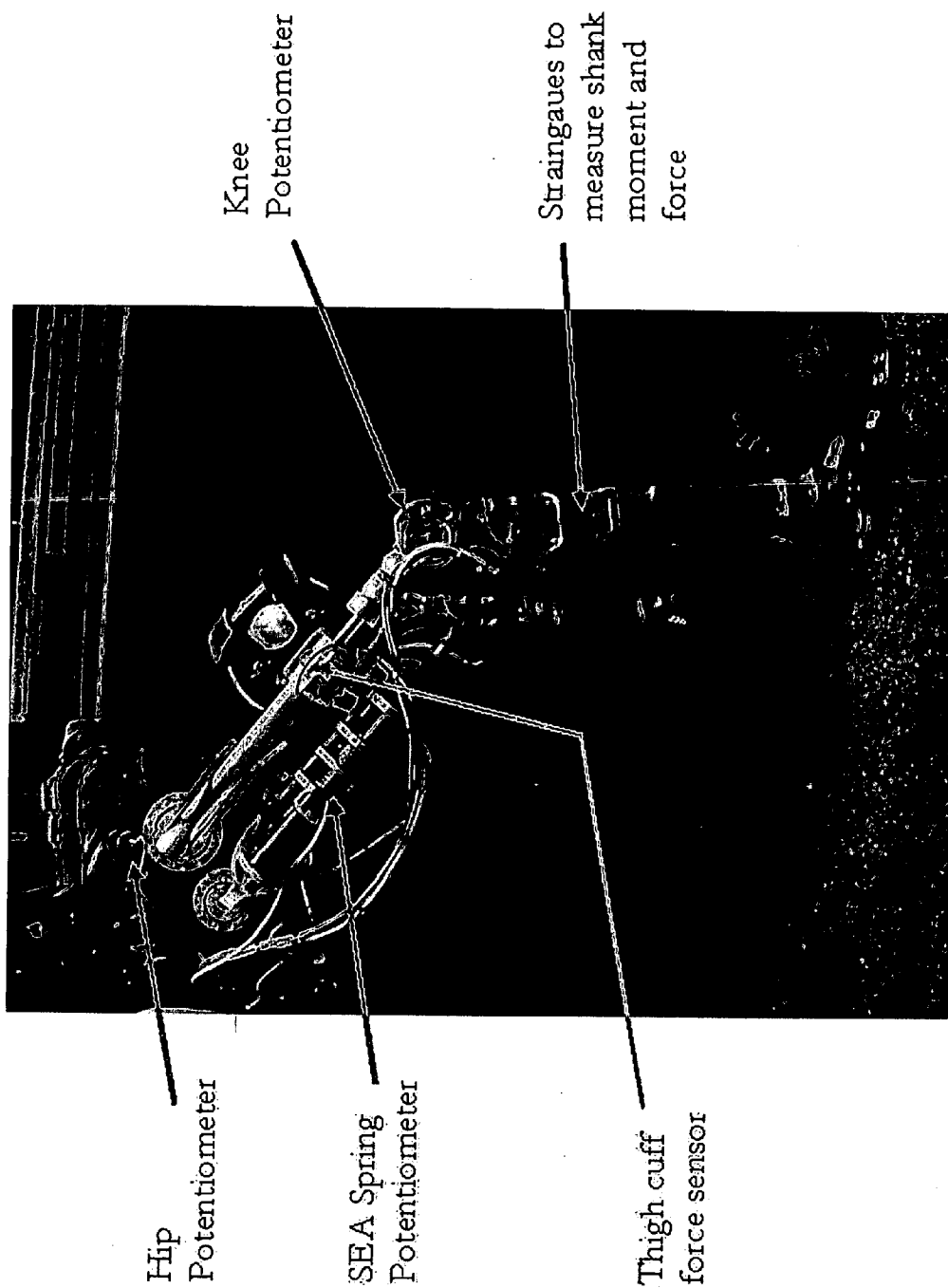

Fig. 54

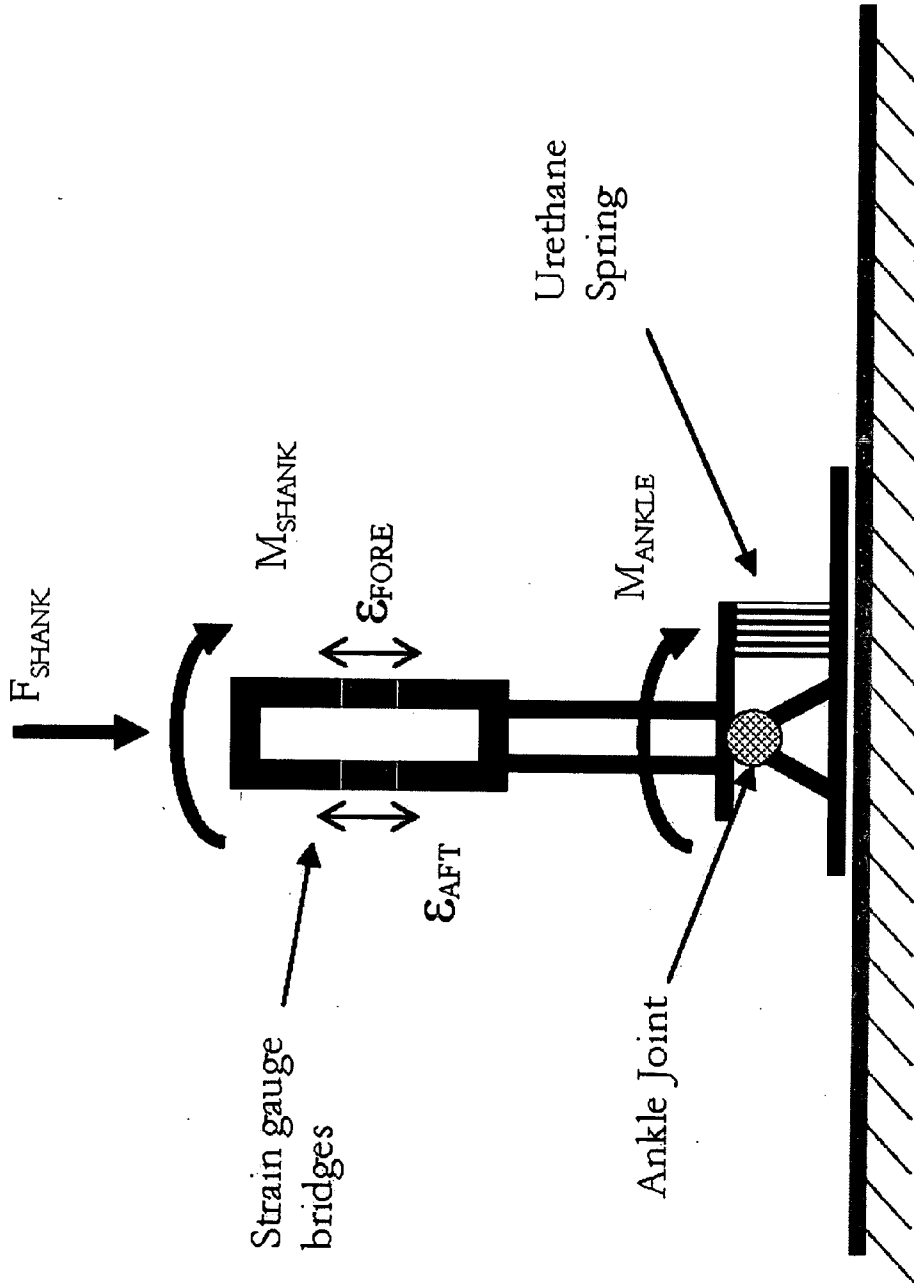

Fig. 55

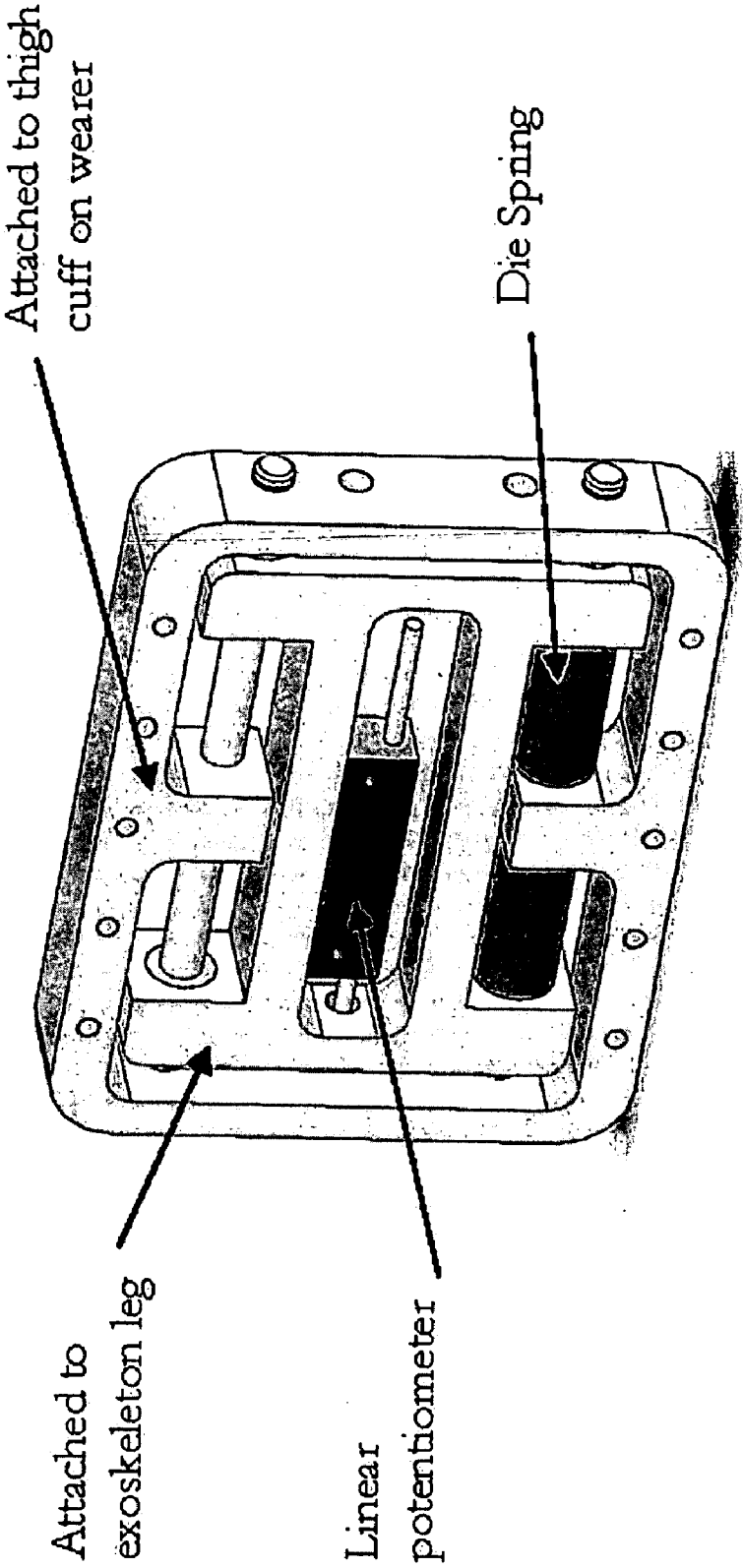

Fig. 56

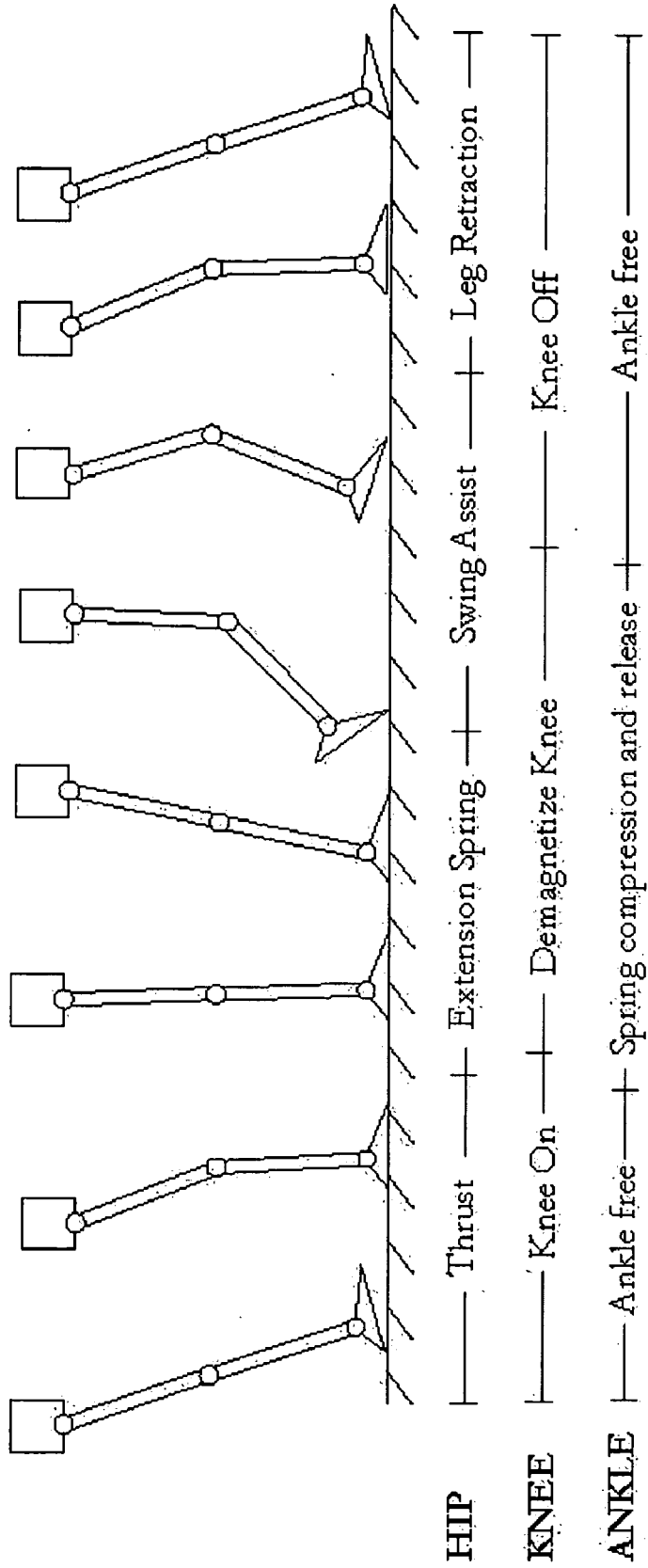
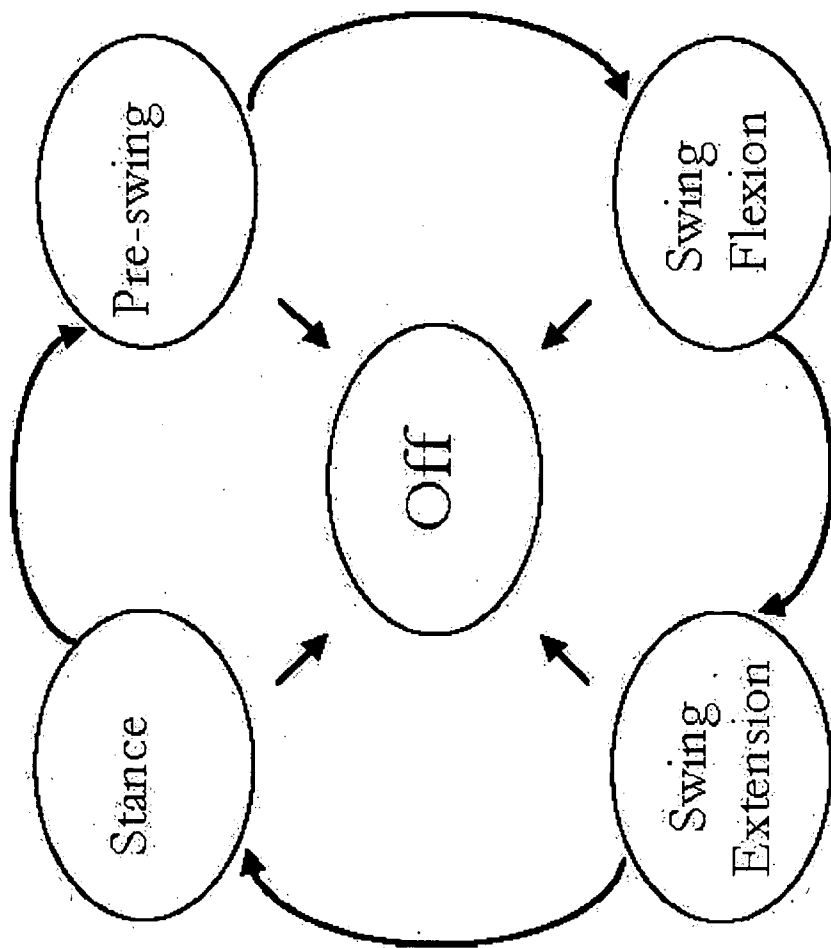

Fig. 57



Maximum Knee Angle

Fig. 58

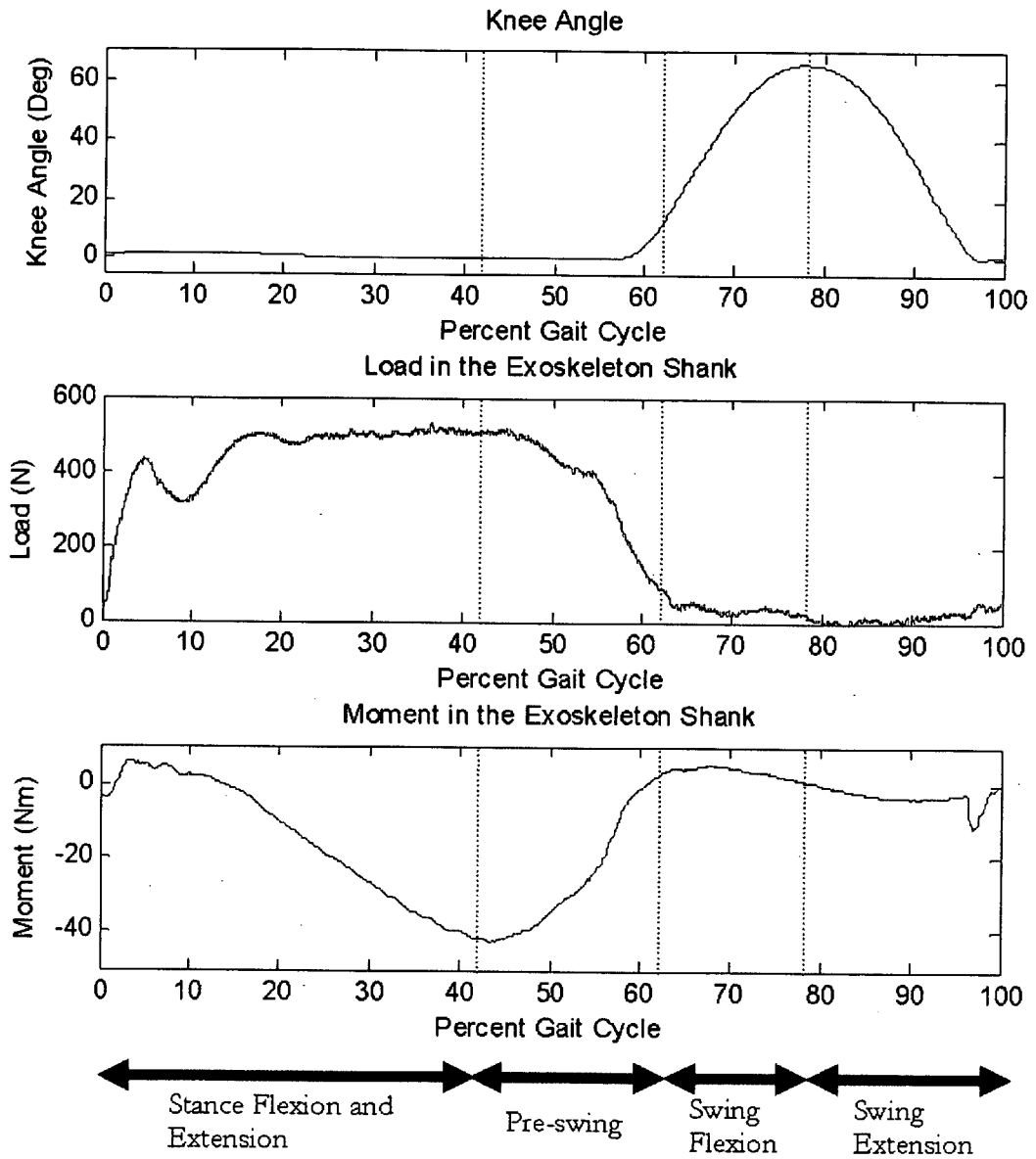

Fig. 59

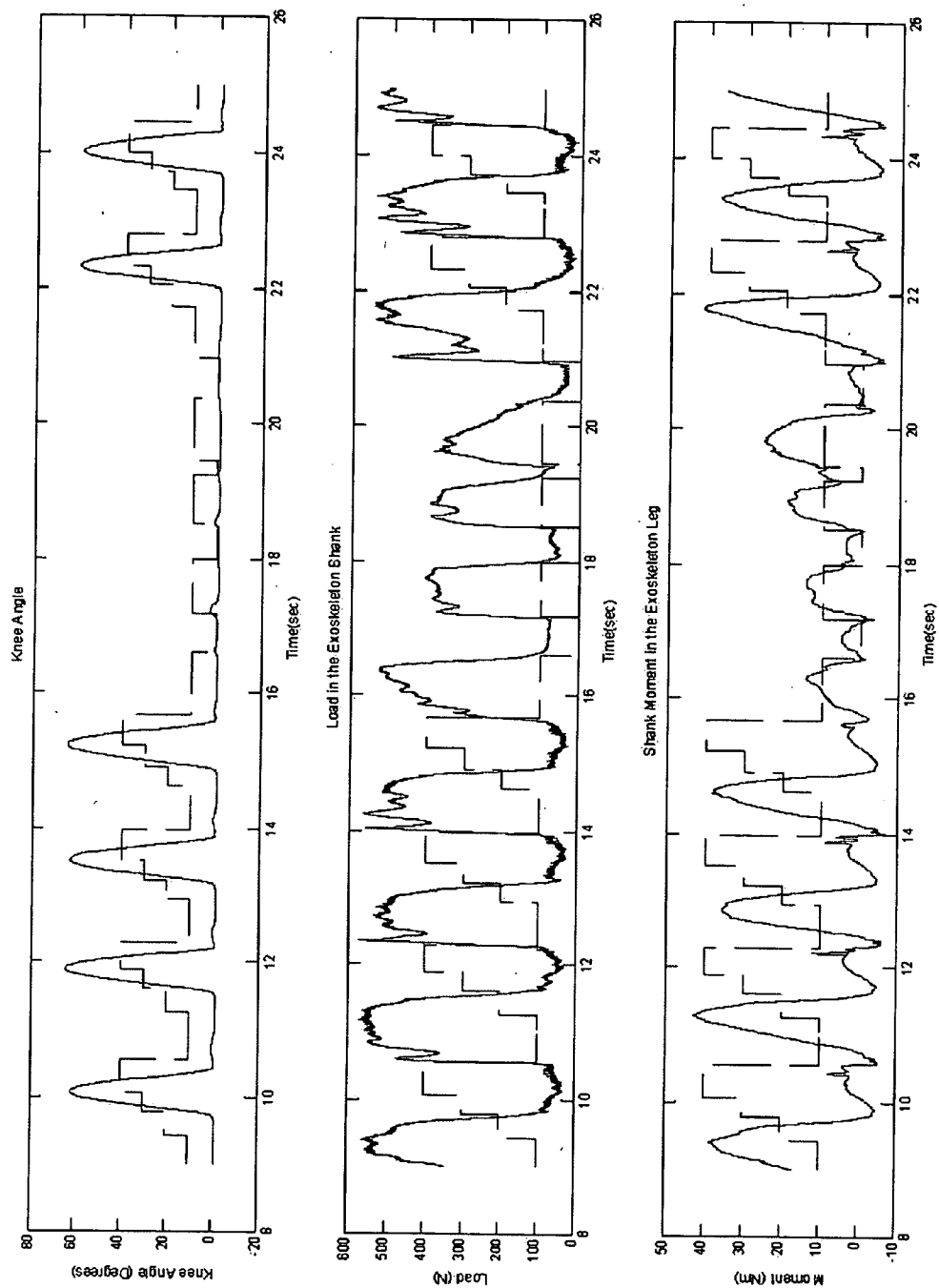

Fig. 60



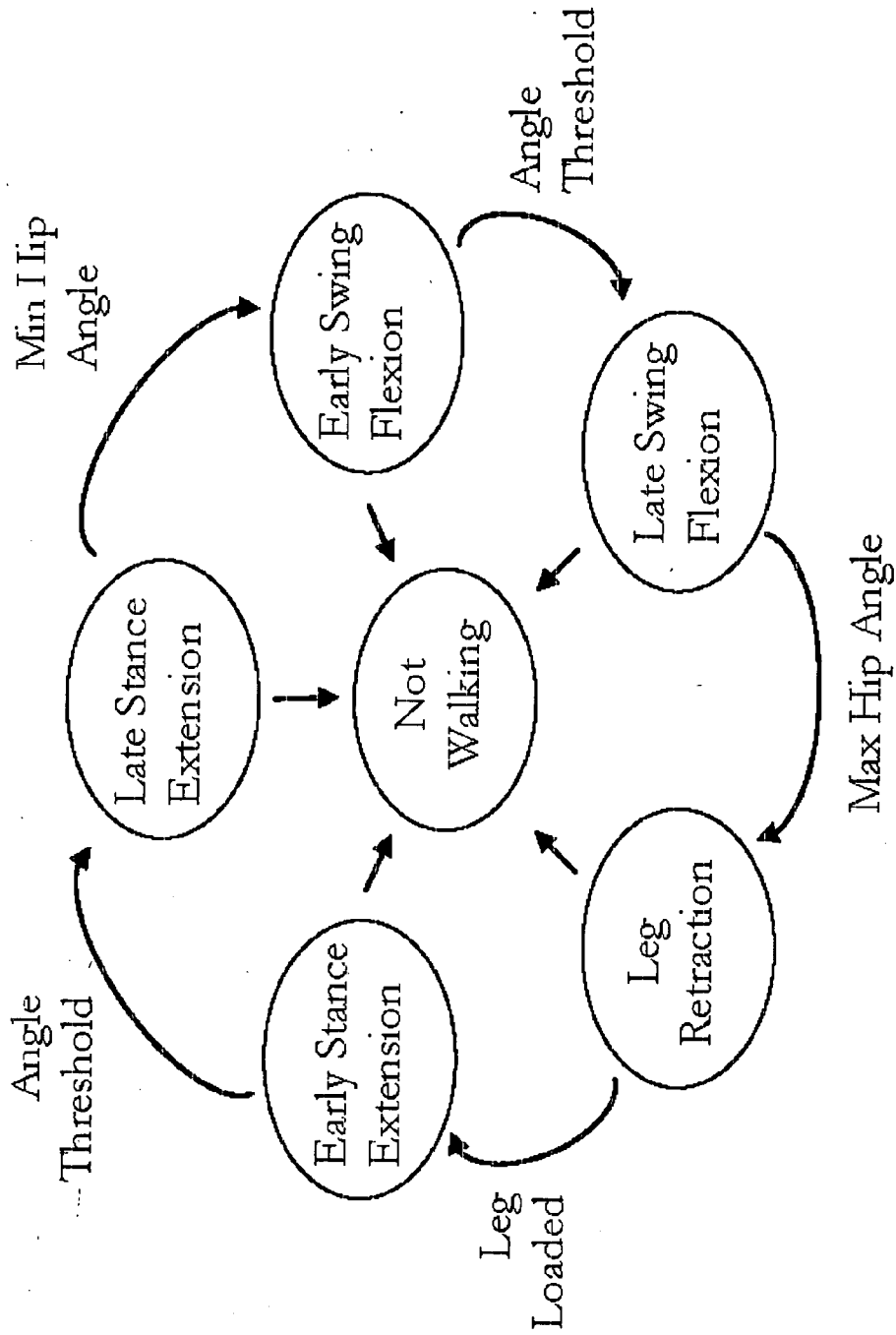

Fig. 61

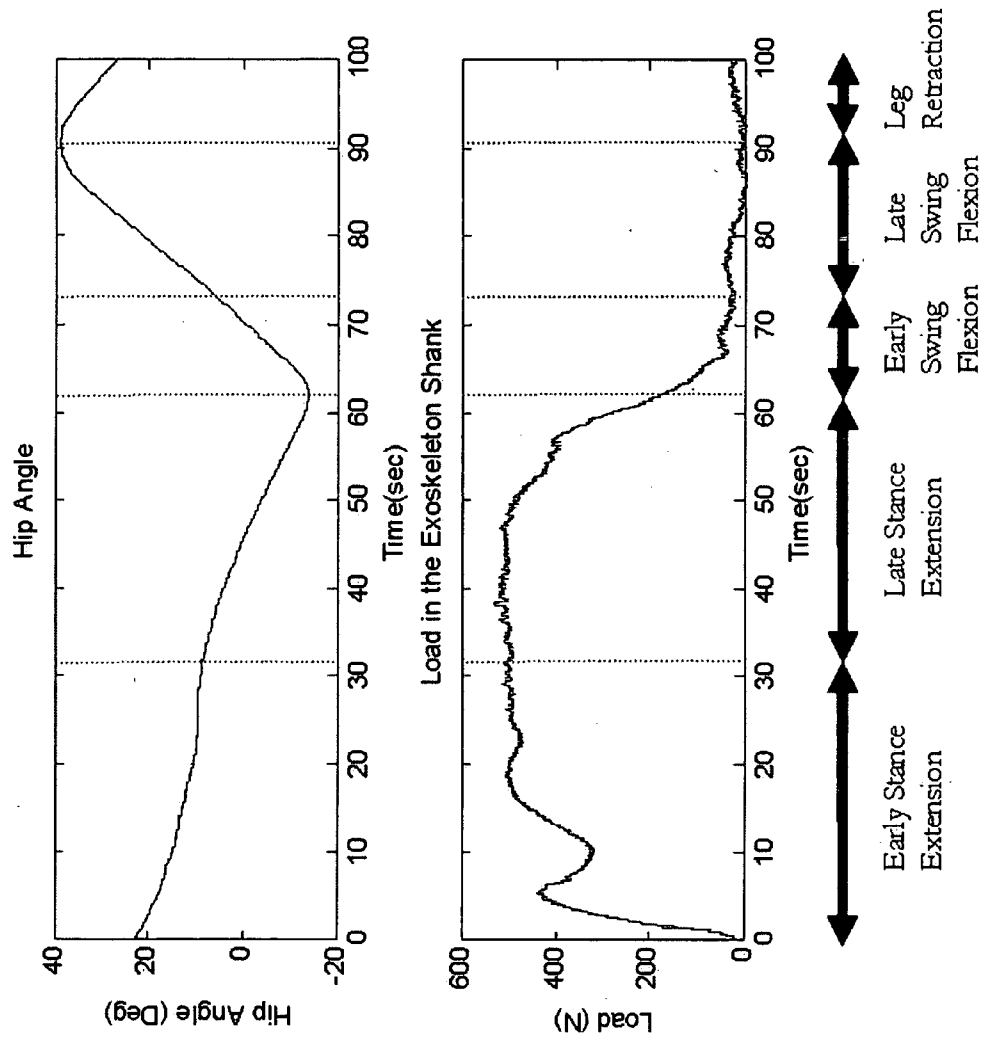

Fig. 62

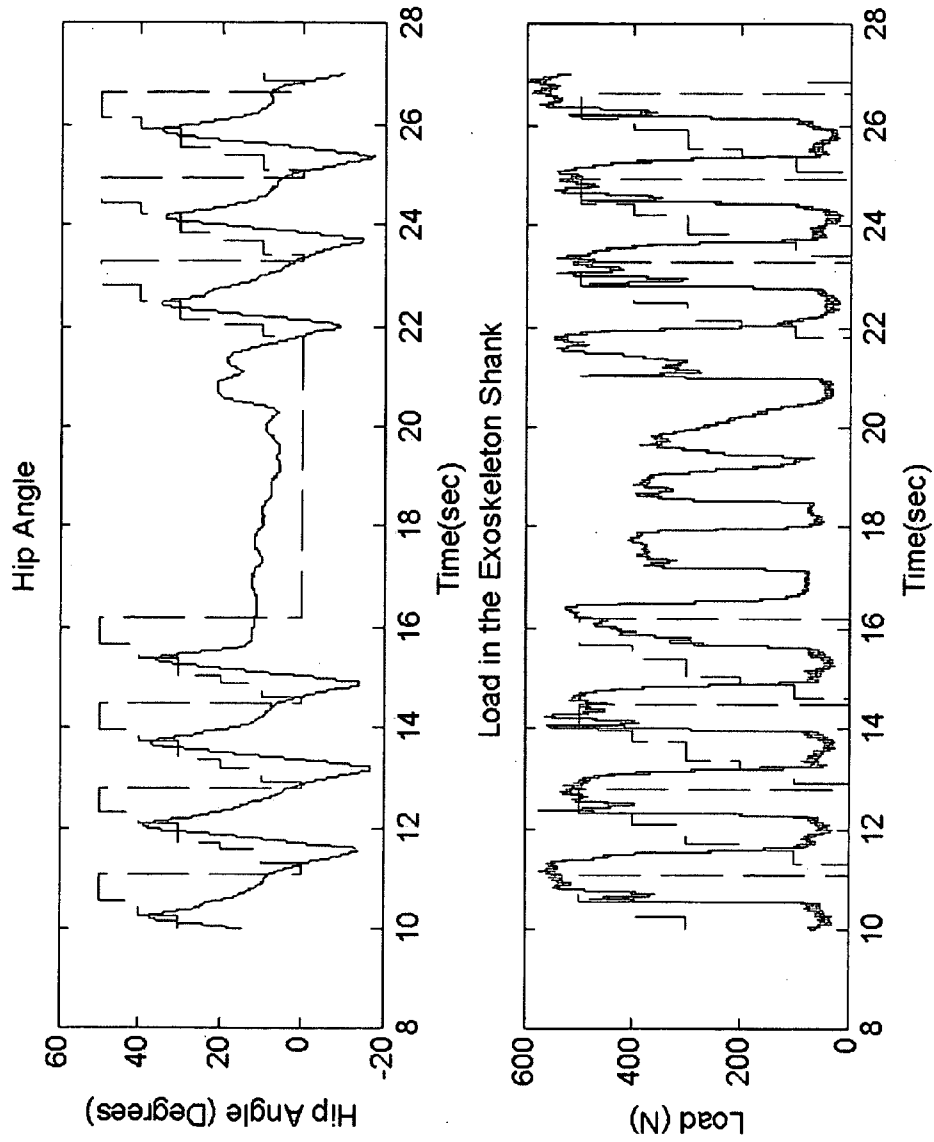

Fig. 63

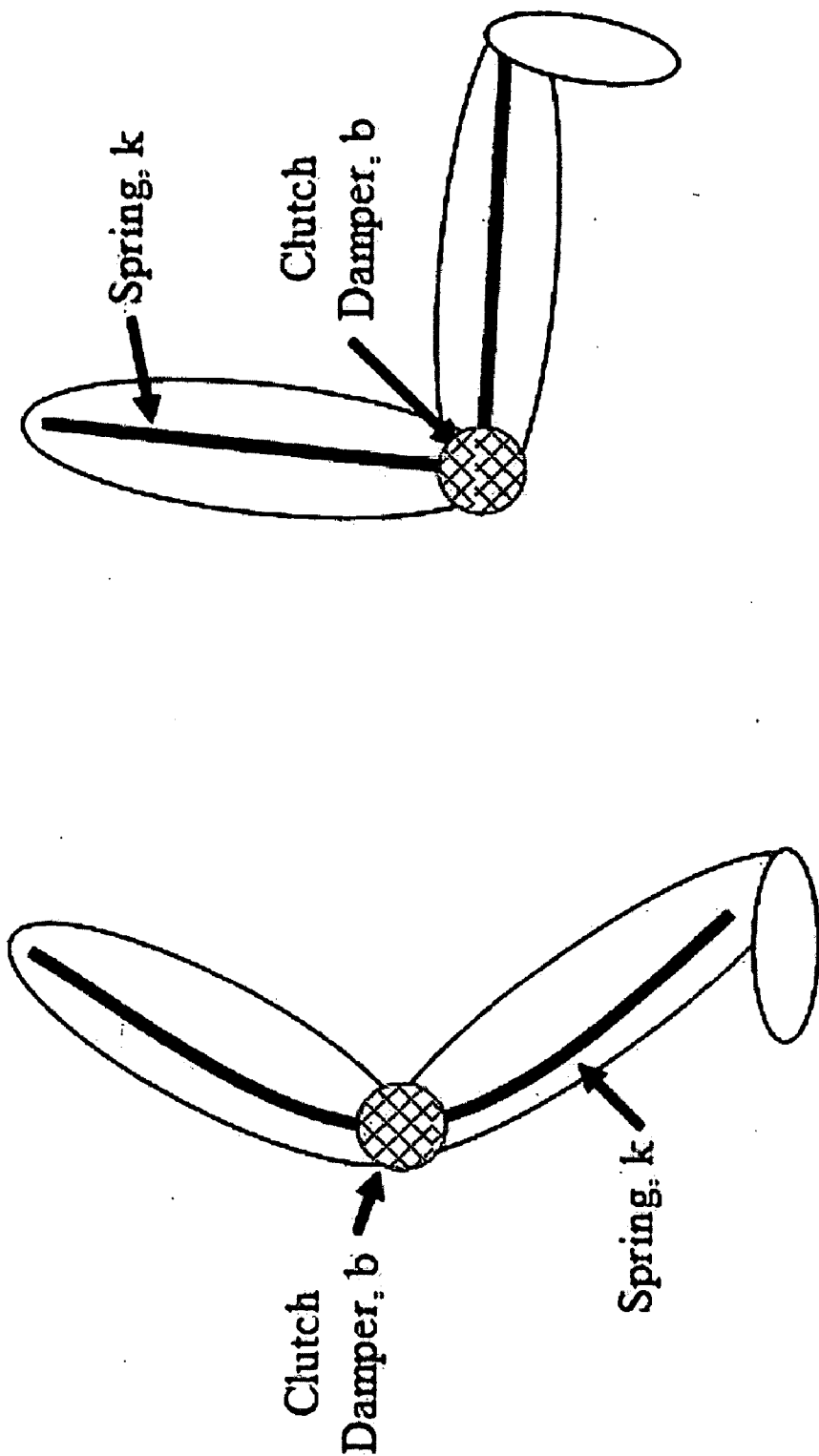

Fig. 64

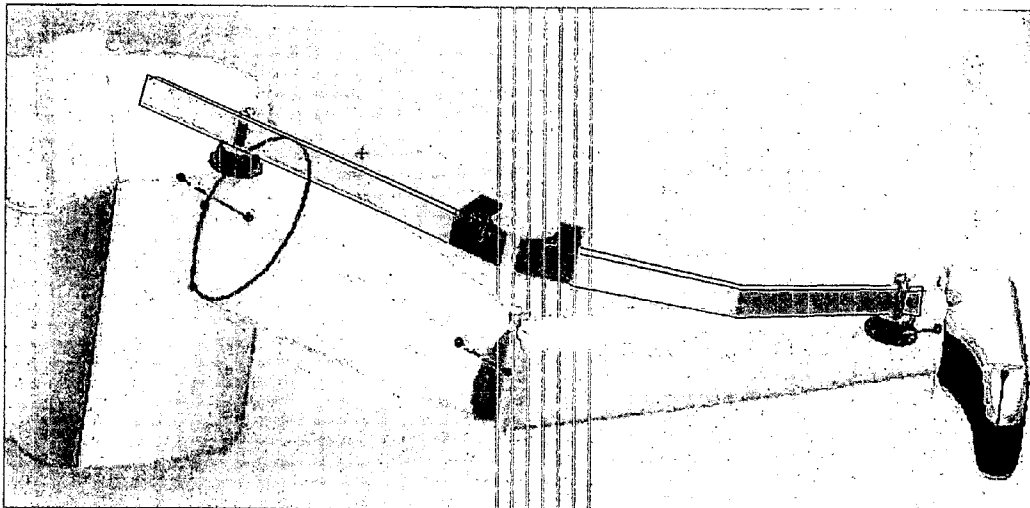

Fig. 65

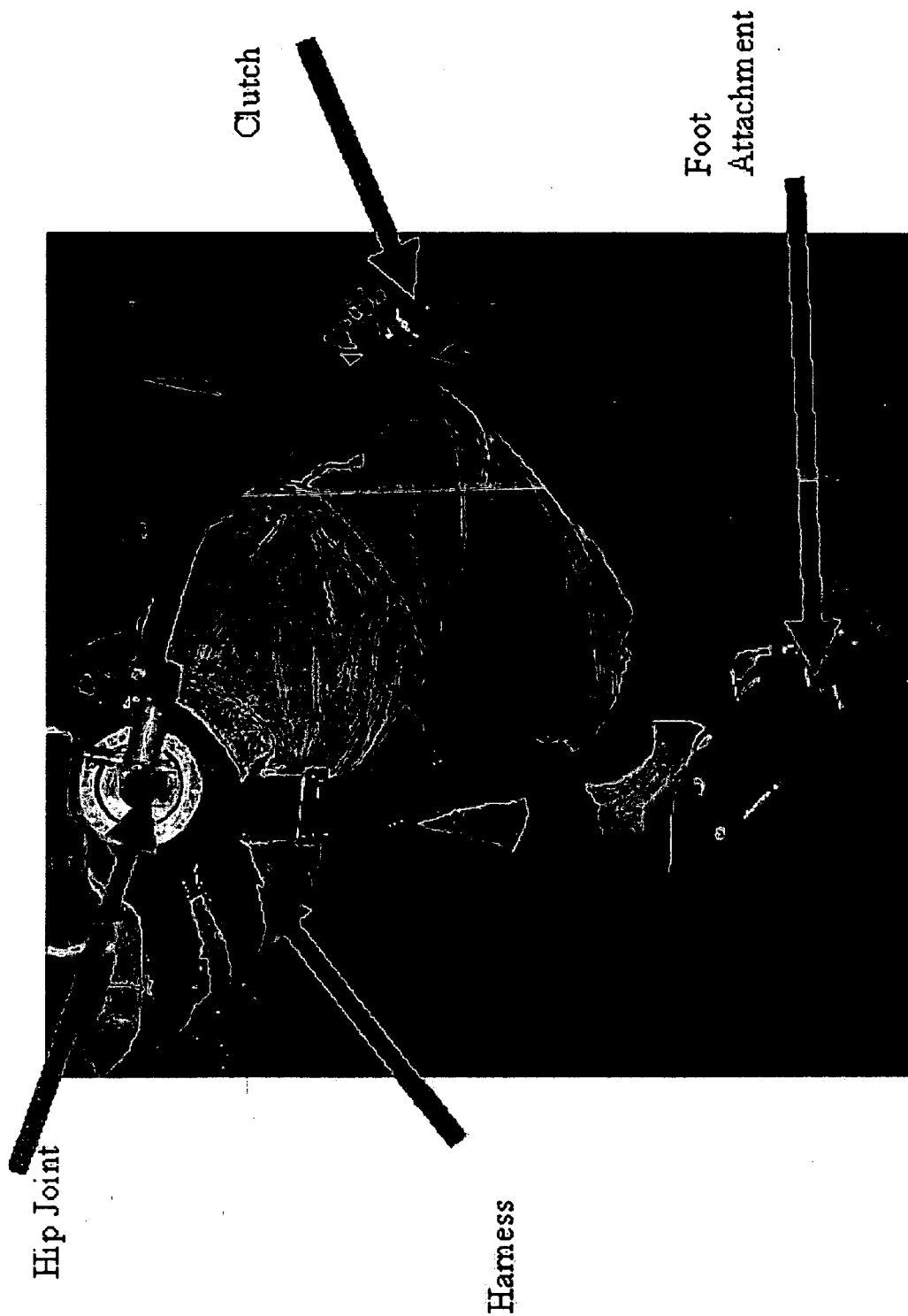

Fig. 66

**EXOSKELETONS FOR RUNNING AND WALKING**

**CROSS REFERENCE TO RELATED APPLICATIONS**

[0001] This application is a Non-Provisional of U.S. Patent Application Ser. No. 60/736,929 filed Nov. 15, 2006.

[0002] This application is a continuation in part of U.S. patent application Ser. No. 11/395,448 entitled "Artificial human limbs and joints employing actuators, springs, and Variable-Damper Elements" filed on Mar. 31, 2006 by Hugh M. Herr, Daniel Joseph Paluska and Peter Dilworth. Application Ser. No. 11/395,448 claims the benefit of the filing date of U.S. Provisional Patent Application Ser. No. 60/666,876 filed on Mar. 31, 2005 and the benefit of the filing date of U.S. Provisional Patent Application Ser. No. 60/704,517 filed on Aug. 1, 2005.

[0003] This application is also a continuation in part of U.S. patent application Ser. No. 11/499,853 entitled "Biomimetic motion and balance controllers for use in prosthetics, orthotics and robotics" filed on Aug. 4, 2006 by Hugh M. Herr, Andreas G. Hofmann and Marko B. Popovic. Application Ser. No. 11/499,853 claims the benefit of the filing date of, U.S. Provisional Patent Application Ser. No. 60/705,651 filed on Aug. 4, 2005.

[0004] This application is also a continuation in part of U.S. patent application Ser. No. 11/495,140 entitled "An Artificial Ankle-Foot System with Spring, Variable-Damping, and Series-Elastic Actuator Components" filed on Jul. 29, 2006 by Hugh M. Herr, Samuel K. Au, Peter Dilworth and Daniel Joseph Paluska. Application Ser. No. 11/495,140 claims the benefit of the filing date of U.S. Provisional Patent Application Ser. No. 60/704,517 filed on Aug. 1, 2005 and was also a continuation in part of the above-noted application Ser. No. 11/395,448.

[0005] This application claims the benefit of the filing date of each of the foregoing patent applications and incorporates the disclosure of each of the foregoing applications herein by reference.

**FIELD OF THE INVENTION**

[0006] This invention relates load bearing exoskeletal systems for running and walking.

**BACKGROUND OF THE INVENTION**

[0007] A leg exoskeleton could benefit people who engage in load carrying by increasing load capacity, lessening the likelihood of injury, improving efficiency and reducing the perceived level of difficulty. Lightweight, efficient exoskeletons could also be used to lower the metabolic cost of walking and running. By analyzing biomechanical data, design principles for efficient actuation strategies can be extracted. The exoskeleton must have a structure for supporting the weight of a payload or wearer. The system must also be capable of varying its position and impedance in a comparable manner to that of a normal, healthy biological limb and applying the appropriate torque and power at the joints to assist in forward locomotion. The current invention provides a novel architecture capable of achieving these many requirements.

[0008] Exoskeletons have been developed that amplify the strength of the wearer, apply assistive torques to the wearer's

joints and support a payload being carried by the wearer. General Electric (1968) developed and tested a prototype man-amplifier, a master-slave system called the Hardiman. It was a set of overlapping exoskeletons worn by the human operator and outer exoskeleton followed the motions of the inner exoskeleton which followed the motions of the human operator. Difficulties in human sensing, stability of the servomechanisms, safety, power requirements and system complexity kept it from walking.

[0009] The Berkeley Lower Extremity Exoskeleton is described in the paper by Chu, A., Kazerooni, H. and Zoss, A., 'On the Biomimetic Design of the Berkeley Lower Extremity Exoskeleton (BLEEX)', Proceedings of the 2005 IEEE International Conference on Robotics and Automation, Barcelona, Spain, pp. 4356-4363 (April, 2005). This lower extremity exoskeleton is attached at the human foot and at the back. The hip, knee and ankle joints are powered in the sagittal plane with linear hydraulic actuators. The system is powered with an internal combustion engine that is also supported by the exoskeleton. Sarcos has developed a similar exoskeleton with rotary hydraulics at the joints. Both systems sense the intent of the wearer and the robotic legs walk so as to track the human legs so the wearer does not 'feel' the exoskeleton.

[0010] Liu, X., Low, K. H., Yu, H. Y., (2004) 'Development of a Lower Extremity Exoskeleton for Human performance Enhancement', IEEE Conf. On Intelligent Robots and Systems, Sendai, Japan, describes initial prototypes and experiments of an exoskeleton to support a payload and are currently developing a full working prototype.

[0011] Vukobratovi, M., Borovac, B., Surla, D., Stoki, D. (1990), Biped Locomotion: Dynamics, Stability, Control, and Application, Springer-Verlag, Berlin, pp. 321-330, describes several exoskeletons to aid walking for paraplegics. Pre-defined trajectories were commanded by the devices and they had limited success in assisting subjects to walk. The devices were greatly limited by material, actuation and battery technology available at that time. Prof. Sankai from University of Tsukuba in Japan has developed an exoskeleton power assist system to aid people with a gait disorder. This system includes sensors for the joint angles, myoelectric signals of the muscles and floor sensors etc. in order to obtain the condition of the HAL and the operator.

[0012] Pratt, J., Krupp, B., Morse, C., Collins, S., (2004) 'The RoboKnee: An Exoskeleton for Enhancing Strength and Endurance During Walking', IEEE Conf. On Robotics and Automation, New Orleans, describes a powered, wearable device called the RoboWalker. The objective for this device was to augment or replace muscular function about the human knee by powering the knee joint using series elastic actuators.

[0013] Exoskeletons have been developed that amplify the strength of the wearer, apply assistive torques to the wearer's joints and support a payload for the wearer. Several exoskeleton design approaches have employed hydraulic actuators to power hip, knee and ankle joints in the sagittal plane. Such an exoskeleton design demands a great deal of power, requiring a heavy power supply to achieve system autonomy. For example, the Bleex developed at the University of California, Berkeley (Chu et al 2005) consumes approximately 2.27 kW of hydraulic power, 220 Watts of electrical power, and has a total system weight of 100 lbs.

This approach leads to a noisy device that has a very low payload to system weight ratio. Further, this type of exoskeleton is heavy, and if failure were to occur, could significantly harm the wearer.

#### SUMMARY OF THE INVENTION

[0014] The following summary provides a simplified introduction to some aspects of the invention as a prelude to the more detailed description that is presented later, but is not intended to define nor delineate the scope of the invention.

[0015] The detailed description with follows presents two exoskeleton embodiments of the present invention. In a first implementation, the exoskeleton assists the human user by transferring back pack payload mass to the ground. In a second, the exoskeleton carries the weight of the human. For both exoskeleton designs, a parallel exoskeleton structure is the fundamental architecture to transfer the backpack or human load forces to the ground in walking, running, or jumping.

[0016] For the backpack load-carrying exoskeleton for walking, the system interfaces to the human by means of shoulder straps, a hip harness, thigh cuffs, and a shoe attachment. Natural walking kinematics are preserved by collocating the exoskeleton hip, knee, and ankle joints to their biological counterparts. A cam mechanism is implemented at the hip joint to project the exoskeleton hip center near the biological hip center. The cam mechanism corrects for discrepancies between the exoskeleton and biological leg lengths during abduction and adduction. Passive spring elements are implemented at the hip and ankle and a variable damper is implemented at the knee. A non-conservative actuator can add to the hip flexion spring output at the hip in order to add significant positive power during walking. Control systems are proposed to control the exoskeleton as a function of gait cycle both for knee variable-dampers and hip motor components.

[0017] For the human-carrying exoskeleton for running and jumping, a parallel leaf spring architecture is shown that stores energy during jumping and running to efficiently transfer the weight of the wearer to the ground. Simple force or contact sensing may be employed to activate a clutch or variable damper at the knee. To activate the exoskeleton knees passively, a weight activated knee unit may be used where the knee automatically locks upon knee compression loading and unlocks when compression forces are no longer borne by the knee unit. Additional elements may be included in the leg design, including a motor in parallel with the leg spring that stores additional energy into the leg spring to augment leg extension in jumping or stair/hill ascent.

[0018] The parallel spring and variable damping architectures presented here offer a number of advantages over other devices. Having the exoskeleton architecture in parallel with the human leg allows the stability of the wearer to be maintained. Springs in series with the human raise the center of mass of the wearer and thus destabilize the wearer. Springs in parallel can be disengaged to allow the human leg to swing freely in the swing phase. Also by allowing the wearer's foot to remain in contact with the ground, overall stability of the wearer is maintained.

#### BRIEF DESCRIPTION OF THE DRAWINGS

[0019] In the detailed description which follows, frequent reference will be made to the attached drawings, in which:

[0020] FIG. 1 illustrates the eight phases of the walking cycle from heel strike to heel strike on the same foot;

[0021] FIG. 2 illustrates the inverted pendulum model of human walking;

[0022] FIG. 3 is a graph depicting how kinetic and potential energy are exchanged during walking;

[0023] FIG. 4 summarizes the effect of external forces on human walking;

[0024] FIG. 5 illustrates the regions of positive and negative work during walking;

[0025] FIG. 6 is a graph showing how hip angle varies during the walking cycle;

[0026] FIG. 7 is a graph showing how hip torque varies during the walking cycle;

[0027] FIG. 8 is graph showing how hip power varies during the walking cycle;

[0028] FIG. 9 is a graph showing the relationship between hip torque and hip angle;

[0029] FIG. 10 is a graph showing how knee angle varies during the walking cycle;

[0030] FIG. 11 is a graph showing how knee torque varies during the walking cycle;

[0031] FIG. 12 is a graph showing how knee power varies during the walking cycle;

[0032] FIG. 13 is a graph showing the relationship between knee torque and knee angle;

[0033] FIG. 14 is a graph showing how ankle angle varies during the walking cycle;

[0034] FIG. 15 is a graph showing how ankle torque varies during the walking cycle;

[0035] FIG. 16 is graph showing how ankle power varies during the walking cycle;

[0036] FIG. 17 is a graph showing the relationship between ankle torque and ankle angle;

[0037] FIG. 18 illustrates human running;

[0038] FIG. 19 illustrates the spring model of human running;

[0039] FIG. 20 is a photograph of backpack and connected leg exoskeleton where the load of the backpack is transmitted to the ground;

[0040] FIG. 21 is a photograph of a harness with a bicycle seat for supporting the wearer's weight on a leg exoskeleton;

[0041] FIG. 22 is a photograph of a carbon fiber pelvic harness and seat with a hip joint attachment to the exoskeleton legs;

[0042] FIG. 23 is a photograph of a carbon molded thigh and exoskeleton shin sections used in an alternative support structure;



[0043] FIG. 24 is a photograph showing an exoskeleton leg system adjacent to the human leg connected at the foot, thigh and pelvis;

[0044] FIG. 25 illustrates the main components of a walking load-carrying exoskeleton;

[0045] FIG. 26 illustrates the degrees of freedom of the exoskeleton structure;

[0046] FIG. 27 is a photograph of the exoskeleton system;

[0047] FIG. 28 is a further photograph showing side view exoskeleton system as worn;

[0048] FIG. 29 is a diagram showing the length change required for an exoskeleton leg during hip abduction-adduction;

[0049] FIG. 30 is a photograph of the cam assembly used to mitigate the change in leg length during abduction;

[0050] FIG. 31 is diagram illustrating the operation of the cam assembly;

[0051] FIG. 32 is a perspective view of the Exoskeleton spine assembly forming the backpack frame;

[0052] FIGS. 34 and 35 show the carbon fiber pelvic harness used in the exoskeleton;

[0053] FIG. 35 is a photograph of the thigh brace that attaches to a rotational joint allowing the human leg to rotate with respect to the exoskeleton leg;

[0054] FIG. 36 is a photograph of the ankle and foot structures used in the exoskeleton;

[0055] FIG. 37 is a photograph of a modified military boot with an integrated exoskeleton attachment point and heel spring;

[0056] FIG. 38 is a schematic depiction of a series elastic actuator for the hip exoskeleton section;

[0057] FIG. 39 is a perspective view of a series elastic actuator for the hip exoskeleton section;

[0058] FIG. 40 are Bode diagrams of the series elastic actuator for the fixed end condition;

[0059] FIG. 41 are Bode diagrams of the series elastic actuator with an equivalent load mass of 350 kg.

[0060] FIGS. 42A and 43B are graphs of hip torque and hip angle during closed loop testing of the actuator;

[0061] FIGS. 43 and 44 are photographs of hip structure with a hip spring for storing energy during late hip extension and released as the leg lifts from the ground;

[0062] FIG. 45 is a diagram illustrating the moment created by the load during standing;

[0063] FIG. 46 illustrates how the abduction spring is compressed during the stance phase of walking;

[0064] FIG. 47 is a photograph showing the knee joint of the exoskeleton containing a variable damper;

[0065] FIG. 48 is a graph of current vs. braking torque for the variable damper used in the knee joint;

[0066] FIG. 49 is an illustration showing how energy is stored and released by the ankle spring;

[0067] FIG. 50 is a perspective view illustrating the exoskeleton ankle design for the integrated exoskeleton and shoe;

[0068] FIG. 51 is a photograph showing the bidirectional spring at the ankle;

[0069] FIG. 52 is a diagram showing the operation of a mechanism for transferring energy from the hip and knee mechanical work to the ankle work;

[0070] FIG. 53 is a schematic block diagram of the electronic components used to control hip actuators and variable dampers at the knees;

[0071] FIG. 54 is a photograph illustration the location of sensors on an exoskeleton leg;

[0072] FIG. 55 is a schematic depiction of the exoskeleton shank and foot;

[0073] FIG. 56 depicts the thigh cuff sensor for measuring the force between the exoskeleton and the human thigh;

[0074] FIG. 57 is a diagram that summarizes the actuation control of the hip and knee during the gait cycle, as well as the operation of the ankle spring;

[0075] FIG. 58 is a state machine diagram of the knee controller;

[0076] FIG. 59 shows the sensor data for the exoskeleton during a single gait cycle;

[0077] FIG. 60 shows the state machine for the exoskeleton during walking;

[0078] FIG. 61 is a state machine diagram for the hip controller;

[0079] FIG. 62 shows the sensor data from the leg during walking showing hip angle and load;

[0080] FIG. 63 shows the sensor data for hip angle and load when a person is walking normally;

[0081] FIG. 64 shows the motion of the knee joint clutch and the leg springs for an exoskeleton leaf spring mechanism;

[0082] FIG. 65 shows a solid model of the leaf spring architecture; and

[0083] FIG. 66 is a photograph of the parallel leaf spring exoskeleton in a working implementation.

#### DETAILED DESCRIPTION

[0084] Biomechanics of Walking and Running In this section the biomechanics of human walking and running are examined. In later sections, these biomechanics will motivate the design of the exoskeleton system described herein.

[0085] Walking

[0086] Walking consists of two phases, a stance phase and a swing phase. During the early stance phase, the muscles at the hip, knee and ankle generally act to decelerate and stabilize the body. At the end of stance, the ankle undergoes powered plantar flexion where it provides the energy to power the body forward and upwards. Additionally, at the start of the swing phase, the hip gives a burst of energy to raise the lower leg from the ground surface. FIG. 1 outlines eight phases of the walking cycle.

[0087] The kinetic energy and gravitational potential energy of the center of mass are approximately 180 degrees out of phase in walking. At mid-stance in walking, the gravitational potential energy is at its maximum and the kinetic energy is at its minimum. Because these energies are approximately 180 degrees out of phase with each other and their fluctuations are similar in magnitude, substantial pendulum-like exchange occurs in walking. In human walking, as much as 60-70% of the mechanical energy required to lift and accelerate the center of mass is conserved by this energy transfer mechanism. Mechanical energy savings are maximized at moderate walking speeds, and fall toward zero at very low and very high walking speeds.

[0088] FIG. 2 illustrates the inverted pendulum model of human walking and FIG. 3 is a graph showing the manner in which potential energy and kinetic energy are exchanged during walking.

[0089] Metabolic Studies on External Forces Applied During Walking

[0090] Walking metabolism is set by muscles that act to perform work on the center of mass, swing the legs relative to the center of mass, and support the body weight. A number of researchers have performed experiments on subjects while walking where they apply external loads in the vertical and horizontal direction in order to examine the effect on metabolic rate and muscle activity. The results are summarized in FIG. 4

[0091] Motivation for a Semi-Active Approach

[0092] Evidence from biology and passive walkers suggests that legged locomotion can be very energy efficient. The exchange between potential and kinetic energy suggests that walking may be approximated as a passive mechanical process. Passive walkers reinforce this fact. In such a device, a human-like pair of legs settles into a natural gait pattern generated by the interaction of gravity and inertia. Although a purely passive walker requires a modest incline to power its movements, researchers have enabled robots to walk on level ground by adding just a small amount of energy solely at the hip or the ankle joint. See Wisse, Martijn, *Essentials of Dynamic Walking, Analysis and Design of two-legged robots*, Phd Thesis (2004), Technical University of Delft. Recent evidence suggests that elastic energy storage is also critical for efficient bipedal ambulation. Palmer, M. L., (2002) 'Sagittal Plane Characterization of Normal Human Ankle Function Across a Range of Walking Gait Speeds' MS Thesis, MIT, showed that by characterizing the human ankle during the stance phase of walking in terms of simple mechanical spring elements, sagittal plane dynamics of a normal ankle can be reproduced at least at slow to moderate walking speeds. Further, van den Bogert, van den Bogert, A. J. (2003), 'Exotendons for assistance of human locomotion'. *Biomedical Engineering Online*, 2:17, showed in numerical simulation that an exoskeleton using passive elastic devices can substantially reduce muscle force and metabolic energy in walking.

[0093] Muscle Activity in Gait

[0094] FIG. 5 illustrates the significant regions of positive and negative power during the gait cycle. Specifications for actuation components as well as control strategies are extracted from angle, torque and power data at the human hip, knee and ankle joints in the sagittal plane.

[0095] Many muscles responsible for walking contract isometrically to allow maintenance of upright posture against gravity or transfer or storage from one limb segment to another. Brief bursts of more energy expensive shortening contraction of muscle are added when needed to provide power for forward motion. Positive work is performed when a muscle is concentrically contracting. Negative work is said to be performed when a muscle is eccentrically contracting (elongating while active). Much muscle activity in walking is isometric or eccentric. Negative work allows the limbs to absorb energy while resisting the pull of gravity yet remain metabolically efficient. Positive work of muscles during walking allows acceleration of limbs and powers such activities as push off and extension of the hip after foot strike.

[0096] Joint Sagittal Plane Angles, Torques and Powers

[0097] Human walking data were used in order to specify the design requirements for actuation at the exoskeleton joints. A number of assumptions were made in the application of the human biomechanical data to exoskeleton design. The first is that the exoskeleton carries its own weight, power supply and payload. The second assumption is that joint torques and joint powers scale linearly with mass. This second assumption seems reasonable given that increases in vertical ground reaction force have been found to be proportional to increases in the load being carried as described by Lloyd R., & Cooke C. B. (2000) 'Kinetic changes associated with load carriage using two rucksack designs' *Ergonomics* 43(9), 1331-1341. The third assumption is that the exoskeleton will not greatly affect the gait of the wearer. This is important because changes in gait have been shown to increase the physiological energy expended during locomotion as described by McMahon, T. A., Valiant, G., & Frederick, E. C. (1987). *Groucho Running*, *Journal of Applied Physiology*, 62(6) 2326-2337.

[0098] Hip Kinematics and Kinetics

[0099] FIGS. 6 and 7 graph hip angle and torque scaled for a 60 kg. person. During normal walking the human hip joint follows an approximate sinusoidal pattern with the thigh flexed forward on heel strike and then the hip moves through extension during stance as the body is pivoted over the stance leg in a pendulum-like motion. Positive power is required on heel-strike to raise the center of mass of the human over the stance leg. A peak negative hip torque of approximately -60 Nm is experienced in late stance hip extension just before the leg enters the swing phase. A maximum positive torque of about 50 Nm occurs during the swing phase as the hip muscles provide energy to swing the leg forward. This action is sometimes referred to as "pull off," and is the muscular system's second largest contribution of propulsive power during the gait cycle.

[0100] The power profile at the hip as a function of gait cycle is shown in FIGS. 5 and 9. H1 is a small region of positive power, not always present, which corresponds to concentric hip extensor activity during loading response, H2 is a region of negative power, corresponding to eccentric hip flexor activity during mid-stance and H3 is a region of positive power, corresponding to concentric activity in the hip flexors during pre-swing and initial swing. Hip torque versus angle is shown on the left plot for a walking speed of 0.8 m/s.

[0101] Hip abductors move from eccentric to isometric to concentric activity, elevating the pelvis in preparation for

swing. Following this action, there continues to be eccentric hip flexor activity at the hip. During mid-stance the center of gravity of the body has reached its highest point and is carried forward by momentum. Eccentric hip flexor activity resists the body during this falling period. The hip contributes to propulsion as it shifts from eccentric to concentric activity which will advance the extremity into the swing phase by lifting the leg from the ground surface and then swinging it forward. This region is the muscular system's second largest contribution of propulsive power during the gait cycle.

[0102] The hip joint is the preferred location for a non-conservative actuator as proximal mass is less expensive metabolically in walking than distal mass. An actuator could assist in adding power in the H1 and H3 regions. From FIGS. 8 and 9 it can also be seen that a spring placed at the hip joint could absorb energy in the negative power region of H2 and release that stored energy during the H3 region to assist in swinging the leg forward. A passive hip spring exoskeleton joint design is very appropriate for slow walking speeds. In FIG. 9 an approximate linear relationship can be seen between the hip torque and angle for slow walking (0.8 m/s). As well as adding power throughout the gait cycle, a force-controllable actuator at the hip could be programmed to experiment with various hip stiffness values.

[0103] Knee Kinematics and Kinetics

[0104] FIGS. 10 and 11 show plots of the angle and torque profile of the human knee joint as a function of gait cycle. There is an initial knee flexion-extension period as the leg accepts weight after heel strike, and then a rapid knee flexion during terminal stance occurs to allow for foot clearance during the swing phase. On heel strike the knee bends slightly while exerting a maximum negative torque of 40 Nm as the weight is transferred to the leg.

[0105] FIGS. 12 and 13 depict the power of the knee as a function of gait cycle and it can be seen that the power is largely negative. At heel strike there is a region of negative power followed by positive power as the knee goes through stance flexion-extension. This is followed by a period of negligible joint power as the knee is passively extended as the quadriceps are inactive as ground reaction forces, as well as activity in the ankle plantar flexors keep the knee stabilized in extension due to the ground reaction force. For a large part of swing, the leg has a pendulum-like motion, and the knee undergoes eccentric activity to dampen the swinging leg.

[0106] FIGS. 12 and 13 show the knee joint power profile scaled for a 60 kg person as a function of gait cycle. K1 is a region of negative power, corresponding to eccentric knee extensor activity during the loading response, and K2 is a region of positive power, corresponding to concentric knee extensor activity during mid-stance. K3 is a region of negative power, corresponding to eccentric activity in the rectus femoris during pre-swing, and K4 is a region of negative power, corresponding to eccentric activity in the hamstrings during terminal swing. Plotted on the right is knee angle versus knee torque for the walking cycle. It can be seen that the knee can be modeled as a variable-damping device throughout the gait cycle with the exception of region K2.

[0107] It can be seen in the knee torque vs. angle plot that during early stance phase the knee behaves like a spring, but

for the remainder of the gait cycle, the knee response can be modeled as a variable damper. From this observation, a variable-damping device at the knee seems sufficient for actuation at the exoskeleton knee.

[0108] Ankle Kinematics and Kinetics

[0109] FIGS. 14 and 15 show ankle angle and torque profiles scaled for a 60 kg. person. The ankle joint experiences approximately 15 degrees of rotation in both directions throughout the gait cycle. During the mid and late stance phases of walking the ankle eccentric plantar flexor activity creates negative joint torque as the ankle controls the forward movement of the center of mass. The peak torque experienced by the ankle is approximately 90 Nm.

[0110] FIGS. 16 and 17 show the joint power profile scaled for a 60 kg person as a function of gait cycle. A1 is a region of negative power, corresponding to eccentric plantar flexor activity at the ankle during mid-stance and terminal stance, and A2 is a region of positive power, corresponding to the concentric burst of propulsive plantar flexor activity during pre-swing. On the left is a plot of ankle angle versus ankle torque for the walking cycle. It can be seen that the ankle behaves like a spring at a walking speed of 0.8 m/s.

[0111] For slow walking the region of negative work, A1, is approximately equal to the region of positive power, A2 suggesting that a spring at the ankle may be an appropriate choice for actuation the exoskeleton ankle. At faster walking speeds A2 is significantly larger indicating that a non-conservative actuator is required. A linear fit yields a spring constant for the ankle of 229 Nm/rad for this walking speed. This implies that, for slow walking, a spring could be placed at the ankle of the exoskeleton, thus helping to minimize the negative effects of distal exoskeleton mass.

[0112] Running

[0113] A simple model of running is shown in FIG. 18. A spring-mass model and a stick figure representation of a single stance phase of human running. The model consists of a linear spring representing the leg and a point mass equivalent to body mass. This figure depicts the model at the beginning of the stance phase (left-most position), at the middle of the stance phase (leg spring is oriented vertically), and at the end of the stance phase (right-most position). For running, the biological leg can be modeled as a linear spring between the runner's center of mass and the ground. The center of mass has a parabolic trajectory as seen in the figure below.

[0114] Technical Description

[0115] Exoskeleton for Walking

[0116] Carrying the Human vs. Carrying a Backpack

[0117] Based on the results of Farley & McMahon as well as Gottschall and Kram, an exoskeleton or orthosis that supports the weight of the wearer and that provides a forward propulsive force will dramatically lower metabolic transport requirements. See Farley, C. & McMahon, T. (1992), 'Energetics of walking and running: insights from simulated reduced-gravity experiments', *The American Physiological Society* pp. 2709-2712 and McMahon, T. A., Valiant, G., & Frederick, E. C. (1987). *Groucho Running*, *Journal of Applied Physiology*, 62(6) 2326-2337

[0118] The weight of the wearer can be supported with various types of harnesses and pelvic attachments.

[0119] The first of these designs is a compliant off the shelf stunt harness shown in FIG. 19 that employs a back pack and leg exoskeleton arrangement where the load of the back pack is transmitted to the ground. A harness is flexible, and causes a problem with the exoskeleton side mounts. The mounts, when the exoskeleton is loaded, bend inward digging into the wearer above the pelvis.

[0120] As a resolution to this difficulty, the arrangement shown in FIGS. 20 and 21 employs a carbon fiber pelvic girdle with a seat and strapping system. The device provides rigid mounting planes on the sides of the pelvis for the exoskeleton legs. A fabricated, light-weight carbon composite belt and seat with supporting straps is coupled to the exoskeleton for supporting a user's weight and a bike seat or the like is used to transfer the weight of the user to the ground surface.

[0121] Intimate Form-Fit vs. Adjacent Robotic Structure

[0122] In the design of an exoskeleton to support the weight of the wearer and to provide a forward propulsive force, two strategies are pursued. The first strategy, shown in FIG. 22, is a lightweight, intimate carbon fiber composite suit molded to the wearer at the foot, shank, thigh and pelvis, and the second strategy, shown in FIG. 24 is an adjacent robotic leg in parallel with the human leg connected at the foot, thigh and pelvis.

[0123] In the arrangement shown in FIG. 23, electromagnetic clutches are placed at the exoskeleton knee joints, and series elastic actuators power the hips. This strategy requires torso, thigh, shank and foot attachments to provide support at the hip, knee and ankle joint. The carbon fiber structure is custom fit to the wearer. Using this method it is possible that the interface between the human and the exoskeleton, in the regions of the shank and thigh, take some of the weight of the wearer. This approach lends itself to providing power to augment the wearer's hips due to the high stiffness of the thigh and torso sections, although it would be difficult to generalize the carbon sections to many users.

[0124] The second architecture shown in FIG. 24, instead of the molded carbon fiber structure, employs a parallel robotic leg adjacent to the human leg. This architecture is deemed preferable to the molded architecture because 1) the system only interfaces with the human at the foot, thigh and pelvic; and 2) the system is more readily adjustable to different human morphologies.

[0125] 3.1.3 Overall Joint Actuation Strategy

[0126] Two exoskeleton joint architectures are examined for walking. The main components of the walking, load-carrying exoskeleton are shown in FIG. 25.

[0127] A first architecture consists of springs at the hip 2501, a variable impedance device at the knee 2503, and springs at the ankle 2505. In a second architecture, non-conservative actuators are placed at the hip 2501 to further augment hip flexion and extension to examine the effect of adding power at desired instances throughout the gait cycle.

[0128] A state-machine control strategy is written based on joint angle sensing as well as ground-exoskeleton force interaction sensing. When the human foot is on the ground,

the exoskeleton transfers the forces from the loaded backpack to the ground. For level ground ambulation, a passive extension spring at the hip 2501 engages in mid-stance and stores energy and then that stored energy is released at the beginning of the hip flexion phase to assist in lifting the exoskeleton and human leg from the ground surface.

[0129] Using the second exoskeleton architecture, positive power from hip actuators is added at the hip 2501 during the stance phase to propel the mass of the human and the payload 2507 forward, and to cancel the mass of the human and exoskeleton leg during the swing phase. For level ground ambulation, the variable damper at the knee 2503 is turned on during early stance to provide support for the load and is then switched off during terminal stance and swing to minimize resistance at the knee joint. For slope descent, the variable-damper knee is turned on throughout the entire stance period to assist the human knee in lowering the backpack mass 2507. Finally, the passive spring structure at the ankle 2505 engages in controlled dorsiflexion to store energy that is later released to assist in powered plantar flexion.

[0130] Hybrid Actuators

[0131] The above-noted co-pending application Ser. No. 11/395,448 entitled "Artificial human limbs and joints employing actuators, springs, and Variable-Damper Elements" filed on Mar. 31, 2006 describes Biomimetic Hybrid Actuators which use an electric motor for supplying positive energy to and storing negative energy from one or more joints which connect skeletal members, as well as elastic elements such as springs, and controllable variable damper components, for passively storing and releasing energy and providing adaptive stiffness to accommodate level ground walking as well as movement on stairs and surfaces having different slopes. These hybrid actuators are described in detail in application Ser. No. 11/395,448, the disclosure of which is incorporated herein by reference. Actuators used to implement hip, knee and ankle joints are described which may be used to implement an exoskeleton of the type contemplated by the present invention.

[0132] These hybrid actuators manipulate first and second skeletal members connected at one or more joints for movement relative to one another. A motor applies a force to move one member with respect to the other. One or more passive elastic members are connected between the skeletal members for storing energy when the members move relative to one another in one direction and for releasing energy when the members relative to one another in the opposite direction, and one or more controllable variable damping elements dissipate mechanical energy to arrest the relative motion of the first and second members at controllable times. Some of the hybrid actuators provide additional force by using a catapult mechanism in which the motion of the members is arrested by a controllable damping element while the motor stores energy in one or more elastic members and the damping element thereafter releases the members which are then moved by the energy stored in the elastic member. One or more damping elements may be operatively connected in parallel with the motor to arrest its motion while energy is stored in one or more elastic members and thereafter the motor parallel damping element releases the motor to release the energy previously stored in the elastic member.

[0133] The hybrid actuator may employ an elastic member operatively connected in series with a controllable damping member. When the controllable damping member exhibits a higher damping level, energy is stored in the series elastic member and thereafter, when the controllable damping member exhibits a lower damping level, energy is released from the series elastic member. The motor in the hybrid actuator may apply torque to a joint or joints through a gearbox and a first controllable variable damping element can be employed to arrest the motion of the motor at controllable times, and a further controllable variable damping element operatively connected between the motor and the gearbox can disconnect the motor and the gearbox at controllable times, such that the gearbox can be used as a damping element to arrest the motion of skeletal members at some times, and be used to apply force to move the members at other times.

[0134] As described in application Ser. No. 11/395,448, an artificial ankle may employ an elastic member operatively connected in series with the motor between the shin member and the foot member to store energy when the relative motion of the foot and shin members is being arrested by a controllable variable damping element and to thereafter apply an additional torque to the ankle joint when the variable damping element no longer arrests the relative motion of the two members.

[0135] Copending patent application Ser. No. 11/495,140 entitled "An Artificial Ankle-Foot System with Spring, Variable-Damping, and Series-Elastic Actuator Components" filed on Jul. 29, 2006 describes an artificial ankle and foot system in which a foot and ankle structure is mounted for rotation with respect to a shin member at an ankle joint. The foot and ankle structure includes a curved flexible elastic foot member that defines an arch between a heel extremity and a toe extremity, and a flexible elastic ankle member that connects said foot member for rotation at the ankle joint. A variable damper is employed to arresting the motion of said foot and ankle structure with respect to said shin member under predetermined conditions, and preferably includes a stop mechanism that prevents the foot and ankle structure from rotating with respect to the shin member beyond a predetermined limit position. The variable damper may further include a controllable damper, such as a magnetorheological (MR) brake, which arrests the rotation of the ankle joint by controllable amount at controlled times during the walking cycle. The ankle and foot system may include an actuator motor for applying torque to the ankle joint to rotate the foot and ankle structure with respect to said shin member, and/or a catapult mechanism comprising a series elastic member operatively connected in series with the motor between the shin member and the foot and ankle structure in which the series elastic member stores energy from the motor during a first portion of each walking cycle and then releases the stored energy to help propel the user forward over the walking surface at a later time in each walking cycle. The actuator motor which applies torque to the ankle joint may be employed to adjust the position of the foot and ankle structure relative to the shin member when the foot and ankle member is not in contact with a support surface. Inertial sensing means may be employed to determine the relative elevation of the foot and ankle structure and to actuate the motor in response to changes in the

relative elevation, thereby automatically positioning the foot member for toe first engagement if the wearer is descending stairs.

#### [0136] Mechanical Design

[0137] The exoskeleton is designed to provide a parallel load path that transfers the weight of the backpack or wearer directly to the ground. The exoskeleton has sufficient degrees of freedom to minimize kinematic constraints experienced by the wearer. The system is designed so that the distal mass of the exoskeleton is minimized. Hip actuation in the sagittal plane is designed so as to minimize the interaction forces between the exoskeleton and the wearer.

#### [0138] Exoskeleton Structure

[0139] The design of an exoskeleton structure must address the fact that the structure's primary function is to support the payload and provide the mechanical interface to the operator so that an assistive propulsive force can be applied to the operator. In essence, the exoskeleton is wrapped around the operator and supports the payload as well as its own load with the objective of minimizing disturbances exerted on the operator. It is also important in exoskeleton design that proximal exoskeleton mass is minimized. A parallel orthotic structure, or the second strategy outlined earlier, is the preferred framework to transfer the load from the backpack to the ground. In the exoskeleton design described herein, the main structural elements consist of standard prosthetic aluminum tubing. This tubing was chosen since it is lightweight, rated for human use, and interfaces with standard prosthetic alignment connectors and components. The criteria for sizing the structural elements must take into consideration not only the stresses, but also the structural stiffness. Thus, minimizing the size and weight of the structural elements must be considered while also maintaining structural stiffness so that the payload can be adequately supported.

[0140] For an exoskeleton to move from the laboratory and be available for practical use it must be adjustable to accommodate a wide range of operator sizes. The goal is to accommodate from the 5% female to the 95% male by adjusting the upper and lower leg segments. Adjustable tube clamps are used to vary the length of the exoskeleton shank and thigh leg segments, and four-screw prosthetic alignment fixtures are used for alignment.

#### [0141] Exoskeleton Degrees of Freedom

[0142] As seen in FIG. 26, the exoskeleton is implemented with three degrees of freedom at the hip, one at the knee, two at the ankle and one at the foot. The joint ranges of motion accommodate normal human walking. A cam mechanism is implemented at the hip joint to enable hip abduction/adduction.

[0143] The exoskeleton hip joint can accommodate the hip's three degrees of freedom which are (1) flexion/extension, (2) abduction/adduction, and (3) medial/lateral rotation. As seen in FIG. 27, revolute joint and Ignus bearings allow hip and medial/lateral rotation. Medial/lateral rotation is realized by means of a ½" I.D. Igus GFI-080906 plain bearing located above the exoskeleton knee.

[0144] As seen in FIG. 28, flexion/extension degree of freedom is realized by means of a 2" I.D. Kaydon JA020XP0 reali-slim ball bearing which permits hip flexion/extension.

**[0145]** Cam Mechanism

**[0146]** During abduction in the coronal plane, there is a length difference between the biological leg and the exoskeleton leg that results from dissimilar centers of rotation between the biological leg and the exoskeleton leg. This effect can impede normal walking motion and cause discomfort. The cam mechanism is designed to automatically adjust the exoskeleton leg length and project the center of rotation of the exoskeleton leg onto the biological hip center of rotation as seen in FIG. 29.

**[0147]** A cam-roller mechanism is designed to mitigate the change in leg length during abduction and still transmit the payload forces to the ground. The exoskeleton leg **3000** couples to the harness by means of a slotted cam located on the side of the hip as seen in FIG. 30. As the biological leg abducts, a roller **3001**, mechanically grounded to the exoskeleton leg, follows the contour of the cam and the exoskeleton leg shortens and tracks the cam profile. The higher the roller **3001** moves up the slotted cam **3002**, the more the exoskeleton leg shortens. The mechanism has one degree of freedom, so that for a given leg abduction angle there is a unique leg length. The profile of the cam is designed by modeling the exoskeleton leg kinematics as a four bar linkage.

**[0148]** The cam is built out of titanium and installed on the exoskeleton. Titanium is chosen because its high degree of hardness lessens the rolling friction of the steel rollers while being lighter than hardened steel. During evaluations, the cam mechanism performed the FIG. 31 further illustrates that the virtual center of rotation of the exoskeleton leg is centered on the human's biological hip center.

**[0149]** Spine and Pelvis

**[0150]** The motions of the legs are coordinated with motions of the spine, shoulders, and arms. Spine, shoulder and arm motions make walking efficient by reducing braking motions transmitted through the legs and pelvis to the upper body. Energy expenditure in walking is increased if the back is immobilized and rotational motions of the pelvis and shoulders are eliminated. This kind of restriction of the motions associated with walking requires a higher metabolic rate for walking. See Carlson, S. (1972) 'How man moves' London: Heinemann

**[0151]** To allow more freedom for the subject during walking, the backpack frame, which was rigidly attached to the hip harness in the exoskeleton, is replaced by a flexible spine seen in FIG. 32. The backpack is supported by the top horizontal shaft of the spine. This shaft joins with a deformable tube that allows the exoskeleton spine to align with the arch of the subject's spine. A coupler joins the deformable tube to a flexible shaft. The coupler contains a V-groove in order to adapt to various shafts of different diameters and stiffnesses. The flexible shaft fits into a yaw coupler that rotates freely about the vertical axis. A second horizontal shaft clamps onto the yaw coupler.

**[0152]** The human pelvis rotates from -10 to +10 degrees during normal walking. The yaw joint at the base of the spine of the exoskeleton that is connected to the pelvic harness allows the spine (and the backpack that is attached to it) to rotate as the human pelvis rotates. In addition to this movement, the flexible shaft bends during walking to allow for pelvic obliquity and tilt. By minimally constraining

normal human movement, we can minimize any negative metabolic effect the exoskeleton may have on the wearer.

**[0153]** Exoskeleton Interface to Human

**[0154]** The exoskeleton interfaces to the human via shoulder straps, a waist belt, thigh cuffs, and a shoe connection. A compliant belt interfaces the lower torso to the backpack frame, and the backpack's shoulder straps interface the upper torso. The physical connection between the exoskeleton and the human enables the exoskeleton to passively track the human's leg motion. A standard military issued backpack, Alice Pack, is selected to carry the load. The exoskeleton is attached to the standard military backpack through a harness. The hip joints of the exoskeleton legs are mounted to the harness. There is sufficient clearance between the pelvic harness and the wearer to minimize disturbances to the wearer's gait.

**[0155]** CF Harness

**[0156]** The exoskeleton is attached to the standard military backpack through a harness that interfaces with the hip joint of the exoskeleton. The pelvic harness provides an intimate fit between the human and the exoskeleton in the region of the pelvis. The structure is made from carbon fiber and is attached to the backpack in a way that maximizes stiffness of the structure.

**[0157]** The harness connects rigidly to the backpack frame to transfer the load from the backpack to the exoskeleton. The pelvic harness is made from carbon fiber and the stiffness to weight ratio is optimized using finite element analysis. The structure consists of a hollow core with  $\frac{1}{16}$ th inch thickness of carbon fiber layer over it. A box is also incorporated into the harness for electronic part storage while at the same time providing structural integrity. FIG. 33 shows the finite element results for the model of the carbon fiber harness. The structure consists of a hollow core with  $\frac{1}{16}$ th inch thickness of carbon fiber layer over it. FIG. 34 shows the final, constructed part. is shown.

**[0158]** Thigh Brace

**[0159]** In order for a passive system to track the knee, a body-exoskeleton attachment above and below the knee is required. A thigh cuff seen in FIG. 35 at **3501** is used to help the exoskeleton track the kinematic motion of the human leg. The cuff is padded and Velcro is used to tighten the fit. A spring steel plate **3503** is installed between the exoskeleton leg and the thigh cuff. The steel plate is compliant in the coronal plane to adjust to the leg contours of different participants, but it is rigid in the sagittal plane to allow for good tracking during walking. A spacer **3505** is inserted to angle the thigh cuff inward for a better fit.

**[0160]** Foot Attach

**[0161]** One approach that may be employed to attach the human foot to the exoskeleton is to attach an exoskeleton foot to the human foot with a piece of elastic, leaf spring material such as spring steel seen at **3601** in FIG. 36. The exoskeleton shank **3603** attaches to a carbon fiber foot **3606** at a non-colocated ankle joint **3608**. The connection is sufficiently rigid so as to keep the exoskeleton foot in line with the human foot and also to allow enough movement between the exoskeleton foot and the human foot in order to minimize discomfort in walking.

[0162] The design allows the payload of the exoskeleton to be transferred to the ground, but it significantly increases the foot print of the wearer plus exoskeleton and thus increases mediolateral center of mass oscillations in walking. A resolution to this difficulty is to integrate the exoskeleton seamlessly into a standard boot or shoe.

[0163] As a resolution to this difficulty, the exoskeleton ankle-foot joint can be integrated into a boot or shoe as is shown in FIG. 37. This design improves on the above design in that it allows the exoskeleton and human ankle joints to be collocated. Further, the exoskeleton foot is integrated into a standard military boot to greatly reduce the foot print compared to the design shown in FIG. 36. The foot print now is the same as the footprint of a standard military boot. In addition to a smaller foot print, the boot has a tuned carbon composite leaf spring at 3701. This spring acts to store energy on heel strike that is later released to help the human heel lift from the ground surface. Another benefit of the heel spring is that it adds improved shock absorption on heel strike and this minimize shock loads on the human joints. A carbon fiber plate 3703 is used to mount the exoskeleton ankle.

#### [0164] Hip Extension Spring

[0165] FIGS. 43 and 44 show the manner in which a hip spring inside a spring holder 4301 and a clear finger guard 4303 is compressed by a plunger 4306 that bears against a Delrin plate and retaining ring at 4308. The spring stores energy during late hip extension, and then that stored energy is released to augment rapid hip flexion as the leg lifts from the ground surface.

[0166] Motivated by the energy management analysis, a uni-directional hip spring is implemented at the hip joint. The LHC-187R-4-M compression spring from Lee Spring is selected since it has a spring constant of 99 lb/in with 2" travel and a 4" free length. Using this particular spring stiffness, the hip muscular work performed is minimized during late hip extension and early hip flexion (lift-off of leg from ground surface). The plunger can be adjusted to a variety of engagement angles. A clear plastic finger guard is also installed for safety.

[0167] The exoskeleton wearer cannot stand upright since the backpack load is offset behind the human and creates an overturning moment that could cause the human to fall backwards as shown in FIG. 45. To counter this moment, the human user can lean forward so that the center of gravity of their upper body is placed over their feet. However, because of the hip extension spring, the human can stand upright. The hip flexion spring creates a counter moment which offsets the overturning backpack moment.

#### [0168] Hip Abduction/Adduction Spring

[0169] When the exoskeleton wearer stands on one leg, a moment is created by the backpack load since it is off center from the biological hip joint. The backpack load and the reaction force from the exoskeleton leg cause a moment about the biological hip center. This moment is undesirable and can cause discomfort. A 250 kN/m abduction spring is implemented to the hip joint to help counter the backpack moment. The spring is unidirectional, and is compressed as the exoskeleton leg undergoes adduction from a vertical orientation. The spring releases its stored energy to promote

hip abduction from a maximally adducted state during level ground walking. The design is shown in FIG. 46.

[0170] During slow human walking, the knee behaves largely as a variable damper where minimal positive power is exerted. The knee of the exoskeleton is implemented with a magnetorheological damper with the fluid in the shear mode. The damper at the knee can exert a maximum braking torque of 60 Nm and consumes on average approximately 1 W of electrical power during level ground walking.

[0171] Knee Control is implemented as a virtual damper with applied current proportional to velocity. FIG. 47 shows the variable damper knee of the exoskeleton.

#### [0172] Spring at the Ankle

[0173] For slow walking, it has been shown that the ankle behaves like a spring where ankle torque correlates with ankle position. For the exoskeleton, a spring located at the ankle joint is designed to store elastic energy during controlled dorsiflexion. This energy is subsequently released to assist the exoskeleton foot in plantar flexion as the foot comes off the ground. FIG. 46 shows the relationship between knee current and knee braking torque.

#### [0174] Exoskeleton Ankle Design for Exoskeleton Foot in Parallel with Human Foot

[0175] One method of implementing a rotary ankle spring is by having a lever compress a linear urethane spring. FIG. 49 and FIG. 36 (discussed above) depict the concept. One could also add another spring on the other side of the lever to store energy in controlled plantar flexion.

#### [0176] Exoskeleton Ankle Design for Foot Integrated into Boot or Shoe

[0177] The exoskeleton ankle design shown in FIG. 50 attaches to the carbon fiber mounting plate shown earlier in FIG. 37. In the previous exoskeleton foot design, shown in FIG. 36, an elastomeric bumper spring is placed at the ankle to store energy during controlled dorsiflexion and then to release that energy to assist powered plantar flexion. The ankle design shown in FIG. 50 works in a similar manner, except that two springs are used instead of one (one for controlled plantar flexion and one for dorsiflexion). Both springs are placed in the green spring holder shown in FIG. 50. The lightweight rod compresses the appropriate spring during the stance period of a walking cycle.

[0178] A second approach for a bi-directional spring design is shown in FIG. 51. Here a carbon composite ankle-foot structure is positioned on the lateral side of the human foot. During a walking stance period, energy is stored in a heel spring during controlled plantar flexion, and then an ankle leaf spring stores energy during controlled dorsiflexion. Finally, these stored energies are released to augment powered plantar flexion.

#### [0179] Bi-Articular Mechanism

[0180] With an actuator at the hip of the exoskeleton, it is possible to transfer that energy down to the ankle via a bi-articular mechanism. An external, bi-articular transfemoral prosthesis, robotic limb, or orthotic brace is shown in a heel strike to toe-off walking sequence. The system comprises above-knee segment (a), knee joint (b), ankle joint (c), posterior knee pivot (d), posterior clutch (e), posterior spring (f), posterior cord (g), knee-ankle transfer clutch (h), anterior

pivot (i), anterior clutch (j), anterior spring (k), and anterior cord (l). As seen in FIG. 52, the system of springs and clutches (or variable-dampers) allows for normal knee and ankle motions throughout the stance period of walking, including early stance knee flexion (1 to 3) and ankle controlled plantar-flexion (1 to 2), controlled dorsi-flexion (2 to 5) and powered plantar flexion (5 to 7). For posterior and anterior clutches (e, j), and knee-ankle transfer clutch (h), the clutch state is designated by an open or closed symbol. Closed symbols represent an engaged or locked clutch state, while open symbols represent a disengaged or unlocked state. For example, during late stance knee flexion (sequence 6 to 7), anterior clutch (j) is in the disengaged state and therefore is designated by with an open symbol. For this combination of series-elastic, variable-clutch or damping mechanisms, hip extension work causes the knee to extend and to elongate an artificial Achilles tendon spring (spring f) and then that stored energy augments powered planter flexion.

[0181] If a clutch is implemented as a variable-damper, a sufficient amount of damping is applied such that the series spring is adequately engaged. A distinct advantage of the variable damper implementation compared with a binary locking or unlocking mechanism, is that energy can be dissipated from the spring if that energy is deemed unnecessary. For example, if energy is stored during a walking step but a leg prosthesis user wishes to stop walking, energy stored in the spring can be dissipated as heat via the series variable damper.

#### [0182] Controller Implementation

[0183] The above-noted U.S. patent application Ser. No. 11/499,853 entitled "Biomimetic motion and balance controllers for use in prosthetics, orthotics and robotics" filed on Aug. 4, 2006, the disclosure of which is incorporated herein by references, describes four different embodiments of motion controllers which operate in real time. These motion controllers are provide postural stability by employing biomechanically inspired optimization strategies in which joint angle trajectories are varied to achieve whole-body postural balance. The above-noted application Ser. No. 11/499,853 presents several embodiments of biomimetic motion and balance controllers which may be used to provide postural balance to an exoskeleton during walking.

[0184] As described below, the exoskeleton may be controlled by reading various sensor values into a central computer mounted on the exoskeleton. Based on these sensor values the appropriate actuation is applied at the hip series elastic actuator and knee variable-damper. This section outlines the electronics hardware used on the exoskeleton as well as the control strategies at the hip and knee joints.

#### [0185] Electronics Test Bed

[0186] The exoskeleton is made autonomous by means of an onboard computer with a data acquisition card, power supply and motor amplifiers. The system is powered by a 48V battery pack. Custom signal conditioning boards amplify sensor readings and provide a differential input to the data acquisition board in order to minimize common mode noise from pick-up in the system. A custom breakout board is designed that interfaces the sensors to the D/A board on the PC 104 as well as providing power to the signal

conditioning boards. The amplifiers for the actuator and brake are 48V digital amplifiers from Copley.

[0187] FIG. 53 is a schematic of the electronic components. The system consists of two actuators at the hips and two variable-dampers at the knees but only one of each is shown here for clarity.

#### [0188] PC 104 and Data Acquisition

[0189] The PC used is a MICROSPACE PC/104 from Digital Logic. It is a miniature modular device that incorporates most of the major elements of a PC compatible computer in a small form factor. It is powered with a PENTIUM III 700 MHz processor. A PC/104 format data acquisition board, Diamond-MM-32-AT, from Diamond Systems is connected to the PC/104. It has 32 total analog inputs and 4 analog outputs. The board is configured for 16 differential analog inputs in software and on the board with jumpers.

[0190] Matlab xPC Target is used to run the code for real-time control and data acquisition. The Matlab xPC real-time kernel is installed and run on the PC/104 (remote PC) which is attached to the exoskeleton. A desktop or laptop computer is then used to create a model in Simulink. xPC Target lets you add I/O blocks to your model and then use the host PC with Real-Time Workshop and a C/C++ compiler to create executable code. The executable code is downloaded from the host PC to the target PC via TCP/IP. After downloading the executable code, one can run and test your target application in real time. Data is recorded by using the xPC host scopes in the simulink model. After running the experiment the host pc is connected to the target pc to download the data.

#### [0191] Actuator Amplifier Boards

[0192] The amplifiers used in the system are general purpose digital servo amplifiers from Copley Controls. They can be used in brushed and brushless mode and offer current, position and velocity control modes (the latter two based on encoder input from the motor to the amplifier). For controlling the series elastic actuators, the Accelus model ASP-090-18 is used. It is rated for a continuous current of 6 Amps and a peak current of 18 Amps. This is chosen based on the fact that the continuous current for the RE40 motor used is 3.33 Amps. The Accelnet Micro Module is used to control the knee brake and is similar to the Accelus but it comes in a PCB mount version which has a much smaller form factor. A custom PCB breakout board is fabricated that interfaces to the Accelnet. The amplifiers are programmed via RS232 using the CME 2™ software from Copley.

[0193] After entering the motor specifications into the software the current loop P and I control gains are determined by using the current loop Auto-Tune feature in the software. The continuous and peak current limits are entered in the software and act as a good safety feature when tuning up the actuators in the early stages. The amplifier control parameters are then saved in flash memory and the RS232 connection can be terminated.

#### [0194] Signal Conditioning

[0195] The sensors on the exoskeleton are read into the computer as analog voltage signals. Due to relatively long connection cables there is a lot of noise pick-up from the amplifiers, motors and brake. In order achieve a good signal



to noise ratio the sensor raw voltage readings are amplified with a differential line driver and the signal is also sent through an analog low pass filter with a cut off at 1.5 kHz.

[0196] Sensing

[0197] The exoskeleton is instrumented with sensors in order to detect state transitions for real time control of actuation at the hip and knee as seen in FIG. 54. The sensors also facilitate analysis of the kinematics and kinetics of gait of the exoskeleton as a function of gait cycle. The angle of the hip (thigh relative to pelvic harness) and the knee (shank relative to the thigh) are measured using rotary potentiometers. Strain gauges on the structure of the exoskeleton shank measure the bending moment of the shank as well as the vertical force borne by exoskeleton leg.

[0198] Angle Sensing

[0199] The angle of the hip (thigh relative to pelvic harness) and the knee (shank relative to the thigh) are measured using rotary potentiometers. The signals from these potentiometers are amplified and filtered using the signal conditioning board in potentiometer configuration with a gain of 1.

[0200] Hip Torque Measurements

[0201] The hip torque produced by the actuator can be measured by means of measuring the deflection of the spring pack of the series elastic actuator. This is the force that is used for the closed loop control of the actuator and by multiplying the force by the moment arm of the actuator the torque at the hip joint can be calculated.

[0202] Ground—Exoskeleton Interaction Sensing

[0203] Strain gauges placed in the structure of the exoskeleton shank are used to measure the bending moment of the shank as well as the vertical force in the exoskeleton leg as illustrated in FIG. 55. The signals from the strain gauges are amplified and filtered using the POT4 board in the strain gauge configuration with a gain of 500. The moment in the shank is calculated by subtracting the signals from the two bridges and the vertical load by adding the two signals.

[0204] Human—Exoskeleton interaction sensing

[0205] For the purpose of measuring the interaction force between the human thigh and exoskeleton leg a custom sensor is built. The sensor consists of a spring pack and the deflection of the springs are measured with a spring loaded linear potentiometer. The device consists of die springs, shown in FIG. 55 that are compressed due to relative movement of the two metal parts (one attached to the exoskeleton leg and the human leg) and the displacement is measured with a linear potentiometer thus giving a reading of the force. This particular design is cheaper and more robust than a load cell.

[0206] One reason for knowing the force at the thigh is that a control strategy could be implemented where by a motor at the hip could servo the exoskeleton to zero the force at the thigh. This would effectively make the exoskeleton get out of the way of the wearer. Another reason for measuring the interaction force at the thigh is to estimate the power transfer between the exoskeleton and the wearer. The velocity at the thigh could be calculated by knowing the velocity of the hip. FIG. 56 shows the thigh cuff sensor for measuring the force between the exoskeleton and the human thigh.

[0207] Control Strategies

[0208] The controller for the exoskeleton is required to perform actuation at the hip and knee based on knowledge of the current phase of gait. A state machine control strategy is implemented based on angle and force sensory readings from the exoskeleton. Human walking kinematic and kinetic data motivated the actuation to be commanded in the individual states. FIG. 57 outlines the desired actuation as a function of gait cycle.

[0209] (1) Hip

[0210] For the Thrust phase, the actuator at the hip exerts a torque to help raise the center of mass of the exoskeleton. During the next phase, Extension Spring, a virtual spring stiffness is programmed that is compressed as the center of mass of the exoskeleton moves forward. As the leg changes direction the Swing Assist phase is entered where the energy is released from the virtual spring, and a torque is applied to assist in swinging the leg forward. Leg Retraction is entered after full hip flexion, and a torque is applied to assist in foot placement and weight acceptance.

[0211] (2) Knee

[0212] Knee On occurs at heel strike, and the damper is programmed to exert a torque proportional to the rotational velocity of the knee joint. Two different gains are used, depending on the velocity sign, to control knee rotation for knee flexion and extension. After the knee is turned off, there is a residual magnetic field and hence a resistive torque. The knee is demagnetized when the knee joint remains locked at full extension during the late stance phase. After this phase, the damper is turned off throughout the entire swing phase.

[0213] Knee Controller

[0214] The state-machine controller for the knee processes knee angle and the force and moment in the exoskeleton leg to define four stages of the walking cycle. FIG. 3.41 shows the states and the triggers used to switch between states. An off state is implemented so that any time the leg is raised off the ground the brake will turn off allowing the knee to bend freely.

[0215] The following table specifies the states and their respective triggers for the state-machine of the knee controller:

State	Description	Trigger
0	Not walking and leg is unloaded	Load in exoskeleton leg
1	Stance Flexion and Extension	Load in exoskeleton leg
2	Pre-swing	Knee angle and moment in exoskeleton leg
3	Swing Flexion	Load in exoskeleton leg
4	Swing Extension	Knee angle

[0216] FIG. 58 is a state machine diagram for the knee controller and shows data collected from the exoskeleton leg as a function of gait cycle. The states of the knee controller are superimposed on the plot of knee angle, load and moment shown at the top, middle and bottom of FIG. 59. FIG. 59 shows the sensor data from the exoskeleton leg for a single gait cycle. States 1 to 4 of the controller are highlighted.

[0217] For steady state walking, the state machine cycles through states 1 to 4. If a person is no longer walking but shuffling or turning around, the controller goes back and forth between state zero, where the leg is off the ground, and state one, where the leg is on the ground.

[0218] FIG. 60 shows the state machine for the exoskeleton knee in operation. The data shows a person walking normally, then shuffling as he turns around, and then walking once again.

#### [0219] Hip Controller

[0220] The state-machine controller for the hip uses the hip angle and the force in the exoskeleton leg to define five stages of the walking cycle. FIG. 61 illustrates these states as well as the triggers used to switch between states. State 1 is late stance extension as this is deemed to be the most repeatable trigger to determine if the wearer has started walking.

[0221] The following table specifies the states and their respective triggers for the hip controller:

State	Description	Trigger
0	Not Walking	Timeout
1	Late Stance Extension	Negative velocity when angle is less than zero
2	Early Swing Flexion	Change in sign of velocity
3	Late Swing Flexion	Angle is greater than some threshold
4	Leg Retraction	Change in sign of velocity
5	Early Stance Extension	Force threshold in leg

[0222] FIG. 61 shows the operation of the state machine controller for the hip. The states in the table above are connected and the causality between states is shown as well as the triggers between states.

[0223] FIG. 3.45 shows data collected from the exoskeleton leg as a function of gait cycle. The states of the hip controller are superimposed on the plot.

[0224] FIG. 63 shows the state machine controller for the hip in operation as a person walks and then stops and shuffles as he turns around and then begins to walk again.

#### [0225] Exoskeleton for Running and Jumping

[0226] This section describes the architecture of an exoskeleton that assists humans in running and jumping. It consists of a configuration that places leaf springs in parallel with the human legs. A pelvic girdle or harness transfers the weight of the wearer through the exoskeleton to the ground instead of those forces being borne by the human's legs.

#### [0227] Mechanical Design

[0228] The designed mechanism creates natural leg stiffness by means of physical springs parallel to the biological leg. The springs store energy and transfer dynamic loads to the ground and effectively lessen the energy consumption of the biological leg and reduce the metabolic cost of jumping and forward running. One implementation of the mechanism is shown in FIG. 64, which uses leaf springs parallel to the leg. The most proximal and distal aspects of the leaf springs are mounted between the hip and ankle joints, respectively.

The damper/clutch device is located in the vicinity of the knee, but not necessarily mounted on the biological knee.

[0229] In FIG. 64, on the left, the foot is shown on the ground with the clutch or variable damper locking the knee joint and the leg spring fully engaged. In contrast, on the right the foot is shown off the ground. Here the biological leg is free to flex and extend the knee as the clutch or variable damper outputs minimal resistance.

[0230] FIG. 65 shows a solid model of the exoskeleton leaf spring mechanism. The distal aspect of the structure can be mounted above the ankle joint, or to the forefoot region.

#### [0231] Leaf Spring Material

[0232] Unidirectional fiber glass barstock, product GC-67-UB, from Gordon Composites, Montrose, Colo. is used as the leaf spring material. A 1.25" width and 0.300" thick spring can support the wearer's weight if his legs go limp, in the sense that the wearer's center of gravity could be suspended about halfway to the ground from its original rest position. Another material that could be used for the leaf spring is carbon fiber composite.

#### [0233] Prototype Exoskeleton

[0234] FIG. 66 shows the prototype exoskeleton being worn by a human test subject.

#### [0235] Controller Implementation

[0236] Force and/or contact sensors are placed under the human foot to detect when the subject's foot is on the ground. A small battery triggers an electromagnet in the clutch that causes the knee to lock or unlock.

[0237] While the subject's foot is in contact with the ground during level ground jumping and running, the clutch will lock uni-directionally, allowing knee extension but not knee flexion. This uni-directional control allows the leaf spring to store/release mechanical energy, but still allows the leg to increase in length (knee extension). The ability to extend the knee is important when the leg is shorter in length at first ground contact compared with the leg length when the leg leaves the ground surface. For level ground motion tasks, the damper/clutch device has two fundamental states. These states are:

[0238] Table 3.3: Clutch States vs. Foot Contact for Level Ground Activities.

[0239] For slope descent, the damping response when the leg is in contact with the ground would be relatively lower for knee flexion so that elastic strain energy is not stored in the leaf springs but rather is dissipated as heat via the variable-damper knees.

[0240] It is noted here that instead of employing a clutch or variable-damper at the exoskeleton knee, a passive, weight-activated knee unit could be used. Here the knee automatically locks upon knee compression loading and unlocks when compression forces are no longer borne by the knee unit. Such weight activated knee units have been useful in prosthetics and orthotics, and are sold commercially throughout the world.

[0241] Finally, it is noted that the knee design might include additional elements such as a motor that would assist the human leg to flex and extend the human-exoskeleton leg during the swing phase, and to augment knee extension

during stance for stair or slope ascent. In addition, a motor might be placed in parallel with the leg spring that stores additional energy into the leg spring to augment leg extension in jumping or stair/hill ascent.

[0242] Metabolic Testing

[0243] Because the human leg acts like a linear spring in running and jumping, it is predicted that the exoskeleton spring legs would reduce the exertion in the human legs and thus reduce overall metabolic cost. This was verified when a human test subject jumped repeatedly for several minutes in the exoskeleton.

[0244] Experimental Methodology

[0245] An oxygen analyzer from Cosmed™ measured the volume of oxygen consumed per minute. The subject wore a mask that captured and analyzed the exhaled oxygen and the resulting data were transmitted wirelessly and saved on a computer.

[0246] To ensure reliability of test results, the room air, turbine, delay, and reference gas calibrations were performed on the oxygen analyzer. In addition, the subject refrained from smoking, caffeine, intense or prolonged exercise within the previous 24 hours before testing, and did not eat within 3 hours of the test but was well hydrated.

[0247] The subject jumped with the exoskeleton at a self-selected height and at a self-selected frequency. To maintain constant jumping frequency, a lab assistant counted the number of jumps in 10 seconds, calculated the average interval between jumps, and programmed this interval into a metronome which sounded beeps to signify when to jump. To regulate jumping height, a lab assistant marked the height of the subject's head at the peak of the jump on a whiteboard behind the subject's head. For the entire test, the lab assistant then informed the subject whether to increase or decrease his jumping height. These experimental steps were repeated for two different jumping heights: 4 inches and 8 inches.

[0248] Each jumping test was followed by a resting test where the subject sat for approximately 8 minutes. During the 8 minute time interval, the oxygen analyzer measured the resting metabolic rate.

[0249] Results

[0250] The subject jumped in the exoskeleton at a self-selected frequency to a height of 4 in while the metabolic rate was recorded via an oxygen analyzer. The subject's oxygen consumption leveled off at about 1500 ml/min. The exoskeleton was doffed and the subject repeated the test by jumping at the same frequency and to the same height, and the oxygen consumption level off to about 2050 ml/min. Each jumping test was followed by a resting period of at least 8 minutes, which had oxygen consumption levels around 300 ml/min.

[0251] The same jumping tests were repeated for a height of 8 in at a frequency that was self-selected for that height. The subject was able to jump continuously for 5 minutes with the exoskeleton, but when it was doffed, the subject could not finish the test due to exhaustion and muscle fatigue. This indicates that the exoskeleton can significantly augment human endurance for spring-like leg operations such as jumping and running.

[0252] Actuation

[0253] This section describes the actuation options at the hip, knee and ankle. Here the term actuation is used to describe the technological strategy employed to generate joint torque, whether the source is spring, variable damper or motor.

[0254] Series Elastic Actuator Design

[0255] Series elastic actuators (SEA) illustrated in FIGS. 38 and 39 were chosen as they provide a means for implementing lightweight and inexpensive force control with a bandwidth similar to that of natural muscle. The SEA has a spring 3901 in series with the output of the motor 3902. The spring acts as a sensor, filter and impedance limiter. The ball screw nut is coupled to the output through four die compression springs in the assembly 3901 and the spring compression is measured with a linear potentiometer. Aluminum guide rods 3904 extend alongside the screw 3906. The motor pulley at 3910 is coupled to the screw bh a 2:1 belt reduction. The motor 3902 and the spring assembly are attached to an attachment yoke 3915 which attaches to the bearing mount on the harness.

[0256] Based on the human walking data described earlier, a 100 to 150 Watt Motor is sufficient to augment hip flexion-extension movements during level ground ambulation. A Maxon RE40 Brushed motor DC motor at 3902 is selected for its power to weight ratio. The ball screw and nut is from Nook Industries. The springs are die Springs from Century Spring. In designing the actuator the moment arm on the hip joint and the force output from the actuator must be calculated.

[0257] Actuator Characterization

[0258] When the actuator as seen in FIG. 39 is used at the hip of the exoskeleton, it experiences two boundary conditions. The actuator may be either directly in contact with the environment or it may be connected to a freely moving inertial load. These boundary conditions represent the stance and swing phase of the walking cycle, respectively. During the stance phase, the load position can be considered a fixed position source, and in the swing phase, the load position is defined as a function of the force in the spring and the load mass. These boundary conditions are characterized separately in order to determine the performance of the actuator for each case.

[0259] Closed Loop Characterization and Force Control

[0260] The closed loop control of the SEA can be obtained from Robinson (2000). For the fixed end condition this represents the stance phase of the walking cycle. The actuator can be controlled with a pure proportional controller alone. This works well for the free end condition but does not work well for the case where the end is fixed. With pure P control if the system hits a hard boundary it will bounce back due to the large impact force borne by the sensor (spring) and the resulting large error signal with opposite sign. However, for a controllable actuator, we desire the actuator to remain at the point where a collision occurs. For this a lead-compensator is used that damps out the movement. A disadvantage of this is that the performance of the free movement of the actuator is degraded. The P and D gains can only be increased so far before the noise in the sensor signal is amplified.

[0261] A resolution to this difficulty is to have a PD controller where the D term is a band limited differentiator. This is the controller that is shown below in a bode plot of the controller. In order to determine the closed-loop bandwidth of the actuator, the end of the actuator is fixed, and a sine wave chirp in force is applied from 1 Hz to 100 Hz. FIG. 40 shows both the experimental and theoretical closed loop bode plots. Experimentally the -3 dB point is found to be at 226/rad/s (36 Hz).

[0262] The proportional P, and derivative D, gains of the controller are tuned experimentally based upon the step response of the actuator and the ability of the actuator to track a sine wave in force.

[0263] Closed Loop Performance with Load Mass

[0264] The actuator will have to apply a torque to the human and exoskeleton leg during the swing phase of the walking cycle. As a result, a test is completed in order to determine the closed loop bandwidth for the case of apply a force to a load mass in space. Shown in FIG. 41 is the experimental and theoretical closed loop bode plot of the actuator with the load mass end condition. The -3 dB point for the experimental curve is 253 rad/s (40.3 Hz) and the theoretical model is 230 rad/s (36 Hz).

[0265] It is shown that the case of applying a force to a mass in space is similar to the case of the fixed end condition. As a result, the controller that is experimentally tuned for the case when the end condition is fixed should work well for the case when moving a load mass. In order to validate this theory a number of simple tests can be performed. FIG. 41 is a plot showing the actuator tracking a hip torque of 100 Nm at a frequency of 5 Hz with an equivalent mass to that of the human and exoskeleton leg.

[0266] In order to determine if the actuator has sufficient force and power capability to power the human and exoskeleton, a test is performed where the actuator is commanded to track a trajectory similar to the human hip trajectory in walking. The test is performed on the bench with an equivalent mass on the end of the arm. FIG. 42 shows closed loop position control testing wherein the actuator is commanded to track a trajectory similar to that of the human hip joint in walking.

CONCLUSION

[0267] It is to be understood that the methods and apparatus which have been described above are merely illustrative applications of the principles of the invention. Numerous modifications may be made by those skilled in the art without departing from the true spirit and scope of the invention.

What is claimed is:

1. An exoskeleton worn by a human user comprising, in combination,
  - a rigid pelvic harness worn about the waist of the user,
  - first and second exoskeleton leg structures each of which extends downwardly alongside one of the human user's legs and each of which comprises:
    - a hip joint for attaching said leg structure at its upper end to said pelvic harness,
    - a knee joint,
    - a thigh member that extends from said hip joint to said knee joint, said thigh member being attached to the human user's thigh,
    - a foot member attached to a shoe worn by said human user,
    - a shin member extending from said knee joint to said foot member, said shin member being attached to said foot member by an ankle joint,
    - a passive spring or an active actuator positioned at said hip joint for applying a motive force for rotating said thigh member with respect to said pelvic harness to assist in lifting said exoskeleton and said human user with respect to the ground surface upon which the user is walking and to propel the exoskeleton and human user forward,
    - a controllable damper operatively connected to said knee joint for arresting the movement relative movement of said shin member and said thigh member at controllable times, and
    - a spring located is said foot member or said ankle joint for storing and releasing energy during walking.
2. An exoskeleton as set forth in claim 1 wherein said pelvic harness is attached to a load-carrying backpack worn on the back of said human user, said backpack being supported on said ground surface by said exoskeleton leg structures.
3. An exoskeleton as set forth in claim 1 wherein said rigid pelvic harness is attached to a seat which supports the human user so that a significant part of the weight of the human user is born by said exoskeleton leg structures.
4. An exoskeleton as set forth in claim 1 wherein the length of said thigh member may be adjusted to accommodate human users of different sizes.
5. An exoskeleton as set forth in claim 1 wherein the length of said shin member may be adjusted to accommodate human users of different sizes.
6. An exoskeleton as set forth in claim 5 wherein the length of said thigh member may be adjusted to accommodate human users of different sizes.

\* \* \* \* \*