

Kinematics analysis, Workspace, Design and Control of 3-RPS and TRIGLIDE medical parallel robots

Dan Verdes[†], Sergiu-Dan Stan[†], *Member, IEEE*, Milos Manic[‡], *Senior Member, IEEE*, Radu Bălan[†], Vistrian Mătieș[†]

[†]Dept. of Mechatronics, Technical University of Cluj-Napoca, Romania, [‡]Dept. of Computer Science, University of Idaho, USA

Abstract — Parallel robots find many applications in human-systems interaction, medical robots, rehabilitation, exoskeletons, to name a few. These applications are characterized by many imperatives, with robust precision and dynamic workspace computation as the two ultimate ones. This paper presents kinematic analysis, workspace, design and control to 3 degrees of freedom (DOF) parallel robots. Parallel robots have received considerable attention from both researchers and manufacturers over the past years because of their potential for high stiffness, low inertia and high speed capability. Therefore, the 3 DOF translation parallel robots provide high potential and good prospects for their practical implementation in human-systems interaction.

Keywords — kinematics, workspace, design, Triglide parallel robot, 3-RPS, 3 degrees of freedom.

I. INTRODUCTION

PARALLEL robots have received considerable attention from both researchers and manufacturers over the past years because of their potential for high stiffness, low inertia and high speed capability. Parallel robots find many applications in human-systems interaction, medical robots, rehabilitation, exoskeletons, to name a few. These applications are characterized by many imperatives, with robust precision and dynamic workspace computation as the two ultimate ones.

The paper is organized as follows. The conceptual designs of the medical robots system are proposed in Section II. The kinematics and analysis is carried out in Section III, where the reachable workspace of the robots is generated. Section IV is focused on the virtual reality model of the robot architectures using the Virtual Reality toolbox from MATLAB/Simulink. The control method is presented in Section V. Finally, this paper concludes with a discussion of future research considerations in Section VI.

Financial support for this work was supported in part by the CNMP under Grant no. 72197/1.10.2008 PARTENERIATE.

Dr. Sergiu-Dan Stan is with the Technical University of Cluj-Napoca, Dept. of Mechatronics, 103-105, B-dul Muncii, 400641, Cluj-Napoca, Romania (+40-264-401755; e-mail: sergiustan@ieee.org). Email contacts of other authors are: misk@ieee.org, matiesvistrian@yahoo.com, radubalan@yahoo.com and verdes.dan@gmail.com.

II. 3 DOF DEGREE OF FREEDOM PARALLEL ROBOTS

The most important requirements of parallel robots are workspace, accuracy, stiffness, and velocity. In order to be used in parallel robot control system, these requirements need to be mathematically expressed and precisely described.

Choosing the optimal robot dimensions for the best performance is still a challenging task. There are a lot of performance criteria which have to be taken into account and which are pose (position and orientation) dependent. These characteristic functions or performance criteria are crucial in establishing the degree of fulfillment of a parallel robot requirement.

The requirements and developed characteristic functions are in general not constant (isotropic) and depend on the location or pose of the mobile platform in plane or space.

Isotropic behavior is strongly desired. In isotropic configuration, the Jacobian matrix has the condition number as well as the determinant equal to one, and the robot performs very well with regards to its force and motion transmission capabilities.

A. Three DOF parallel robots

Parallel robots with 3 degrees-of-freedom are parallel manipulators comprising a fixed base platform and a payload platform linked together by three independent, identical, and open kinematic chains (Fig. 1 & Fig. 2).

The TRIGLIDE parallel robot consists of a spatial parallel structure with three translational degrees of freedom, and is driven by three linear actuators.

The platform is connected with each drive by two links forming a parallelogram, allowing only translational movements of the platform and keeping the platform parallel to the base plane.

An additional rotational axis can be mounted on the working platform to adjust the orientation of the end-effector. The three drives of the structure are star-shaped and arranged in the base plane at 120 degree intervals. Thus, the structure has a workspace which is nearly round or triangle-shaped (Fig. 1).

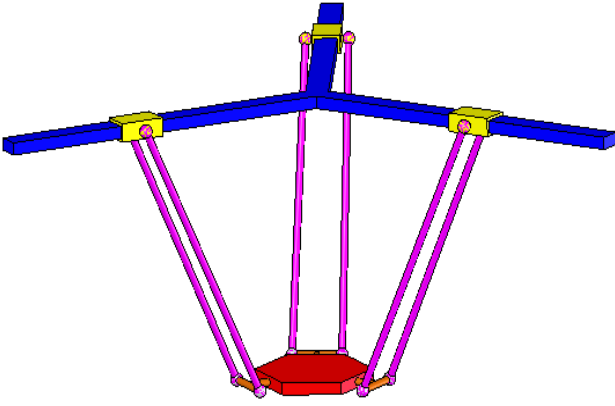

Fig. 1. TRIGLIDE parallel robot with 3 DOF.

The 3-RPS parallel robot with 3 DOF is shown in Fig. 2. Geometric parameters are illustrated by Fig. 3, where the moving platform is connected to the base platform via three identical serial chains.

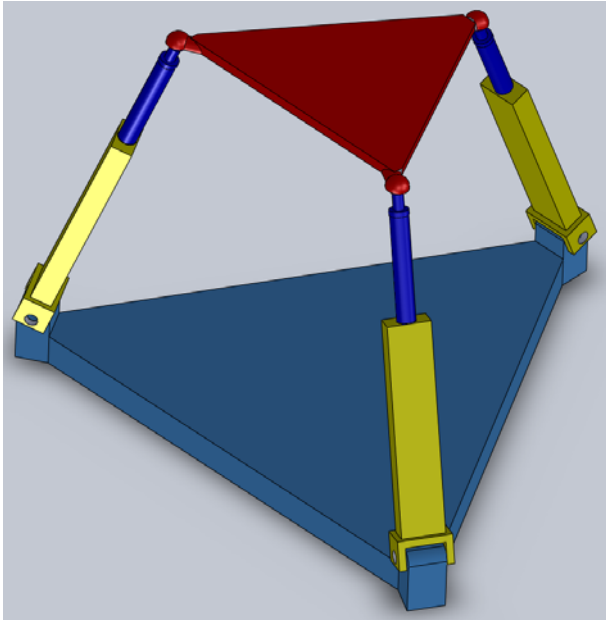

Fig. 2 CAD model of the 3-RPS parallel robot

III. KINEMATICS ANALYSIS OF 3-DOF PARALLEL ROBOTS

Kinematics of the TRIGLIDE parallel robot was extensively presented in [20]. Robot kinematics deals with the study of the robot motion as constrained by the geometry of the links. Typically, the study of the robot kinematics is divided into two parts, inverse kinematics and forward (or direct) kinematics.

The inverse kinematics problem involves a known pose (position and orientation) of the output platform of the robot to a set of input joint variables that will achieve that pose. The forward kinematics problem involves the mapping from a known set of input joint variables to a pose of the moving platform that results from those given inputs.

Fig. 3 shows a spatial parallel robot, 3-DOF, 3-RPS type of parallel robot. It consists of three identical links that connect the moving platform at points B_i by spherical

joints to the fixed base at points A_i , by revolute joints. Each link consists of an upper and a lower member connected by a prismatic joint.

These three prismatic joints are used as inputs for the parallel robot.

Overall, there are eight links, three revolute joints, three prismatic joints and three spherical joints. Thus, the degree of freedom of the parallel robot can be computed with:

$$F = \lambda(n - j - 1) + \sum_i f_i = 6(8 - 9 - 1) + (3 + 3 + 9) = 3 \quad (1)$$

For the kinematic analysis, two Cartesian coordinate systems $A(x, y, z)$ and $B(u, v, w)$ are attached to the fixed base and moving platform, respectively, as shown in Fig. 3.

The following assumptions are made. Points A_1, A_2, A_3 lie on the xy -plane and B_1, B_2 and B_3 lie on the uvw -plane. As shown in Fig. 3, the origin O of the fixed coordinate system is located at the centroid of $\Delta A_1 A_2 A_3$ and the x -axis points in the direction of $\overline{OA_1}$.

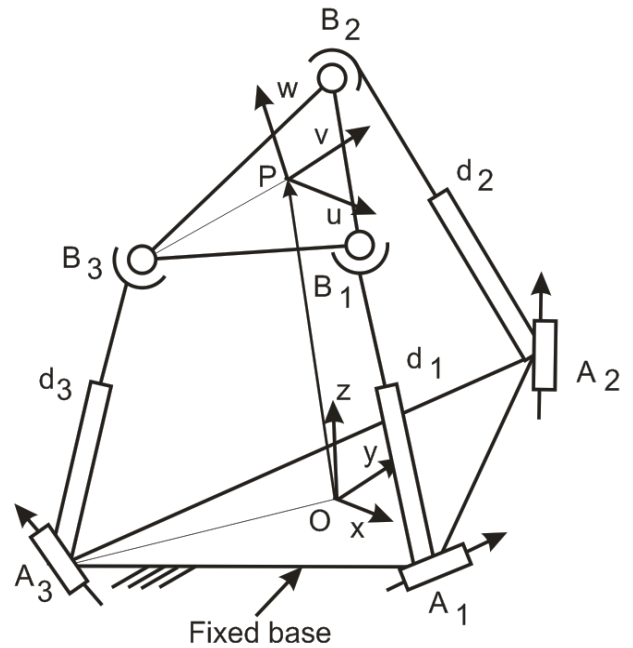

Fig. 3. 3-RPS parallel robot with linear actuators.

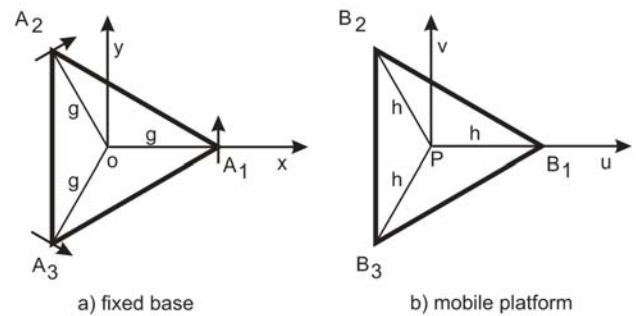

Fig. 4 Top views of the 3-RPS parallel robot

Similarly, the origin P of the moving coordinate system is located at the centroid of $\Delta B_1B_2B_3$ and the u -axis in the direction of $\overline{PB_1}$. Both $\Delta A_1A_2A_3$ and $\Delta B_1B_2B_3$ are equilateral triangles with $|OA_1|=|OA_2|=|OA_3|=g$ and $|PB_1|=|PB_2|=|PB_3|=h$. Furthermore, the axis of each revolute joint, J_i , lies on the x - y plane and is perpendicular to the vector $\overline{OA_i}$.

The transformation from the moving platform to the fixed base can be described by a position vector $p = \overline{OP}$ and a 3×3 rotation matrix ${}^A R_B$.

Let u , v , and w be three unit vectors defined along u , v , and w axes of the moving coordinate system B , respectively; then the rotation matrix can be expressed in terms of the direction cosines of u , v and w as:

$${}^A R_B = \begin{bmatrix} u_x & v_x & w_x \\ u_y & v_y & w_y \\ u_z & v_z & w_z \end{bmatrix}. \quad (2)$$

We note that the elements of ${}^A R_B$ must satisfy the following orthogonal conditions:

$$\begin{aligned} u_x^2 + u_y^2 + u_z^2 &= 1 \\ v_x^2 + v_y^2 + v_z^2 &= 1 \\ w_x^2 + w_y^2 + w_z^2 &= 1 \\ u_x v_x + u_y v_y + u_z v_z &= 0 \\ u_x w_x + u_y w_y + u_z w_z &= 0 \\ v_x w_x + v_y w_y + v_z w_z &= 0 \end{aligned} \quad (3)$$

Let a_i and ${}^B b_i$ be the position vectors of points A_i and B_i , respectively. Then the coordinates of A_i and B_i are given by:

$$\begin{aligned} a_1 &= [g, 0, 0]^T \\ a_2 &= \left[-\frac{1}{2}g, \frac{\sqrt{3}}{2}g, 0 \right]^T \\ a_3 &= \left[-\frac{1}{2}g, -\frac{\sqrt{3}}{2}g, 0 \right]^T \\ {}^B b_1 &= [h, 0, 0]^T \\ {}^B b_2 &= \left[-\frac{1}{2}h, \frac{\sqrt{3}}{2}h, 0 \right]^T \\ {}^B b_3 &= \left[-\frac{1}{2}h, -\frac{\sqrt{3}}{2}h, 0 \right]^T \end{aligned} \quad (4)$$

The position vector q_i and B_i with respect to the fixed coordinate system is obtained by the following transformation:

$$q_i = p + {}^A R_B {}^B b_i \quad (5)$$

and

$$q_1 = \begin{bmatrix} px + hu_x \\ py + hu_y \\ pz + hu_z \end{bmatrix}$$

$$q_2 = \begin{bmatrix} px - \frac{1}{2}hu_x + \frac{\sqrt{3}}{2}hv_x \\ py - \frac{1}{2}hu_y + \frac{\sqrt{3}}{2}hv_y \\ pz - \frac{1}{2}hu_z + \frac{\sqrt{3}}{2}hv_z \end{bmatrix} \quad (6)$$

$$q_3 = \begin{bmatrix} px - \frac{1}{2}hu_x - \frac{\sqrt{3}}{2}hv_x \\ py - \frac{1}{2}hu_y - \frac{\sqrt{3}}{2}hv_y \\ pz - \frac{1}{2}hu_z - \frac{\sqrt{3}}{2}hv_z \end{bmatrix}$$

For the implementation and resolution of forward and inverse kinematic problems of a parallel robot, a MATLAB environment was chosen. This is where a user friendly graphical user interface was developed, as well.

A. Workspace evaluation

Calculation of the workspace and its boundaries with perfect precision is crucial, because they influence the dimensional design, the manipulator's positioning in the work environment, and its dexterity to execute tasks.

In this section, the workspace of the proposed robots will be discussed in details. For a robot in the context of industrial application and given parameters, it is very important to analyze the area and the shape of its workspace.

The workspace is limited by several conditions. The prime limitation is the boundary obtained through solving inverse kinematics.

Further, the workspace is limited by the reachable extent of drives and joints, then by the occurrence of singularities, and finally by the link and platform collisions.

The parallel robots TRIGLIDE and 3-RPS realize a wide workspace, as presented in Fig. 5 & 6.

In order to generate a reachable workspace of parallel manipulators, a numerical algorithm was introduced. Analysis, i.e. visualization of the workspace is an important aspect of performance analysis.

For the sake of simplicity, other design specific factors such as the end-effector size, drive volumes have been ignored.

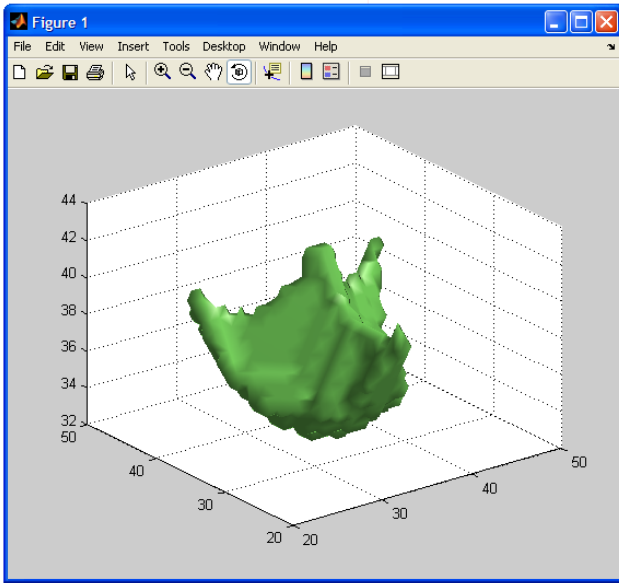

Fig. 5. The workspace for the TRIGLIDE 3 DOF parallel robot.

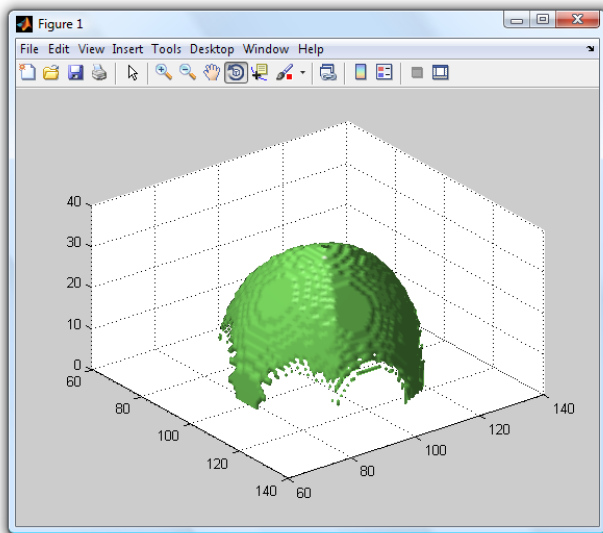

Fig. 6. The workspace for the TRIGLIDE 3 DOF parallel robot.

IV. VIRTUAL REALITY MODEL

The user simply describes the geometric properties of the robot first. Then, in order to move any part of the robot through 3D input devices, the inverse kinematics is automatically calculated in real time.

The interface was also designed to provide the user decision capabilities when problems such as singularities are encountered.

VR interface enables users to interact with the robot in an intuitive way. This means that the operator can pick and choose any part of the robot and move it using translation and rotation using 3D sensors, as easily as a “drag and drop” operation is.

Thus, trajectories can be easily defined, optimized, and stored. Not only that, but the virtual world can be accessed and controlled via the Internet, too.



Fig. 7. TRIGLIDE Virtual Reality model made in Matlab/Simulink

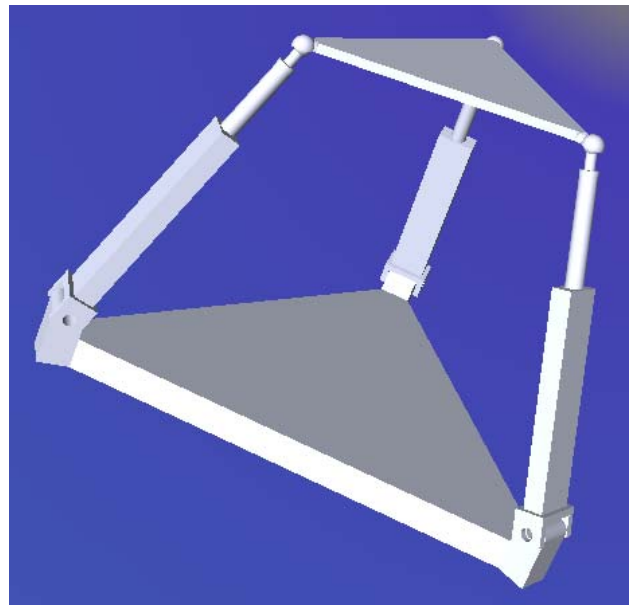

Fig. 8. 3-RPS Virtual Reality model made in Matlab/Simulink

The use of a VR interface to simulate robots drastically improves the “feeling” for the robot.

In particular, the interface allows user to understand the behavior of an existing robot, and to investigate the performance of a newly designed structures without the need and the cost associated with the hardware implementation.

V. CONTROL

In this section discusses the kinematic characteristics of the 3-RPS parallel mechanism. The mechanism has three degrees of freedom, i.e., one translation and two rotations. In them, it is difficult to identify the possible rotational axes by observation, and more difficult to identify the possible continuous rotational axes. The simulation of running the robot was based on the Simulink module from MATLAB.

The control of the robot is implemented using a joint-based control scheme. In such a scheme, the end-effector is positioned by finding the difference between the desired quantities and the actual ones expressed in the joint space [1]. The command of the robot is expressed in Cartesian coordinates of the end-effector.

Using the inverse kinematic problem, these coordinates become displacements. These displacements further become the reference points for the control algorithm. For the control of the robot, one motor element was used for each actuator of a PI control algorithm.

The inputs of the algorithm were the differences between the angles computed (via inverse kinematic problem equations), and the values from sensors. The control signal was applied on three DC motors which were actuating the robot structure.

The controller parameters k_p and k_i were optimized for a given trajectory and a maximum error, using the block Signal Constraint from the Simulink Response Optimization toolbox.

The control of the parallel robot is implemented using a joint-based control scheme. In such a scheme, the end-effector is positioned by finding the difference between the desired extent of movements and the actual one, expressed in the joint space.

The command of the robot is expressed in Cartesian coordinates of the end-effector. Using the inverse kinematic problem, these coordinates become displacements. These displacements will further become the reference points for the control algorithm.

The control scheme of the robot is presented in Fig. 9.

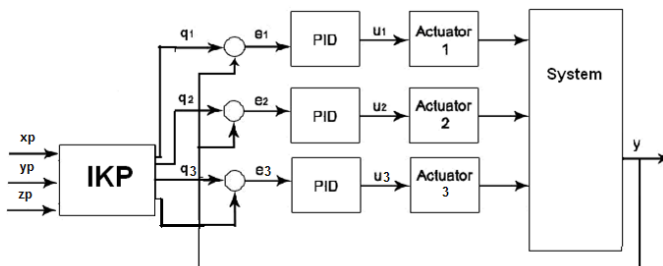

Fig. 9 Control block scheme for 3-RPS parallel robot

MATLAB/Simulink was chosen as a tool that is a widely used for modeling, simulation and testing of dynamical systems. It indicates the rotational axes of the 3-RPS mechanism cannot be chosen arbitrarily in the path planning. Therefore, making sure the continuous rotational axes of 3-RPS manipulator has important significance in control.

A model in Simulink is represented graphically by means of a number of interconnected blocks.

The simplest control strategy, which can be taken into account, is view on the robots-manipulators, powered by group of the independent systems (drives - actuators), controlled separately, as a set of single-input / single-output systems. 3-RPS parallel robot is controlled by means of traditional PID schemes in position/velocity, considering only their kinematics: the reference trajectory of the end-effector is established a priori.

It's planned in the future to apply the use of more sophisticated algorithms, such as *hybrid position-force control (HPFC)* and *impedance control*, which allows fulfilling the requirements of complex and critical tasks, sometimes still performed manually and in general to enhance the performance of the robot.

Simulation

There are several reasons for realizing a model of the platform. Firstly, it is possible to check the functionality of the construction and to determine the working area by simulation. Furthermore, the control program can be developed and tested before the real platform is available.

The mechanical construction is performed with the CAD program SolidWorks [5] and the data is exported to Sim-Mechanics [6], a simulation tool for mechanical systems.

Using SimMechanics the dynamic behavior of the platform can be tested with a real or simulated control before it is set up. The model of the manipulator respects geometrical constraints, joints and mass distribution. Friction is neglected in this model.

In order to simulate the behaviour of the robot, a dynamic model of the robot has to be built. This is a complex subject and different methods were developed in order to solve it.

A classical approach to closed-chain dynamic modeling is to first consider an equivalent tree-structure, and then to consider system constraints via Lagrange multipliers or d'Alembert's principle [2].

Other approaches include the use of virtual work, Lagrange formalism, Hamilton's principle, and Newton-Euler equations.

In this article the dynamic model of the robot is built using the SimMechanics toolbox from Simulink. The toolbox uses the standard Newtonian dynamics of forces and torques in order to solve both the direct and the inverse problem. The model was built from Simulink blocks that represent the kinematic elements and joints of the robot.

These blocks allow modelling of mechanical systems consisting of any number of rigid bodies, connected by joints representing translational and rotational degrees of freedom.

In order to build a SimMechanics model, one has to specify the inertial properties of the body such are degrees of freedom and constraints, along with coordinate systems that is attached to each body of the structure.

This procedure can be very difficult for bodies with complex geometric forms, however, the process can be simplified by use of a SolidWorks tool.

All three kinematic chains are defined by body and joint blocks. The inertia properties and the coordinates of the joints for each body were determined automatically when the CAD model was imported in MATLAB/Simulink environment.

The connection of the mechanical model of the robot to the rest of the robot model was realized via actors and joint blocks. Inputs of the model can be one of the following: the generalized force, the position, speed, or the acceleration of the motor joints. In this paper, the inputs chosen were the speed of all three motor joints of the robot. As outputs, the angles of each motor element were chosen. In addition, sensors were used to determine the position of the end-effector.

VI. CONCLUSION

Parallel robots such in human-systems interaction such as medical, rehabilitation, exoskeleton robots depend on robustness, precision, and dynamic workspace computation, as the ultimate aspects of their safe and successful interaction with humans. This paper presents fundamental guidelines kinematics, design and control of 3 DOF parallel robots.

Future work entails employment of fuzzy intelligent control for addressing dynamic robot movements, and neural network control for dynamic learning of workspace for autonomous robot deployment.

An interactive tool for dynamics system modeling and analysis was presented and exemplified on the control in Virtual Reality environment of the 3 DOF parallel robots. By means of SimMechanics, the authors considered robotic system as a block of functional diagrams. Besides, such software packages allow visualizing the motion of mechanical system in 3D virtual space. Especially non-experts will benefit from the proposed visualization tools, as they facilitate the modeling and the interpretation of results.

ACKNOWLEDGMENT

Financial support for this work was supported in part by the CNMP under Grant no. 72-197/1.10.2008 PARTENERIATE, title of the project ‘Complex mechatronics systems for medical applications’.

REFERENCES

- [1] Gupta, A., et al., “Design, Control and Performance of RiceWrist: A Force Feedback Wrist Exoskeleton for Rehabilitation and Training”, *The Int. J. of Robotics Research*, Vol. 27, No. 2, 233-251 (2008).
- [2] J. P. Merlet. “Determination of the orientation workspace of parallel manipulators”. *Journal of intelligent and robotic systems*, 13:143–160, 1995.
- [3] A. Kumar, KJ. Waldron. “The workspace of mechanical manipulators”. *ASME J. Mech. Des.* 1981; 103:665-672.
- [4] YC. Tsai, AH. Soni. “Accessible region and synthesis of robot arm”. *ASME J. Mech. Des.* 1981, 103: 803-811.
- [5] KG. Gupta, Roth B., “Design considerations for manipulator workspace”. *ASME J. Mech. Des.* 1982, 104(4), 704-711.
- [6] K. Sugimoto, Duffy J, Hunt KH, “Special configurations of spatial mechanisms and robot arms”. *Mech Mach Theory* 1982, 117(2); 119-132.
- [7] KC. Gupta. “On the nature of robot workspaces”, *Int. J. Rob. Res.* 1986; 5(2): 112-121
- [8] JK. Davidson, KH. Hunt, “Rigid body location and robot workspace: some alternative manipulator forms”. *ASME J. Mech. Transmissions Automat Des* 1987, 109(2); 224-232.
- [9] SK. Agrawal, “Workspace boundaries of in-parallel manipulator systems”. *Int. J. Robotics Automat* 1990, 6(3) 281-290.
- [10] C. Gosselin, Angeles J. “Singularities analysis of closed loop kinematic chains”. *IEEE-T.Robotics Automat* 1990; 6(3) 281-290.
- [11] M. Cecarelli, “A synthesis algorithm for three-revolute manipulators by using an algebraic formulation of workspace boundary”. *ASME J. Mech. Des.* 1995; 117(2(A)): 298-302.
- [12] S. K. Agrawal. “Workspace boundaries of in-parallel manipulator systems”. *IEEE Transactions on Robotics and Automation*, 7(2):94–99, 1991.
- [13] F. Pernkopf and M. Husty, ”Reachable Workspace and Manufacturing Errors of Stewart–Gough Manipulators”, *Proc. of MUSME 2005, the Int. Sym. on Multibody Systems and Mechatronics Brazil*, 2005, p. 293-304.
- [14] S. Stan, Diplomarbeit, *Analyse und Optimierung der strukturellen Abmessungen von Werkzeugmaschinen mit Parallelstruktur*, IWF-TU Braunschweig, 2003, Germany.
- [15] K. Cleary and T. Arai. “A prototype parallel manipulator: Kinematics, construction, software, workspace results, and singularity analysis”. In *Proceedings of International Conference on Robotics and Automation*, pages 566–571, Sacramento, California, April 1991.
- [16] C. Ferraresi, G. Montacchini, and M. Sorli. “Workspace and dexterity evaluation of 6 d.o.f. spatial mechanisms”. In *Proceedings of the ninth World Congress on the theory of Machines and Mechanism*, pages 57–61, Milan, August 1995.
- [17] M. Ceccarelli, G. Carbone, E. Ottaviano, “An Optimization Problem Approach For Designing Both Serial And Parallel Manipulators”, *Proc. of MUSME 2005, the Int. Sym. on Multibody Systems and Mechatronics Uberlandia, Brazil*, 6-9 March 2005
- [18] M. Ceccarelli, *Fundamentals of Mechanics of Robotic Manipulation*, Dordrecht, Kluwer/Springer, 2004.
- [19] G. Gogu, “Evolutionary morphology: a structured approach to inventive engineering design”, 5th. International Conference. IDMME 2004, France.
- [20] Stan, S.-D, Manic, M., Mătieș, M., Bălan, R., “Evolutionary Approach to Optimal Design of 3 DOF Translation Exoskeleton and Medical Parallel Robots”, HSI 2008, IEEE Conference on Human System Interaction, Krakow, Poland, May 25-27, 2008.
- [21] Stan, S.-D, Manic, M., Mătieș, M., Bălan, R., “Kinematics Analysis, Design, and Control of an Isoglide3 Parallel Robot (IG3PR)”, IECON 2008, The 34th Annual Conference of the IEEE Industrial Electronics Society, Orlando, USA, November 10-13, 2008.