

Design of an Exoskeleton for Index Finger Rehabilitation

Ju Wang, Jiting Li, Yuru Zhang, Shuang Wang

Abstract—This paper presents a new exoskeleton with 4 degrees of freedom (DOF) for index finger rehabilitation. The device can generate bi-directional movement for all joints of the finger through cable transmission, which is required for passive and active trainings. With two prismatic kinematic joints in the design, it can accommodate to some extent variety of hand sizes. The kinematic relation between the device joint angles and the corresponding finger joint angles is simple which greatly simplifies the high level motion control. As the motor capability of patients may be different and the range of motion of the finger may change along with the rehabilitation progress, it is important to take the changes into consideration. And the preliminary experiment has shown that the proposed device is capable of accommodating to these varieties.

I. INTRODUCTION

As we know, the normal motor capability of hand is crucial and important for human-being's daily life. Hands, however, are apt to be injured in accident. And the rehabilitation is essential for the patients to recover after hand operation. Additionally, diseases, stroke for instance, can also result in the loss of hand function. In order to regain the motor capability, the hand rehabilitation is a fundamental therapeutic approach.

Recent research showed that incorporating mechatronic devices and virtual reality into hand rehabilitative training is feasible and effective [1]. Some hand exoskeletons [2-4] have been developed as the force feedback device. Although for different purpose of application, these haptic devices have many advantages for design of devices for hand rehabilitation. And some exoskeletons have been designed and developed specially for the purpose of hand rehabilitation. One of the instances is a rehabilitation robot worked out in Gifu University. The robot has 18 DOFs and can be driven to actuate impaired hand by the patient's healthy hand on the other side [5]. Another one is a CMP designed in Harbin Institute of Technology [6]. In addition, the exoskeletons designed in Technical University of Berlin [7] [8] and in Northwestern University [9] are typical models. The former can actuate 4 DOFs of a finger by the means of linkage mechanism. And the later is an exoskeleton with 3 DOFs for index finger and can control the joints of index finger respectively.

In this paper, we present a new exoskeleton which can realize functions as follows:

Ju Wang, Jiting Li, Yuru Zhang and Shuang Wang are with the State Key Laboratory of Virtual Reality Technology and Systems, Robotics Institute, Beihang University, Beijing, China. (phone: +86-10-82317750; e-mail: wangju1985@gmail.com, lijiting@buaa.edu.cn, yuru@buaa.edu.cn, wangshuang_110@yahoo.com.cn).

- 1) The ability of bidirectional actuation and controlling each joint respectively;
- 2) Accommodating to some extent variety of hand sizes;
- 3) Changeable range of motion (ROM);
- 4) Integrating sensors to measure the force exerted on finger phalanges.

The next section describes mechanical design of the exoskeleton. And kinematic analysis and function analysis are addressed in the section III. Conclusion of the current work and the future research are discussed in the last section.

II. MECHANICAL DESIGN

A. Kinematics simplification for index finger

The index finger can be modeled as a 4 linkages mechanism with 4 DOFs, as shown in Fig. 1. There are 3 joints on an index finger, which are named as DIP (distal interphalangeal), PIP (proximal interphalangeal), and MCP (metacarpophalangeal) joints. The MCP joint has 2 DOFs which is divided into MCP1 and MCP2, which realize movement of extension/flexion and adduction/abduction respectively. While each of DIP joint and PIP joint has only 1 DOF for extension/flexion. And the average data about index finger we measured in our laboratory are shown in Table I and Table II. These data are measured from healthy people, which can be as the maximum for patients.

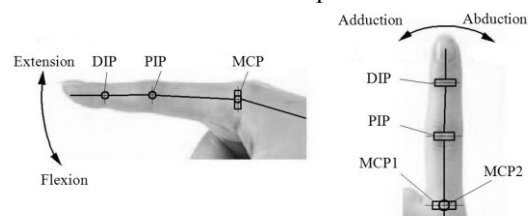

Fig. 1. Biomechanical model of index finger

TABLE I
ROM AND OUTPUT TORQUE OF JOINTS

Joint	DIP	PIP	MCP1	MCP2
ROM (Degree)	0~80	0~100	0~85	0~45
Max torque(Nm)	0.163	0.175	0.315	0.160

TABLE II
LENGTH OF PHALANGES

Phalange	Distal	Middle	Proximal
Length(mm)	25	30	45

B. Scheme Design

To cover the full range of finger motion and prevent interference with other fingers, the exoskeleton is mostly

mounted on the back side of hand. There are some schemes that could be taken into account. The first one is linkage mechanism, which is adopted in [7]. The other scheme is circular link [4] [6]. The parallel joint is the third one, which is adopted in our design. However, there is a problem that it may interfere with finger phalanges when the finger bends [10]. To avoid the problem, we propose a new scheme, which is demonstrated in Fig. 2. The whole system can be divided into two main parts, actuator module and exoskeleton module. We use DIP module to show the principle of motion. Two prismatic joints and a revolute joint are adopted to constitute the parallel joint, which can avoid the problem aforementioned. And cable transmission is used to transmit force and motion. The actuator module drives the sector wheel bi-directionally to realize the flexion and extension of human finger.

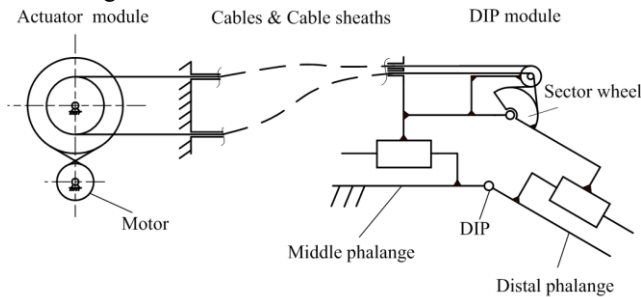

Fig. 2. Layout of the device

C. Exoskeleton Module

As illustrated in Fig. 3, the exoskeleton comprises 4 parts: DIP module, PIP module, MCP1 module and MCP2 module. Each of the modules has 1 DOF, which are totally 4 DOFs for the whole index finger. We take the DIP module for example to describe the detailed design. The bases for distal and middle phalange are fastened respectively on the corresponding distal phalange and middle phalange by straps (not illustrated). The slotted sliders can slide on the base for middle phalange. And the fore slider can slide on the base for distal phalange. The fore slider is connected with the sector wheel by screws. And the sector wheel can rotate on the slotted sliders. So the sector wheel can translate and rotate simultaneously with respect to the bases for distal phalange and middle phalange.

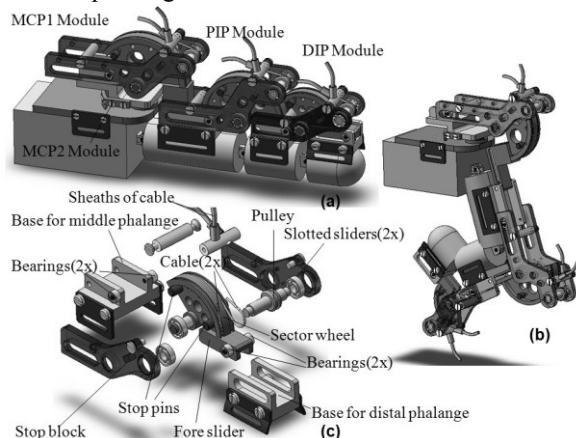

Fig. 3. Drawings of the exoskeleton module (a) Exoskeleton with stretched finger, (b) Exoskeleton with bent finger, (c) Explosive view of DIP module.

Fig. 4 is the detail of prototype of the PIP module. To reduce the friction between the sliding surfaces of the exoskeleton, the material of fore slider and slotted slider is aluminum alloy while that of bases is ABS. To keep it light-weighted, the most parts are aluminum alloy. It is two cables that pull the sector wheel to implement the bidirectional movements. The end of cable 1 is fixed at point A, while that of cable 2 is done at point B. And the pulley is used to change the transmission direction of cable 1. When the cable 1 pulls the sector wheel, the flexion is realized. While when the cable 2 does it, the extension is achieved. Additionally, the method of cable transmission can keep high back-drivability, compared with gear transmission. The weight of the PIP module is about 40 grams. And that of the whole exoskeleton module mounted on the finger is about 120 grams.

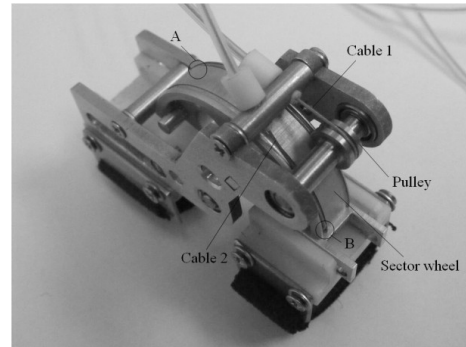

Fig. 4. Detail of Prototype of PIP module

D. Actuation and transmission

In order to minimize the weight added to the patient's finger, the actuator module is placed far away from the exoskeleton. We design 4 actuator modules to drive the exoskeleton. These modules are same, two of which are used to drive MCP1 and MCP2 for 2 DOFs, and the others are done to realize 1 DOF of PIP and DIP respectively. The explosive view of the actuator module is illustrated in Fig. 5.

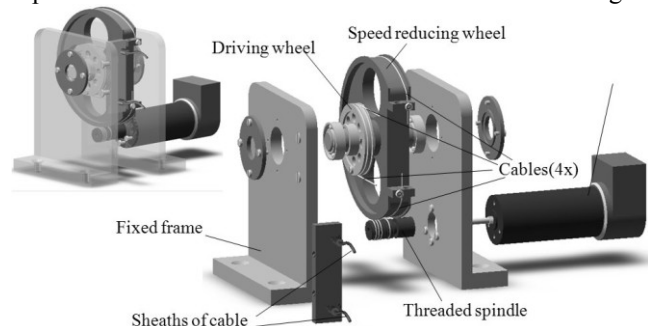

Fig. 5. Explosive view of actuator module for DIP

A DC-motor with encoder is mounted on a fixed frame. The threaded spindle is connected to the motor shaft and transmits torque to the so called speeding reducing wheel through two cables. The transmission ratio is 1:8, which consider the requirement of output torque as well as that of the back-drivability. Each end of the two cables is fastened on the speed reducing wheel and threaded spindle respectively.

Considering the long and changeable distance between the actuator module and the exoskeleton, another two cables are

used to transmit the force from driving wheel to the sector wheel which has been described in section II B. The transmission scheme is shown in Fig. 6. The two cables are named as cable 1 and cable 2. One of ends of each cable is fixed on driving wheel. The others are fastened on sector wheel, as shown in Fig. 3. When the driving wheel rotates at the direction illustrated in Fig. 6. The cable 1 is pulled to drive the sector wheel to realize finger flexion, while the opposite direction can achieve finger extension.

The transmission ratio of driving wheel to sector wheel is 1:1. In order to avoid slackness of the cables between the actuator module and exoskeleton, the cables are coated with sheaths which are made of Teflon for reducing friction [4]. Fig. 7 demonstrates the manufactured prototypes of the actuator module connected with PIP module, which is attached on human finger.

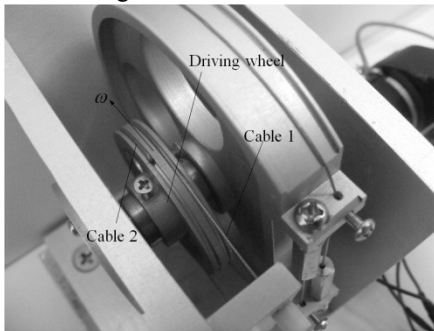

Fig. 6. Cable transmission with two cables

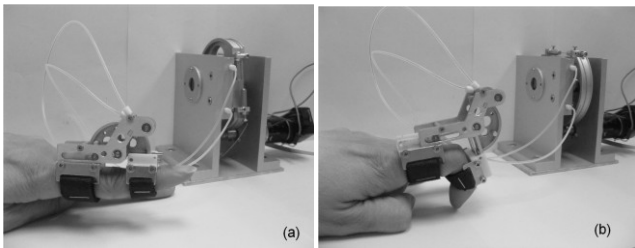

Fig. 7. Prototype of the system

E. Sensors

For the sake of accurate passive and active control of the exoskeleton, force sensor and angular position sensor are needed. In addition, information from sensors can be used to analyze and evaluate the rehabilitative effect. The force sensor is used to record the force exerting on the finger phalanges during the whole rehabilitative process. Considering the advantages of flexion, thin and light, the Flexiforce® sensor is chosen as the force sensor. And two force sensors are attached on each phalange. The angular position sensor is the encoder attached on the DC-motor. The resolution of the sensor is 0.72 degree. Basing on the transmission ratio and the angle measured by encoder, the angle of the joint can be easily calculated.

III. ANALYSIS

A. Kinematic analysis

As illustrated in Fig. 8, the movements of slotted slider and fore slider are always parallel with the phalanges, therefore the angle the sector wheel rotates is equal to that the DIP joint

does. So without complex calculation, it is easy to get the angle of joint. And the relationship between the joint angle and displacements of each slider is as follows:

$$\theta = \arctan\left(\frac{S_1}{d}\right) + \arctan\left(\frac{S_2}{d}\right) \quad (1)$$

Where θ is the angle of a joint; S_1 , S_2 are the displacements of fore slider and slotted slider with respect to the bases fixed on the phalange; d is the distance between the centre line of phalange and axis of the sector wheel.

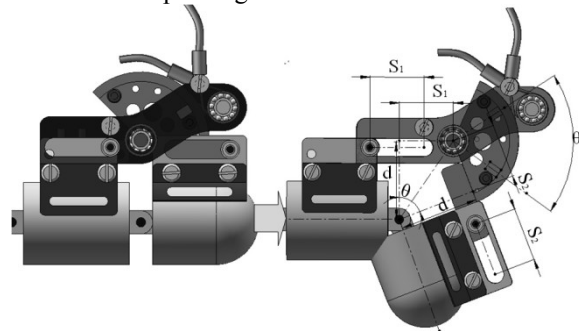

Fig. 8. Bending of DIP joint

According to geometry, it is easily known that S_1 and S_2 in (1) are equal. In addition, taking account of the limitation of the space and intervention of different modules, the displacements of fore slider and slotted slider with respect to the bases fixed on the phalange, S_1 and S_2 are limited. According to (1), the angular scopes of the DIP, PIP and MCP1 joints are $0^\circ \sim 65^\circ$, $0^\circ \sim 80^\circ$ and $0^\circ \sim 73^\circ$, when the exoskeleton is fixed on the hand. And knowing the lengths of each phalange and the angles of each joint mentioned above, we can calculate the workspaces of fingertip with and without exoskeleton, which are indicated in Fig. 9.

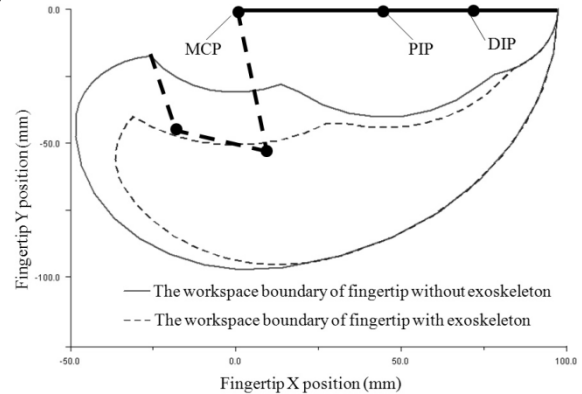

Fig. 9. Workspaces of fingertip with and without exoskeleton

B. Function analysis

For patients, they should experience two rehabilitation phases to regain the motor ability, passive and active training phases (from the aspect of human being). And we know that, from section II, the exoskeleton can realize bi-direction motion through two cables transmission, which provide favorable condition for the passive and active training modes.

The prismatic mechanism can not only realize the motion we require but also accommodate to some extent the variety

of hand sizes. As indicated in Fig. 10, we can adjust the positions of the fore slider and slotted slider with respect to the bases to different lengths of finger phalange.

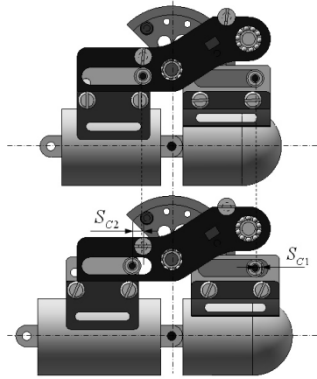

Fig. 10. Accommodating different sizes of finger

Because of the parallel joint, the device joint angles are equal to corresponding finger joint angles. In addition, according to (1), we get the conclusion that the device joint angles are independent upon the positions where the device is on the finger. So it brings great advantages to the high level motion control without taking account of other factors but just the angles of device joints.

In real therapy, different patients have various motor capabilities. Additionally, a patient's range of motion can change during the process of rehabilitation. For the purpose of adapting the change, the finger exoskeleton can adjust its joint angles to the desired range through changing the position of the stop pins relative to the stop block, which meanwhile is the extra security guarantee to patients besides of the software consideration. When we change the position of the stop pins relative to the stop block, as shown in Fig.11 (a) (b), the maximal angle of the joint θ_2 illustrated in Fig.11 (b) is greater than that θ_1 indicated in Fig.11 (d).

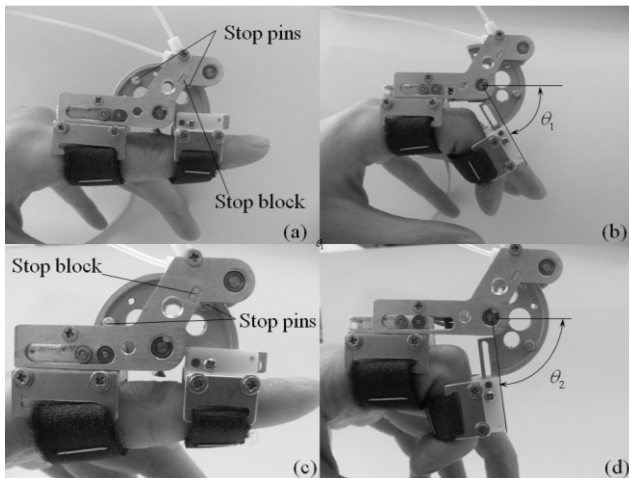

Fig. 11. Changeable range of motion

IV. CONCLUSION AND FUTURE WORK

A new exoskeleton for index finger rehabilitation is proposed in the paper. The device can be driven bi-directionally and control each joint respectively. Apart from that, it has the ability of changing range of motion to

accommodate to different sizes of human hand. And through force and angular position sensors integrated on the exoskeleton, the device can measure the force exerting on the finger and angles of joint during the process of rehabilitation. In addition, because all the fingers of human hand can be modeled as the same model except for the thumb, the scheme designed for index finger rehabilitation can also be adopted for the other 3 fingers.

The current work focuses on the mechanical design and the realization of function. Next step, the dynamic properties and parameters, such as back-drivability, will be quantified. And experimental tests will be carried out to optimize the design. Additionally, we are going to take account of the design of the exoskeleton for thumb which is more difficult than that for other fingers due to the complicated structure.

REFERENCES

- [1] Heidi C. Fischer, Kathy Stubblefield, Tiffany Kline, Xun Luo, Robert V. Kenyon, and Derek G. Kamper, "Hand Rehabilitation Following Stroke: A Pilot Study of Assisted Finger Extension Training in a Virtual Environment," *Topics in Stroke Rehabilitation*, Jan.- Feb. 2007.
- [2] <http://www.immersion.com/>
- [3] Mourad Bouzit, Grigore Burdea, George Popescu, and Rares Boian, "The Rutgers Master II – New Design Force – Feedback Glove," *IEEE/ASME Transactions on Mechatronics*, vol. 7, no. 2, pp. 256-263, June 2002.
- [4] Mark J.Lelieveld, Takashi Maeno, Tetsuo Tomiyama, "Design and Development of Two Concepts for a 4 DOF Portable Haptic Interface With Active and Passive Multi-Point Force Feedback for The Index Finger," *ASME International Design Engineering Technical Conference & Computers and Information in Engineering Conference*, 2006
- [5] Satoshi Ito, Haruhisa Kawasaki, Yasuhiko Ishiguro, "A Design of Fin Motion Assist Equipment For Disabled Hand in Robotic Rehabilitation System," *Proceeding of the First International Conference on Modeling, Simulation and Applied Optimization*, Feb. 2005
- [6] Yili Fu, Peng Wang, Shuguo Wang, Hongshan Liu, Fuxiang Zhang, "Design and development of a portable exoskeleton based CPM machine for rehabilitation of hand injuries," *IEEE International Conference on Robotics and Biomimetics*, pp.1476-1481, Dec. 2007.
- [7] Andreas Wege, Konstantin Kondak, and Günter Hommel, "Mechanical Design and Motion Control of a Hand Exoskeleton for Rehabilitation," *IEEE International Conference on Mechatronics and Automation*, pp. 155-159, 2005
- [8] Andreas Wege, Günter Hommel, "Development and Control of a Hand Exoskeleton for Rehabilitation of Hand Injuries," *IEEE/RSJ International Conference on Intelligent Robots and Systems*, pp. 3046-3051, Aug.2005
- [9] T.T. Worsnopp, M.A. Peshkin, J.E. Colgate, and D.G. Kamper, "An Actuated Finger Exoskeleton for Hand Rehabilitation Following Stroke," *IEEE 10th International Conference on Rehabilitation Robotics*, pp. 896-901, June 2007.
- [10] Shuhei Nakagawara, Hiroyuki Kajimoto, Naoki Kawakami, Susumu Tachi and Ichiro Kawabuchi, "An Encounter-Type Multi-Fingered Master Hand Using Circuitous Joints," *IEEE international Conference on Robotics and Automation*, pp. 2667- 2672, April 2005.